

# SCON

## **SCON-CB Series Controller** **Servo Press Function Instruction Manual** **Fifth Edition**

<b>CB-F</b>	<b>Standard Type</b>
<b>LC-F</b>	<b>PLC Feature Equipped Type</b>
<b>CGB-F</b>	<b>Safety Category Complied Type</b>
<b>LCG-F</b>	<b>Safety Categories Complying PLC Feature Equipped Type</b>



***IAI Corporation***



## Please Read Before Use

Thank you for purchasing our product.

This Instruction Manual describes all necessary information items to operate this product safely such as the operation procedure, structure and maintenance procedure.

Before the operation, read this manual carefully and fully understand it to operate this product safely.

The enclosed DVD in this product package includes the Instruction Manual for this product.

For the operation of this product, print out the necessary sections in the Instruction Manual or display them using the personal computer.

After reading through this manual, keep this Instruction Manual at hand so that the operator of this product can read it whenever necessary.

### [Important]

- This Instruction Manual is original.
- The product cannot be operated in any way unless expressly specified in this Instruction Manual. IAI shall assume no responsibility for the outcome of any operation not specified herein.
- Information contained in this Instruction Manual is subject to change without notice for the purpose of product improvement.
- If you have any question or comment regarding the content of this manual, please contact the IAI sales office near you.
- Using or copying all or part of this Instruction Manual without permission is prohibited.
- The company names, names of products and trademarks of each company shown in the sentences are registered trademarks.



## Construction of Instruction Manual for Each Controller Model and This Manual

### SCON-CB/CGB Servo Press Type

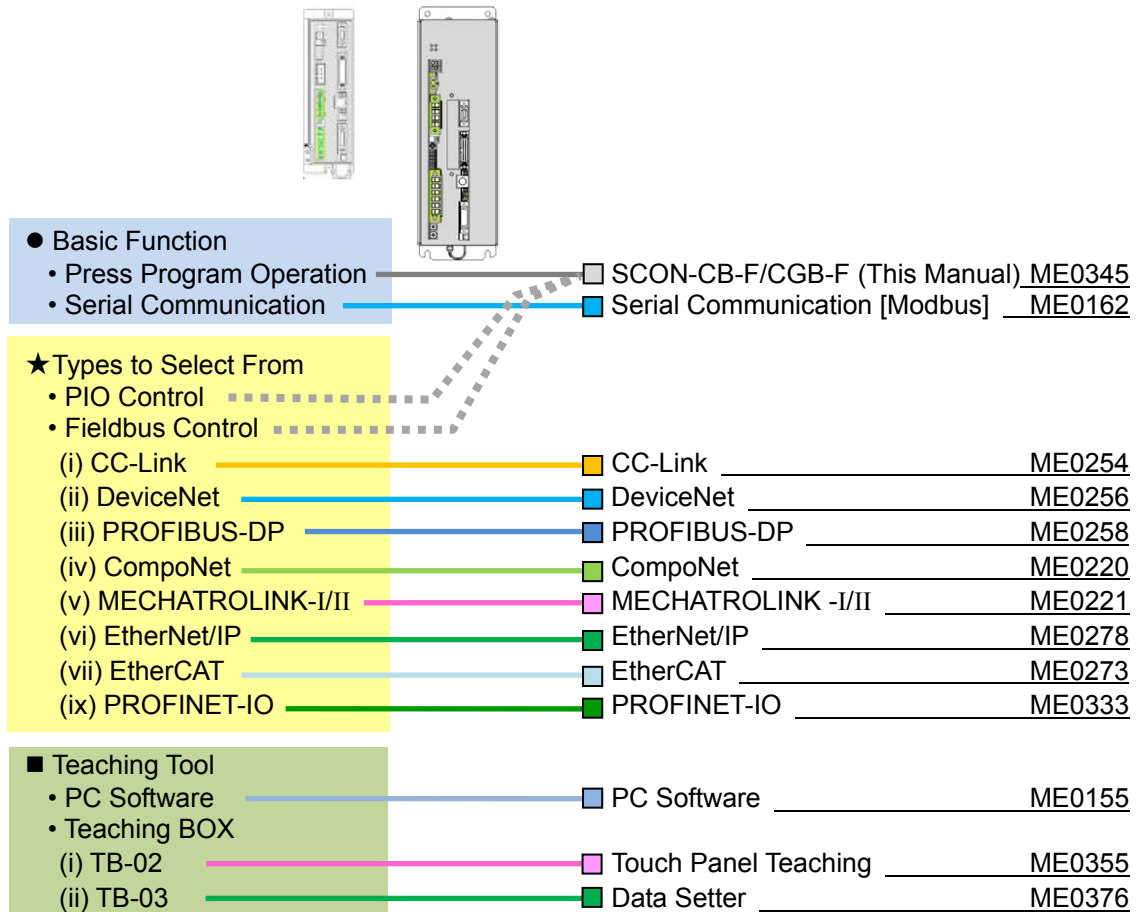

### SCON-LC/LCG Servo Press Type

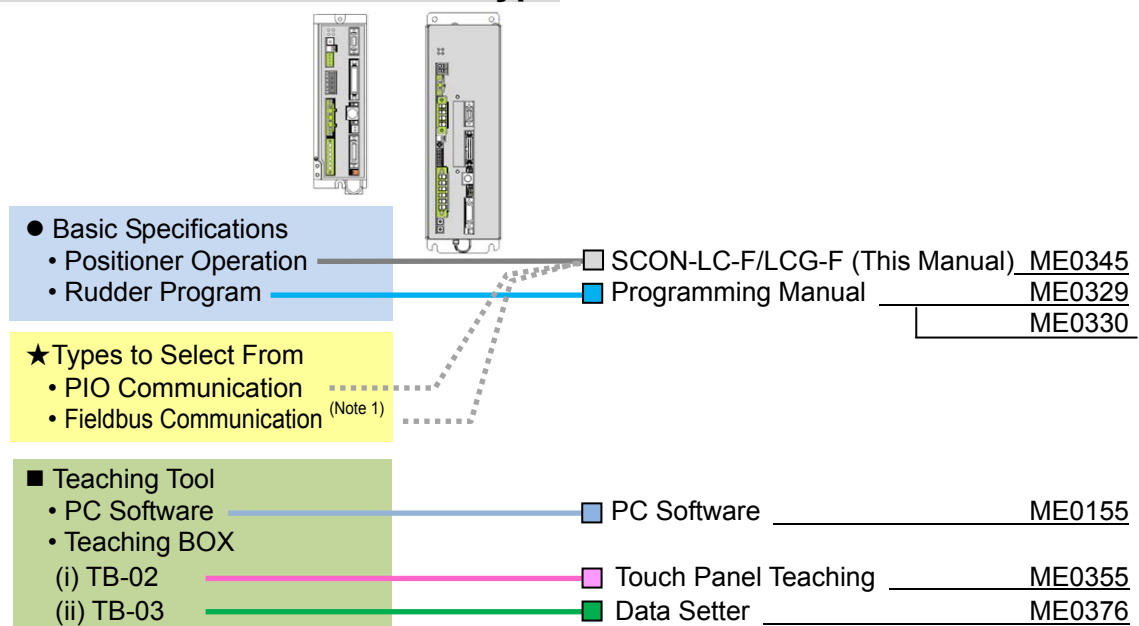

Note 1 CC-Link, DeviceNet, PROFIBUS-DP, CompoNet, MECHATROLINK-I/II, EtherNet/IP, EtherCAT, PROFINET-IO

Table of Overall Contents

<b>Name for Each Parts and Their Functions</b>	In this chapter, explains name for each parts and their functions.	<b>12</b>
<b>About SCON-LC Type</b>	In this chapter, explains the outline of LC (equipped with PLC feature) type.	<b>18</b>
<b>Chapter 1 Specifications Check</b>	In this chapter, explains about the specifications, current amperage, model codes and so on for the products.	<b>21</b>
<b>Chapter 2 Wiring</b>	In this chapter, explains actuator, connecting external device side.	<b>45</b>
<b>Chapter 3 Operation</b>	In this chapter, explains setting of press program and each operation mode. 3.1 Explain the Operation Mode 3.2 About Trial Run 3.3 About Operation with PIO	<b>103</b>
<b>Chapter 4 Applicability to Fieldbus</b>	In this chapter, explains applicable for fieldbus.	<b>135</b>
<b>Chapter 5 Feature of Multi-Function Connector</b>	In this chapter, explains how to use.	<b>139</b>
<b>Chapter 6 Absolute Type</b>	In this chapter, explains the procedures for absolute reset and replacement of battery.	<b>144</b>
<b>Chapter 7 Parameter</b>	In this chapter, explains how to set up or fine-tune the controller settings.	<b>147</b>
<b>Chapter 8 Troubleshooting</b>	In this chapter, explains how to act in errors and contents of them.	<b>180</b>
<b>Chapter 9 Appendix</b>	In this chapter, explains compliance with safety categories, model codes of connectable actuators, etc.	<b>199</b>
<b>Chapter 10 Warranty</b>	In this chapter, explains warranty.	<b>223</b>

## Table of Contents

Safety Guide .....	1
Precautions in Operation .....	8
International Standards Compliances .....	11
Name for Each Parts and Their Functions .....	12
About SCON-LC Type .....	18
Actuator Axes .....	20
Chapter 1 Specifications Check .....	21
1.1 Product Check .....	21
1.1.1 Parts .....	21
1.1.2 Teaching Tool .....	23
1.1.3 Instruction Manuals Related to this Product, which are Contained in the Instruction Manual (DVD) .....	23
1.1.4 How to Read the Model Plate .....	23
1.1.5 How to Read the Model .....	24
1.2 List of Basic Specifications .....	25
1.2.1 Specification List .....	25
1.2.2 Item for the Power Capacity and Heating Value .....	27
1.2.3 Selection of Circuit Breaker .....	27
1.2.4 Selection of Leakage Breaker .....	27
1.3 External Dimensions .....	28
1.3.1 SCON-CB/CGB/LC/LCG less than 400W .....	28
1.3.2 SCON-CB/CGB/LC/LCG 400W to 750W .....	28
1.3.3 SCON-CB/CGB/LC/LCG 3000W to 3300W .....	29
1.4 External Interface Specifications .....	30
1.4.1 Standard Input Output Interface Specification (Multi-Function Connector) .....	30
1.4.2 Input Output Interface Specification dedicated for PIO Type .....	31
1.4.3 Filedbus Type Specifications .....	32
1.5 Options .....	35
1.5.1 Regenerative Unit for Motors of up to 750W .....	35
1.5.2 Regenerative Unit for Motors of 3000W and above .....	36
1.5.3 Brake Box: RCB-110-RA13-0 .....	37
1.5.4 Load Cell .....	38
1.5.5 Pulse Converter: JM-08 .....	39
1.6 Installation and Storage Environment .....	40
1.7 Noise Elimination and Mounting Method .....	41
Chapter 2 Wiring .....	45
2.1 Servo Press Controller for Motors of up to 750W (PIO Control) .....	45
2.1.1 Wiring Diagram (Connection of Devices) .....	45
2.1.2 Wiring .....	46
2.2 Wiring for Controller for Motors of up to 750W .....	59
2.2.1 Wiring for Power Supply Circuit .....	59
2.2.2 Wiring of Emergency Stop Circuit (System I/O) .....	64
2.2.3 Connection of Actuator .....	66
2.2.4 Connection of PIO .....	68
2.2.5 Multi-function Connector .....	69
2.2.6 Connection of Regenerative Unit .....	72
2.2.7 SIO Connector Connection .....	74
2.3 Servo Press Controller for Motors of 3000W and above (PIO Control) .....	75
2.3.1 Wiring Diagram (Connection of Devices) .....	75
2.3.2 Wiring .....	76

2.4	Controller for Motors of 3000W and above	88
2.4.1	Wiring for Power Supply Circuit	88
2.4.2	Wiring of Emergency Stop Circuit (System I/O)	92
2.4.3	Connection of Actuator	94
2.4.4	Connection of PIO	96
2.4.5	Multi-function Connector	97
2.4.6	Connection of Regenerative Unit	100
2.4.7	SIO Connector Connection	102
Chapter 3 Operation		103
3.1	Explain the Operation Mode and Setting	103
3.1.1	Power Supply and Cutoff	103
3.1.2	Explain the Operation Mode	104
3.1.3	Basic Operation Setting	110
3.1.4	Detailed Settings (Optional Settings)	117
3.2	Trial Run	122
3.2.1	Manual Operation (Jog etc)	122
3.2.2	Press Program Operation	123
3.3	Operation with PIO	125
3.3.1	I/O Signal Controls	125
3.3.2	Operation Ready and Auxiliary Signals	125
3.3.3	Operation	130
Chapter 4 Applicability to Fieldbus		135
Chapter 5 Feature of Multi-function Connector		139
5.1	Feedback Pulse Output	139
5.1.1	Setting	139
5.2	Analog Output of Load Data	142
5.2.1	Specification	142
5.2.2	Setting	142
5.2.3	Rated Capacity of Loadcell Mounted to Each Actuator	142
5.3	Serial Communication 2 (SIO2)	143
5.3.1	Specification	143
5.3.2	Setting	143
Chapter 6 Absolute Type		144
6.1	Absolute Reset	144
6.2	Absolute Battery	145
6.2.1	Absolute Encoder Backup Specifications	145
6.2.2	Replacement of Absolute Battery	146
Chapter 7 Parameter		147
7.1	Parameter List	148
7.2	Detail Explanation of Parameters	151
7.3	Servo Adjustment	178
Chapter 8 Troubleshooting		180
8.1	Action Taken upon Occurrence of Problem	180
8.2	Fault Diagnosis	181
8.2.1	Impossible Operation of Controller	181
8.2.2	Generation of Noise and/or Vibration	181
8.3	Alarm Level	182
8.4	Alarm List	183
8.4.1	Controller Alarm (Excluding Program Alarm)	183
8.4.2	Program Alarm (When Controller alarm 094 is issued)	193



Chapter 9 Appendix .....	199
9.1 Way to Set Multiple Controllers with 1 Teaching Tool .....	199
9.1.1 Connecting Example .....	199
9.1.2 Detailed Connection Diagram of Communication Lines .....	200
9.1.3 Axis No. Setting .....	201
9.1.4 Handling of e-CON Connector (How to Connect) .....	202
9.1.5 SIO Converter .....	203
9.1.6 Communications .....	205
9.1.7 External Dimension .....	205
9.2 Conformity to Safety Category of to 750W motor corresponding SCON .....	206
9.3 Maintenance .....	217
9.4 List of Specifications of Connectable Actuators .....	218
9.4.1 List of Specifications for Actuator Operation Conditions .....	218
9.4.2 Specifications and Limitations in Pressing Operation .....	218
Chapter 10 Warranty .....	223
10.1 Warranty Period .....	223
10.2 Scope of the Warranty .....	223
10.3 Honoring the Warranty .....	223
10.4 Limited Liability .....	223
10.5 Conditions of Conformance with Applicable Standards/Regulations, Etc., and Applications .....	224
10.6 Other Items Excluded from Warranty .....	224
Change History .....	225



## ★ Starting Procedures ★

### Step 1 Confirm All the Necessary Things are Prepared (Contact us or our sales agency in case of any missing)

Refer to the section this manual “1.1 Product Check” for more detail.

#### ★ Controller (SCON-CB-F)



\* Check also enclosed parts  
[Refer to section 1.1.1]

#### ★ Actuator and Connecting Cable

(The cable differs depending on the actuator type. [Refer to Step3])



#### ★ CD-ROM (Enclosed in RCM-101-□□)

(The following software is included)

- RC PC Software



#### ★ DVD Instruction Manual

(includes the following instruction manuals)

[Refer to 1.1.3 Operation Manuals related to this product, which are provided on the DVD more detail.]

- 1) SCON-CB/LC-F Servo Press Function Instruction Manual (This manual)
- 2) RC PC Software Instruction Manual (ME0155)
- 3) LC Ladder Programming Manual (ME0329)
- 4) Touch Panel Taching Instruction Manual (ME0324)
- 5) Each Fieldbus Instruction Manual (ME0254, etc.)
- 6) Each Actuator Instruction Manual



#### ★ PLC Feature Equipped Type:

**Ladder Edit Program (LC-LDS-01)**

#### ★ For Fieldbus Type :

**Field Network Setting File (EDS File etc.)**

Download it in IAI homepage.

<http://www.iai-robot.co.jp/>



### Step 2 Check How to Operate

This product is a controller dedicated for servo press function. (It cannot conduct positioner operation or pulse train control.)

#### ★ What is Servo Press Function

It is a pressing method using the servomotor. There are two types of control available. One is the velocity control mode which conducts positioning operation to the set position, and the other is the force control mode which conducts pressing with the set load considered as the target pressing force.

CB/CGB Type

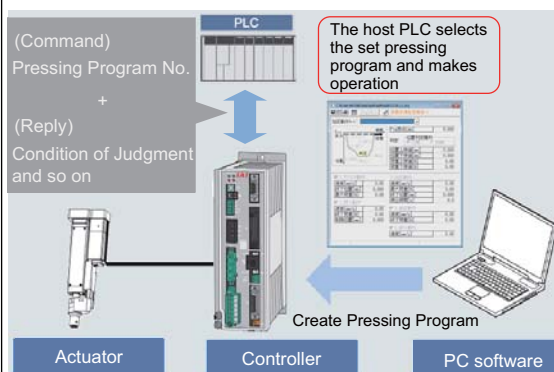

LC/LCG Type

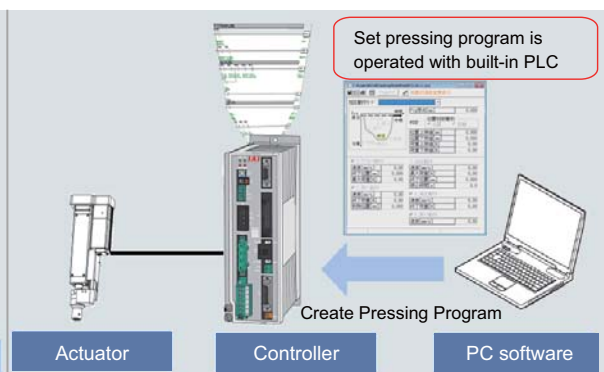

#### ★ What is Fieldbus Control

Fieldbus communication is used instead of connected with and controlled by PIO. Without using position data, operation can also be made by inputting numbers directly.

#### (Reference) What is Positioner Operation...(Unavailable)

Operation is conducted by setting the target position, velocity and so on in the position table in advance and indicating the position number.

#### (Reference) What is Pulse Train Control...(Unavailable)

Send the pulse corresponding to the movement amount of the actuator to the controller from a tool such as the positioning unit.

Check the operation modes and control methods available on the controller you have purchased. It can be defined on the controller model code shown on the label in the front face of the controller.

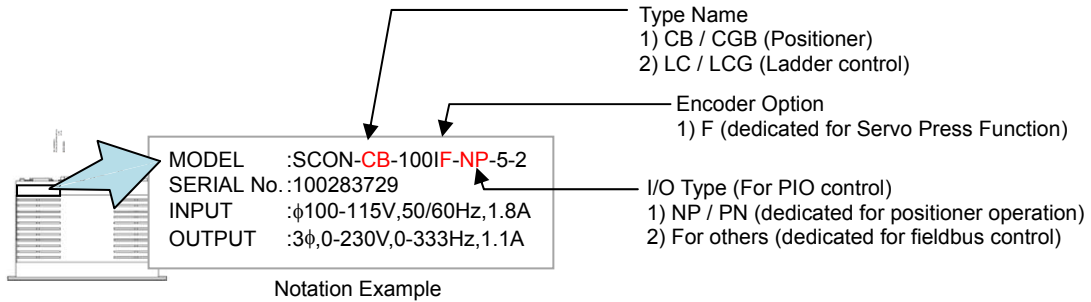

### Step 3 Installation "Refer to 1.6 Installation and Storage Environment" "1.7 Noise Elimination and Mounting Method"

- External Dimensions \* Check in 1.3 Appearance Dimensions.
- Grounding for Noise Prevention (Frame Ground)

#### Controller unit (~750W)

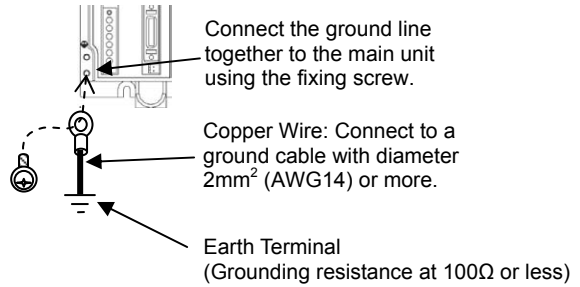
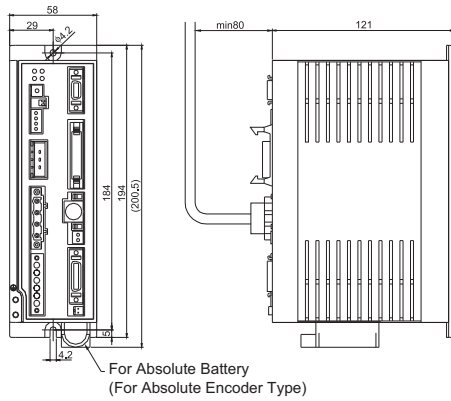

#### Controller unit (3000~3300W)

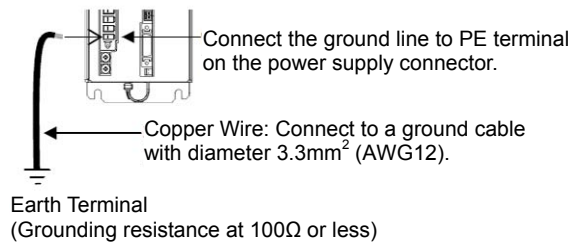
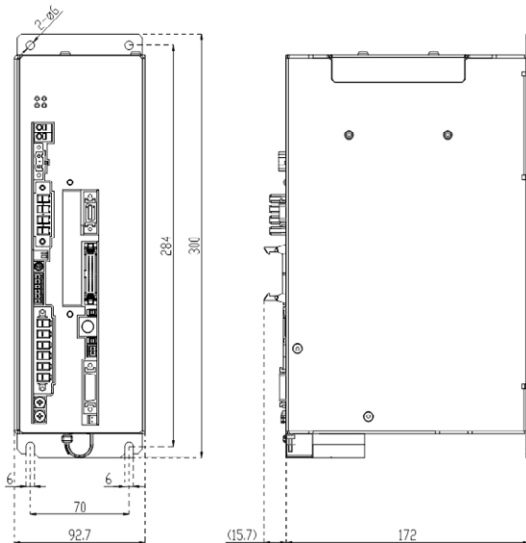

- Heat Radiation and Installation

Keep the ambient temperature of the controller at 40°C or less.

To fix the units in the control box, use the attachment holes on top and bottom of the unit for the screw-fixed type. Install in the orientation shown in the figure below for heat radiation.

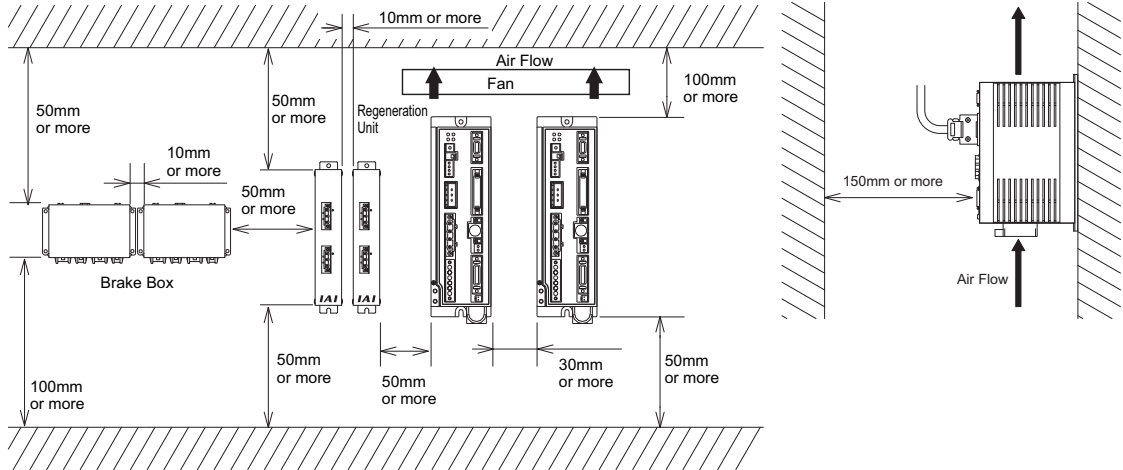

For 3000 ~ 3300W type

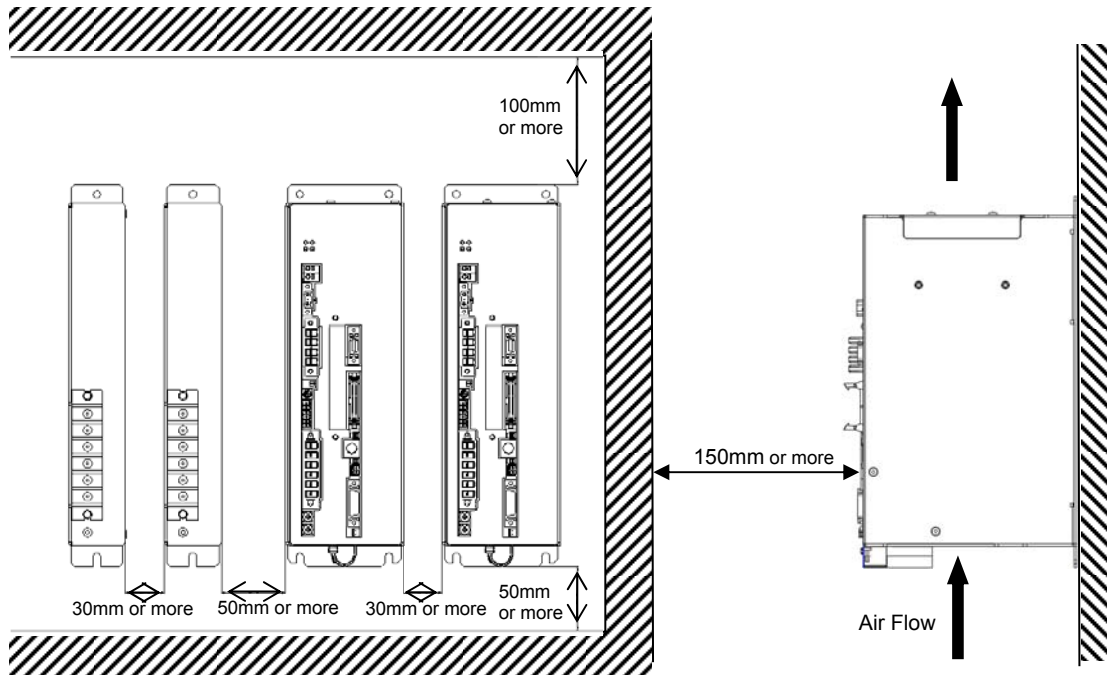

## Step 4 Wiring

## Refer to Chapter 2 "Wiring"

\* Refer in Chapter 4 for Fieldbus Type.

● Example for Basic Connection 1 (~ 750W or less)

Regenerative Resistor Unit (RESU-2 : option)  
Required depending on usage condition

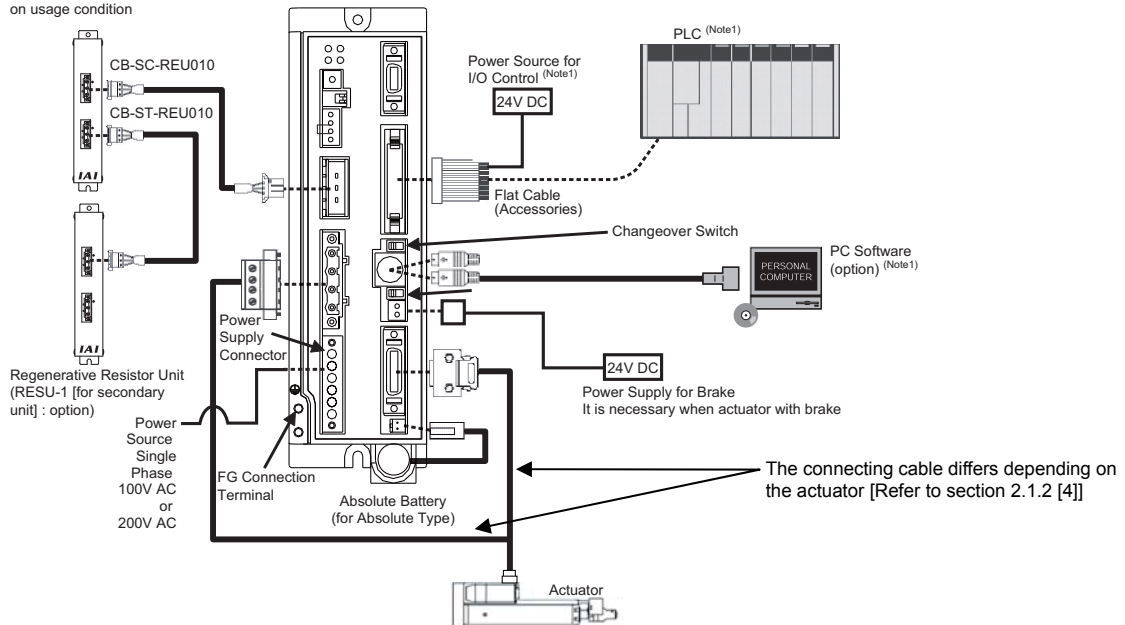

● Example for Basic Connection 2 (3000~ 3300W)

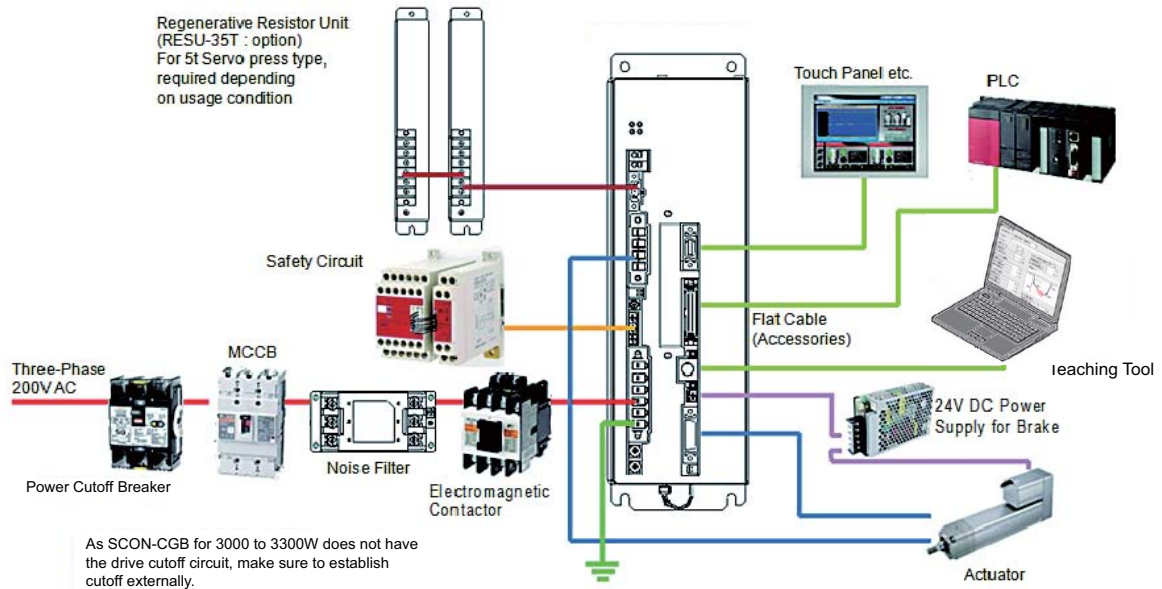

## Step 5 Operation

How you should look in the instruction manuals will differ depending on the operation modes and control methods you choose.

Establish the settings for your operation needs.

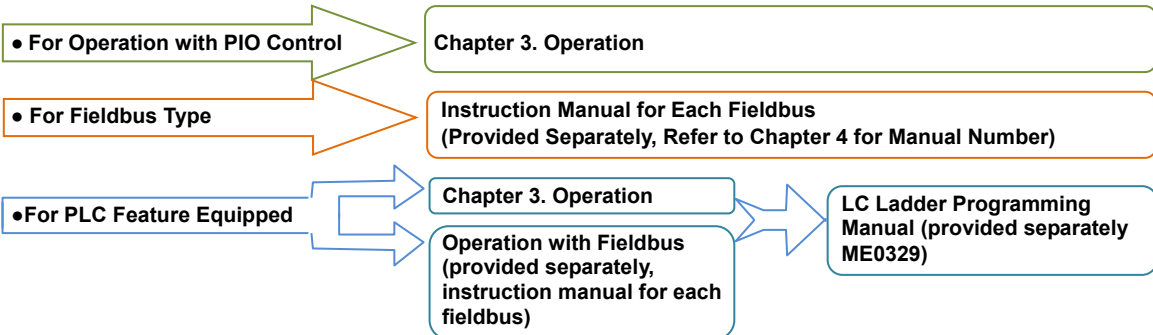

**Caution** Set it away from the mechanical end or peripherals as much as possible when turning the servo ON. Move it apart when it interferes with peripherals. It may generate an alarm if it hits to the mechanical end or peripherals when the servo is turned ON. Also, in case the actuator is installed in vertical orientation, turning ON/OFF the servo at the same spot may cause a slight drop by the self-gravity. Pay attention not to pinch your finger or damage a work piece.

**Caution** Pay attention not to pinch your finger or damage a work piece by dropping the actuator with self-gravity when it is released compulsorily with the brake release switch placed on the front panel of this controller.

**Caution** This controller is equipped with a safety velocity function to make the operation in low speed compulsorily. It is recommended to have this function activated in the first operation.

**SCON** 

---

---



## Safety Guide

“Safety Guide” has been written to use the machine safely and so prevent personal injury or property damage beforehand. Make sure to read it before the operation of this product.

### Safety Precautions for Our Products

The common safety precautions for the use of any of our robots in each operation.

No.	Operation Description	Description
1	Model Selection	<ul style="list-style-type: none"> <li>● This product has not been planned and designed for the application where high level of safety is required, so the guarantee of the protection of human life is impossible. Accordingly, do not use it in any of the following applications.               <ol style="list-style-type: none"> <li>1) Medical equipment used to maintain, control or otherwise affect human life or physical health.</li> <li>2) Mechanisms and machinery designed for the purpose of moving or transporting people (For vehicle, railway facility or air navigation facility)</li> <li>3) Important safety parts of machinery (Safety device, etc.)</li> </ol> </li> <li>● Do not use the product outside the specifications. Failure to do so may considerably shorten the life of the product.</li> <li>● Do not use it in any of the following environments.               <ol style="list-style-type: none"> <li>1) Location where there is any inflammable gas, inflammable object or explosive</li> <li>2) Place with potential exposure to radiation</li> <li>3) Location with the ambient temperature or relative humidity exceeding the specification range</li> <li>4) Location where radiant heat is added from direct sunlight or other large heat source</li> <li>5) Location where condensation occurs due to abrupt temperature changes</li> <li>6) Location where there is any corrosive gas (sulfuric acid or hydrochloric acid)</li> <li>7) Location exposed to significant amount of dust, salt or iron powder</li> <li>8) Location subject to direct vibration or impact</li> </ol> </li> <li>● For an actuator used in vertical orientation, select a model which is equipped with a brake. If selecting a model with no brake, the moving part may drop when the power is turned OFF and may cause an accident such as an injury or damage on the work piece.</li> </ul>

No.	Operation Description	Description
2	Transportation	<ul style="list-style-type: none"> <li>● When carrying a heavy object, do the work with two or more persons or utilize equipment such as crane.</li> <li>● When the work is carried out with 2 or more persons, make it clear who is to be the leader and who to be the follower(s) and communicate well with each other to ensure the safety of the workers.</li> <li>● When in transportation, consider well about the positions to hold, weight and weight balance and pay special attention to the carried object so it would not get hit or dropped.</li> <li>● Transport it using an appropriate transportation measure. The actuators available for transportation with a crane have eyebolts attached or there are tapped holes to attach bolts. Follow the instructions in the instruction manual for each model.</li> <li>● Do not step or sit on the package.</li> <li>● Do not put any heavy thing that can deform the package, on it.</li> <li>● When using a crane capable of 1t or more of weight, have an operator who has qualifications for crane operation and sling work.</li> <li>● When using a crane or equivalent equipments, make sure not to hang a load that weighs more than the equipment's capability limit.</li> <li>● Use a hook that is suitable for the load. Consider the safety factor of the hook in such factors as shear strength.</li> <li>● Do not get on the load that is hung on a crane.</li> <li>● Do not leave a load hung up with a crane.</li> <li>● Do not stand under the load that is hung up with a crane.</li> </ul>
3	Storage and Preservation	<ul style="list-style-type: none"> <li>● The storage and preservation environment conforms to the installation environment. However, especially give consideration to the prevention of condensation.</li> <li>● Store the products with a consideration not to fall them over or drop due to an act of God such as earthquake.</li> </ul>
4	Installation and Start	<p>(1) Installation of Robot Main Body and Controller, etc.</p> <ul style="list-style-type: none"> <li>● Make sure to securely hold and fix the product (including the work part). A fall, drop or abnormal motion of the product may cause a damage or injury. Also, be equipped for a fall-over or drop due to an act of God such as earthquake.</li> <li>● Do not get on or put anything on the product. Failure to do so may cause an accidental fall, injury or damage to the product due to a drop of anything, malfunction of the product, performance degradation, or shortening of its life.</li> <li>● When using the product in any of the places specified below, provide a sufficient shield.             <ol style="list-style-type: none"> <li>1) Location where electric noise is generated</li> <li>2) Location where high electrical or magnetic field is present</li> <li>3) Location with the mains or power lines passing nearby</li> <li>4) Location where the product may come in contact with water, oil or chemical droplets</li> </ol> </li> </ul>

No.	Operation Description	Description
4	Installation and Start	<p>(2) Cable Wiring</p> <ul style="list-style-type: none"> <li>● Use our company's genuine cables for connecting between the actuator and controller, and for the teaching tool.</li> <li>● Do not scratch on the cable. Do not bend it forcibly. Do not pull it. Do not coil it around. Do not insert it. Do not put any heavy thing on it. Failure to do so may cause a fire, electric shock or malfunction due to leakage or continuity error.</li> <li>● Perform the wiring for the product, after turning OFF the power to the unit, so that there is no wiring error.</li> <li>● When the direct current power (+24V) is connected, take the great care of the directions of positive and negative poles. If the connection direction is not correct, it might cause a fire, product breakdown or malfunction.</li> <li>● Connect the cable connector securely so that there is no disconnection or looseness. Failure to do so may cause a fire, electric shock or malfunction of the product.</li> <li>● Never cut and/or reconnect the cables supplied with the product for the purpose of extending or shortening the cable length. Failure to do so may cause the product to malfunction or cause fire.</li> </ul> <p>(3) Grounding</p> <ul style="list-style-type: none"> <li>● The grounding operation should be performed to prevent an electric shock or electrostatic charge, enhance the noise-resistance ability and control the unnecessary electromagnetic radiation.</li> <li>● For the ground terminal on the AC power cable of the controller and the grounding plate in the control panel, make sure to use a twisted pair cable with wire thickness 0.5mm<sup>2</sup> (AWG20 or equivalent) or more for grounding work. For security grounding, it is necessary to select an appropriate wire thickness suitable for the load. Perform wiring that satisfies the specifications (electrical equipment technical standards).</li> <li>● Perform Class D Grounding (former Class 3 Grounding with ground resistance 100Ω or below).</li> </ul>





No.	Operation Description	Description
4	Installation and Start	<p>(4) Safety Measures</p> <ul style="list-style-type: none"> <li>● When the work is carried out with 2 or more persons, make it clear who is to be the leader and who to be the follower(s) and communicate well with each other to ensure the safety of the workers.</li> <li>● When the product is under operation or in the ready mode, take the safety measures (such as the installation of safety and protection fence) so that nobody can enter the area within the robot's movable range. When the robot under operation is touched, it may result in death or serious injury.</li> <li>● Make sure to install the emergency stop circuit so that the unit can be stopped immediately in an emergency during the unit operation.</li> <li>● Take the safety measure not to start up the unit only with the power turning ON. Failure to do so may start up the machine suddenly and cause an injury or damage to the product.</li> <li>● Take the safety measure not to start up the machine only with the emergency stop cancellation or recovery after the power failure. Failure to do so may result in an electric shock or injury due to unexpected power input.</li> <li>● When the installation or adjustment operation is to be performed, give clear warnings such as "Under Operation; Do not turn ON the power!" etc. Sudden power input may cause an electric shock or injury.</li> <li>● Take the measure so that the work part is not dropped in power failure or emergency stop.</li> <li>● Wear protection gloves, goggle or safety shoes, as necessary, to secure safety.</li> <li>● Do not insert a finger or object in the openings in the product. Failure to do so may cause an injury, electric shock, damage to the product or fire.</li> <li>● When releasing the brake on a vertically oriented actuator, exercise precaution not to pinch your hand or damage the work parts with the actuator dropped by gravity.</li> </ul>
5	Teaching	<ul style="list-style-type: none"> <li>● When the work is carried out with 2 or more persons, make it clear who is to be the leader and who to be the follower(s) and communicate well with each other to ensure the safety of the workers.</li> <li>● Perform the teaching operation from outside the safety protection fence, if possible. In the case that the operation is to be performed unavoidably inside the safety protection fence, prepare the "Stipulations for the Operation" and make sure that all the workers acknowledge and understand them well.</li> <li>● When the operation is to be performed inside the safety protection fence, the worker should have an emergency stop switch at hand with him so that the unit can be stopped any time in an emergency.</li> <li>● When the operation is to be performed inside the safety protection fence, in addition to the workers, arrange a watchman so that the machine can be stopped any time in an emergency. Also, keep watch on the operation so that any third person can not operate the switches carelessly.</li> <li>● Place a sign "Under Operation" at the position easy to see.</li> <li>● When releasing the brake on a vertically oriented actuator, exercise precaution not to pinch your hand or damage the work parts with the actuator dropped by gravity.</li> </ul> <p>* Safety protection Fence : In the case that there is no safety protection fence, the movable range should be indicated.</p>

No.	Operation Description	Description
6	Trial Operation	<ul style="list-style-type: none"> <li>● When the work is carried out with 2 or more persons, make it clear who is to be the leader and who to be the follower(s) and communicate well with each other to ensure the safety of the workers.</li> <li>● After the teaching or programming operation, perform the check operation one step by one step and then shift to the automatic operation.</li> <li>● When the check operation is to be performed inside the safety protection fence, perform the check operation using the previously specified work procedure like the teaching operation.</li> <li>● Make sure to perform the programmed operation check at the safety speed. Failure to do so may result in an accident due to unexpected motion caused by a program error, etc.</li> <li>● Do not touch the terminal block or any of the various setting switches in the power ON mode. Failure to do so may result in an electric shock or malfunction.</li> </ul>
7	Automatic Operation	<ul style="list-style-type: none"> <li>● Check before starting the automatic operation or rebooting after operation stop that there is nobody in the safety protection fence.</li> <li>● Before starting automatic operation, make sure that all peripheral equipment is in an automatic-operation-ready state and there is no alarm indication.</li> <li>● Make sure to operate automatic operation start from outside of the safety protection fence.</li> <li>● In the case that there is any abnormal heating, smoke, offensive smell, or abnormal noise in the product, immediately stop the machine and turn OFF the power switch. Failure to do so may result in a fire or damage to the product.</li> <li>● When a power failure occurs, turn OFF the power switch. Failure to do so may cause an injury or damage to the product, due to a sudden motion of the product in the recovery operation from the power failure.</li> </ul>

No.	Operation Description	Description
8	Maintenance and Inspection	<ul style="list-style-type: none"> <li>● When the work is carried out with 2 or more persons, make it clear who is to be the leader and who to be the follower(s) and communicate well with each other to ensure the safety of the workers.</li> <li>● Perform the work out of the safety protection fence, if possible. In the case that the operation is to be performed unavoidably inside the safety protection fence, prepare the “Stipulations for the Operation” and make sure that all the workers acknowledge and understand them well.</li> <li>● When the work is to be performed inside the safety protection fence, basically turn OFF the power switch.</li> <li>● When the operation is to be performed inside the safety protection fence, the worker should have an emergency stop switch at hand with him so that the unit can be stopped any time in an emergency.</li> <li>● When the operation is to be performed inside the safety protection fence, in addition to the workers, arrange a watchman so that the machine can be stopped any time in an emergency. Also, keep watch on the operation so that any third person can not operate the switches carelessly.</li> <li>● Place a sign “Under Operation” at the position easy to see.</li> <li>● For the grease for the guide or ball screw, use appropriate grease according to the Instruction Manual for each model.</li> <li>● Do not perform the dielectric strength test. Failure to do so may result in a damage to the product.</li> <li>● When releasing the brake on a vertically oriented actuator, exercise precaution not to pinch your hand or damage the work parts with the actuator dropped by gravity.</li> <li>● The slider or rod may get misaligned OFF the stop position if the servo is turned OFF. Be careful not to get injured or damaged due to an unnecessary operation.</li> <li>● Pay attention not to lose the cover or untightened screws, and make sure to put the product back to the original condition after maintenance and inspection works. Use in incomplete condition may cause damage to the product or an injury.</li> </ul> <p>* Safety protection Fence : In the case that there is no safety protection fence, the movable range should be indicated.</p>
9	Modification and Dismantle	<ul style="list-style-type: none"> <li>● Do not modify, disassemble, assemble or use of maintenance parts not specified based at your own discretion.</li> </ul>
10	Disposal	<ul style="list-style-type: none"> <li>● When the product becomes no longer usable or necessary, dispose of it properly as an industrial waste.</li> <li>● When removing the actuator for disposal, pay attention to drop of components when detaching screws.</li> <li>● Do not put the product in a fire when disposing of it. The product may burst or generate toxic gases.</li> </ul>
11	Other	<ul style="list-style-type: none"> <li>● Do not come close to the product or the harnesses if you are a person who requires a support of medical devices such as a pacemaker. Doing so may affect the performance of your medical device.</li> <li>● See Overseas Specifications Compliance Manual to check whether complies if necessary.</li> <li>● For the handling of actuators and controllers, follow the dedicated instruction manual of each unit to ensure the safety.</li> </ul>

## Alert Indication

The safety precautions are divided into “Danger”, “Warning”, “Caution” and “Notice” according to the warning level, as follows, and described in the Instruction Manual for each model.

Level	Degree of Danger and Damage	Symbol
Danger	This indicates an imminently hazardous situation which, if the product is not handled correctly, will result in death or serious injury.	 <span style="margin-left: 10px;">Danger</span>
Warning	This indicates a potentially hazardous situation which, if the product is not handled correctly, could result in death or serious injury.	 <span style="margin-left: 10px;">Warning</span>
Caution	This indicates a potentially hazardous situation which, if the product is not handled correctly, may result in minor injury or property damage.	 <span style="margin-left: 10px;">Caution</span>
Notice	This indicates lower possibility for the injury, but should be kept to use this product properly.	 <span style="margin-left: 10px;">Notice</span>

## ■ Precautions in Operation ■

---

### 1. Use the following teaching tools.

In this controller servo press function for only use the PC software.  
[Refer to 1.1.2 Teaching Tool.]

### 2. Backup the data to secure for breakdown.

A non-volatile memory is used as the backup memory for this controller. All the registered press program and parameters are written into this memory and backed-up at the same time. Therefore, you will not usually lose the data even if the power is shut down. However, make sure to save the latest data so a quick recovery action can be taken in case when the controller is broken and needs to be replaced with another one.

How to Save Data

(1) Save the data to non-volatile memory with using the PC software.

### 3. Set the operation patterns.

Servo press type controller processes 9 types of control logics to meet various ways of usage. To select the operation mode can be performed by using the PC software.  
[Refer to Chapter 3 Operation]

Set the pressurize operation mode setting to the logic that suits to your use after the power is turned on.



Warning : SCON controller dedicated for the servo press function is to be operated with the dedicated press program.  
It cannot be operated with the positioner mode or pulse train control mode.

### 4. Clock setting in calendar function

There may be a case that alarm code 069 [Real Time Clock Vibration Stop Detect] is issued at the first time to turn the power on after the product is delivered. In the case this happens, set the current time with a teaching tool.

If the battery is fully charged, the clock data is retained for approximately 10 days after the power is turned off. Even though the time setting is conducted before the product is shipped out, the battery is not fully charged. Therefore, there may be a case that the clock data is lost even with fewer days than described above passed since the product is shipped out.

### 5. Actuator would not operate without servo-ON.

Servo ON signal (SON) is selectable from Enable or Disable by using a parameter.

The setup can be performed by using the Parameter No. 21 [To select the servo-ON signal input disable].

[Refer to Chapter 7 Parameter]

If it is set to Enable, the actuator would not operate unless turning this signal on.

If parameter No.21 is set to "1", SON is made disable.

If it is set to Disable, the servo becomes on and the actuator operation becomes enabled as soon as the power supply to the controller is turned on and the emergency stop signal is cancelled.

[Refer to 3.3.2 [1] Preparation for Operation and Supportive Signal]

It is set to "0" (enable) at delivery. Establish the settings considering the using control systems.



## 6. About the create a sequence program

Please note the following when create a sewence program.

To certainly transfer the signal between controllers with different scan time, it is necessary to have longer scan time than the one longer than the other equipment. (To ensure to end the process safely, it is recommended to have the timer setting more than twice as long as the longer scan time at least)

### • Operation Image

Host Controller

(e.g. scan time is 20msec)

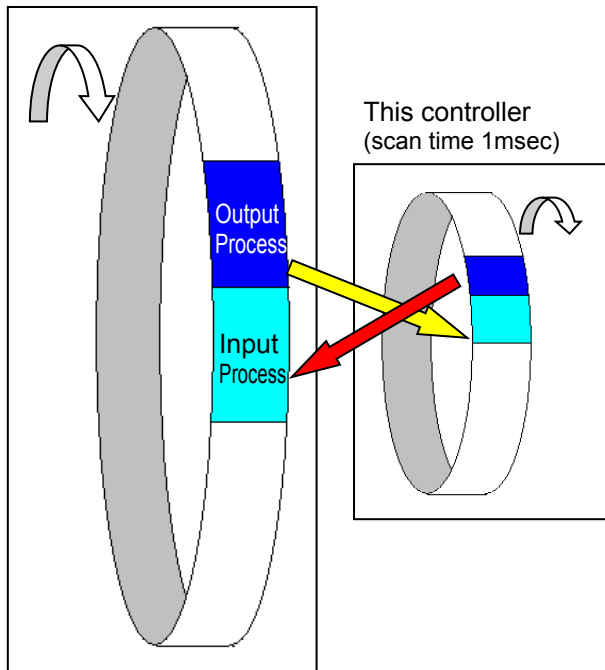

As shown in the diagram, the input and output timings of two devices that have different scan time do not match, of course, when transferring a signal.

There is no guarantee that PLC would read the signal as soon as this controller signal turns on. In such a case, make the setting to read the signal after a certain time that is longer than the longer scan time to ensure the reading process to succeed on the PLC side.

It is the same in the case this controller side reads the signal.

In such a case, it is recommended to ensure 2 to 4 times of the scan time for the timer setting margin.

It is risky to have the setting below the scan time since the timer is also processed in the scan process.

In the diagram, host controller can only read the input once in 20msec even though this controller output once in 1msec.

Because host controller only conducts output process once in 20msec, this controller identifies the same output status for that while.

Also, if one tries to read the signal that is being re-written by the other, the signal may be read wrongly. Make sure to read the signal after the rewriting is complete. (It is recommended to have more than 2 scan periods to wait.) Make sure not to have the output side to change the output until the other side completes the reading. Also, a setting is made on the input area not to receive the signal less than a certain time to prevent a wrong reading of noise. This duration also needs to be considered.

## 7. PLC timer setting

Do not have the PLC timer setting to be done with the minimum setting.

Setting to "1" for 100msec timer turns ON at the timing from 0 to 100msec while 10msec timer from 0 to 10msec for some PLC.

Therefore, the same process as when the timer is not set is held and may cause a failure, and set "2" as the minimum value for the setting of 10msec timer and when setting to 100msec, use 10msec timer and set to "10".

## 8. Handling of built-in drive cutoff relay and cautions in caution in handling

The product equips a built-in drive cutoff relay, and it is necessary to be careful in handling. Use the product with narrow understanding to the following notes.

- The drive cutoff relay built in our controllers is designed under assumption of limited frequency of use such as a case to require emergency stop of a system, and frequent operation is not considered. Therefore, in a condition to require high frequency of use of the drive cutoff relay such as a case to turn ON/OFF the driving source in every setup change, the life of the relay may reach to the end in early stage.
- The relay itself may not meet a sufficient safety demand level when it is used in a system that prioritizes safety in the drive cutoff system. It is necessary to construct a system to meet the safety demand level in a circuit that a customer prepares.
- IAI products equip a built-in drive cutoff relay considering customer's usage. However, as described above, whether it can be used or not relies on such facts as the safety demand level and frequency of drive cutoff. Please use it in limitation to the way to use as described below.
- Do not expect reliability of the drive cutoff relay (Anything can do as long as driving source can be cut off.)
- Take around 5 times a day as a reference to turn ON/OFF the drive cutoff relay
- Thermistor type (which the resistance gets high and restrains in-rush current in low temperature, and resistance gets low and reduce loss in high temperature) in-rush current limiter circuit is equipped. Therefore, to keep the thermistor temperature as low as possible when turning the power on is a key point to make degradation slower on such components as the drive cutoff relay. As a reference, it is preferred to have approximately 30 minutes for cooling after the driving source being cut off.

(Note) There is no built-in drive cutoff relay equipped in those types for 3000W or more.  
Establish the construction of the circuit to have an external cutoff.

## 9. Regarding Servo Press Equipment (Device)

- Regarding the safety circuit, make sure to establish the construction that satisfies the safety requirements as the system by having the risk assessment conducted on the device by its own.
- Have the safety protection fences. Also, make sure to install safety equipment in order to cut off the power supply when an operator gets into the working area.
- Install the controller inside the enclosure of the control panel.
- The circuit inside the controller is charged with high voltage. Do not attempt to touch it while the electricity is conducted or after conduction (when Charge Status Display LED lamp is on). It may cause electric shock.
- The controller temperature gets high. Do not attempt to touch it.

## ■ International Standards Compliances ■

This product comply with the following international standards:  
 Refer to Overseas Standard Compliance Manual (ME0287) for more detailed information.

Controller	RoHS Directive	CE Marking	UL
SCON-(For Servo Press)	○	Please contact IAI	○ (to 750W) × (3000 to 3300W)

### UL

#### 1. Use Environment

- It can be used in pollution degree 2 environment.
- Maximum surrounding air temperature rating, 40°C ;

#### 2. Solid State Motor Overload Protection

Solid state motor overload protection in the SCON controller is provided.  
 The overload protection works at 115% of the whole load current of the servomotor as the criteria.

#### 3. Short Circuit Current Rating (SCCR)

This product is to be used with a power supply of 5,000Arms or lower. The available maximum voltage is as shown below:

- 200V system products: 240V AC
- 100V system products: 120V AC

#### 4. Branch Circuit Protection

Integral solid state short circuit protection does not provide branch circuit protection. Branch circuit protection must be provided in accordance with the National Electric Code and any additional local codes.

#### 5. Risk of Electric Shock

Do not touch terminals within 10 minutes after disconnect the power. Risk of electric shock.

## ■ Name for Each Parts and Their Functions ■

- ~750W Type

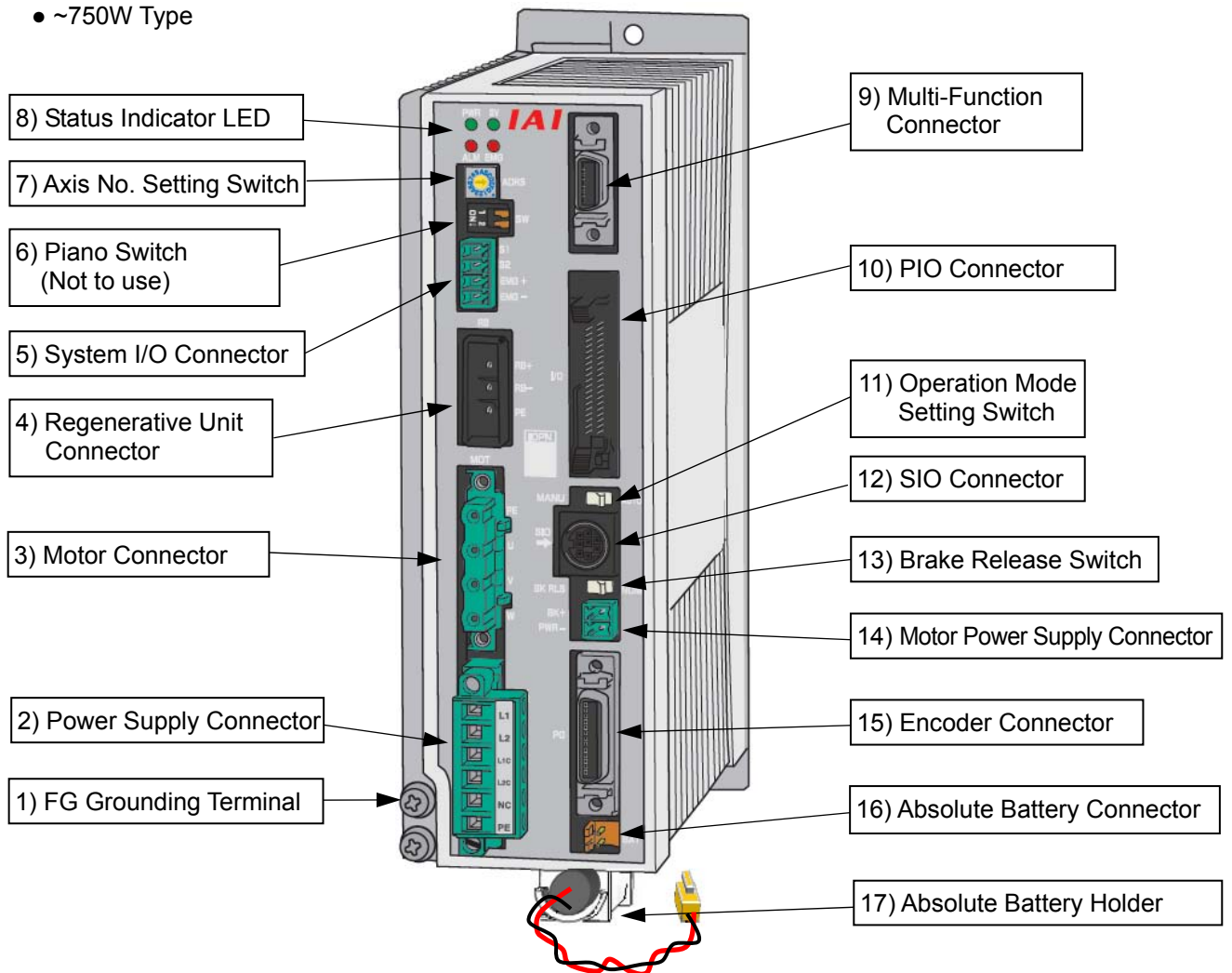

- 1) FG Grounding Terminal [Refer to 1.7 Installation and Noise Prevention]  
It is a terminal to connect the grounding line to prevent electric shock and noise. It is connected with the PE of the power connector in the controller.
- 2) Power Supply Connector (PWR) [Refer to 2.1.2 [1] Main Power Circuit]  
It is the connector to supply the power to the controller and to the control board.
- 3) Motor Connector (MOT) [Refer to 2.1.2 [4] Motor • Encoder Circuit]  
It is a connector to connecting the motor encoder cable of the actuator.
- 4) Regenerative Unit Connector (RB) [Refer to 2.1.2 [6] Regenerative Unit Circuit]  
It is a connector to connecting regenerative unit.
- 5) System I/O Connector (SYS I/O) [Refer to 2.1.2 [3] Actuator Emergency Stop Circuit (System I/O connector)]  
It is a connector to connecting the operation mode stop switch of the actuator.

6) Piano Switch  
Not to use.

7) Axis No. Setting Switch (ADRS)

This switch is used to set an axis number in multi-axis operation through serial communication. Using the SIO converter allows multiple axes to be controlled on a teaching tool such as a PC without connection/disconnection of the connection cable connector. The SIO converter can specify up to 16 axes with hexadecimal numbers 0 to F. [Refer to 9.1.3 Axis No. Setting.] The setting of the switch is read at power-on of the controller. Changing the setting after the power-on is invalid.

Point the arrow at a desired number with a slotted screwdriver

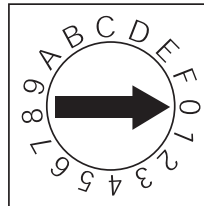

**Caution :** Note duplicate axis number setting, which causes a communication error (alarm code 30C: no connection axis error) to occur and disables normal communication.

8) Status Indicator LED (PWR, SV, ALM, EMG)

Following show the controller operation status:

○ : Illuminating   × : OFF   Δ : Undefined (flashing or OFF)

LED				Operation Status
PWR (Green)	SV (Green)	ALM (Orange)	EMG (Red)	
×	×	×	×	Control power supply OFF
○	×	×	×	Controller in normal startup
○	×	×	×	Servo OFF
○	○ <sup>(Note 1)</sup>	×	×	Servo ON
○	×	○	Δ	Alarm being generated
○	×	Δ	○	In emergency stop condition
○	Δ	Δ	Δ	Warning being generated

Note 1   Blinking in auto servo-OFF state. Blinking in 1Hz

9) Multi-Function Connector (MF I/F) [Refer to 2.1.2 [7] Multi-Function Connector]  
 It is a connector to use the feedback pulse output, analog output of loadcell load data and SIO communication function (SIO2).

10) PIO Connector (PIO) [Refer to 2.1.2 [5] PIO Circuit]  
 The PIO connector is used for control I/O signals.  
 (Note) It is not mounted in fieldbus type.

11) Operation Mode Setting Switch (MANU/AUTO)  
 The switch for interlock.

Setting to switch	SCON-CB	SCON-LC
AUTO	Allows auto operation by PIO signals. The teaching tool can only operate the monitor.	Allows operation by Ladder. The teaching tool can only operate the monitor.
MANU	Allows the teaching tool to operate the controller.	The ladder stops. Allows the teaching tool to operate the controller.

12) SIO Connector (SIO) [Refer to 2.2.7 SIO Connector]  
 The SIO connector is used to connect the controller with a teaching tool such as PC software or a gateway unit through a proper communication cable.

13) Brake Release Switch (BK RLS /NOM)  
 For the actuator equipped with a brake, the switch is used to release the brake control.

	<p>Warning : Always set the switch to NOM in normal operation.          The brake would not work even with the servo OFF condition if the switch is on the RLS side. In the vertical oriented mount, the work may drop and cause an injury or the work to be damaged.</p>
---	---

14) Motor Power Supply Connector (BK PWR) [2.1.2 [2] Brake Power Supply Circuit]  
 For the actuator equipped with a brake, the connector supplies the power (24V DC) to release the brake.

15) Encoder Connector (PG) [Refer to 2.1.2 [4] Motor • Encoder Circuit]  
 This connector is used to connect the encoder cable of the actuator.

16) Absolute Battery Connector  
 In the absolute specification, the connector is connected with the absolute battery.

17) Absolute Battery Holder (enclosed in the absolute specification)  
 This is the holder of the absolute battery.

- ~3000W Type

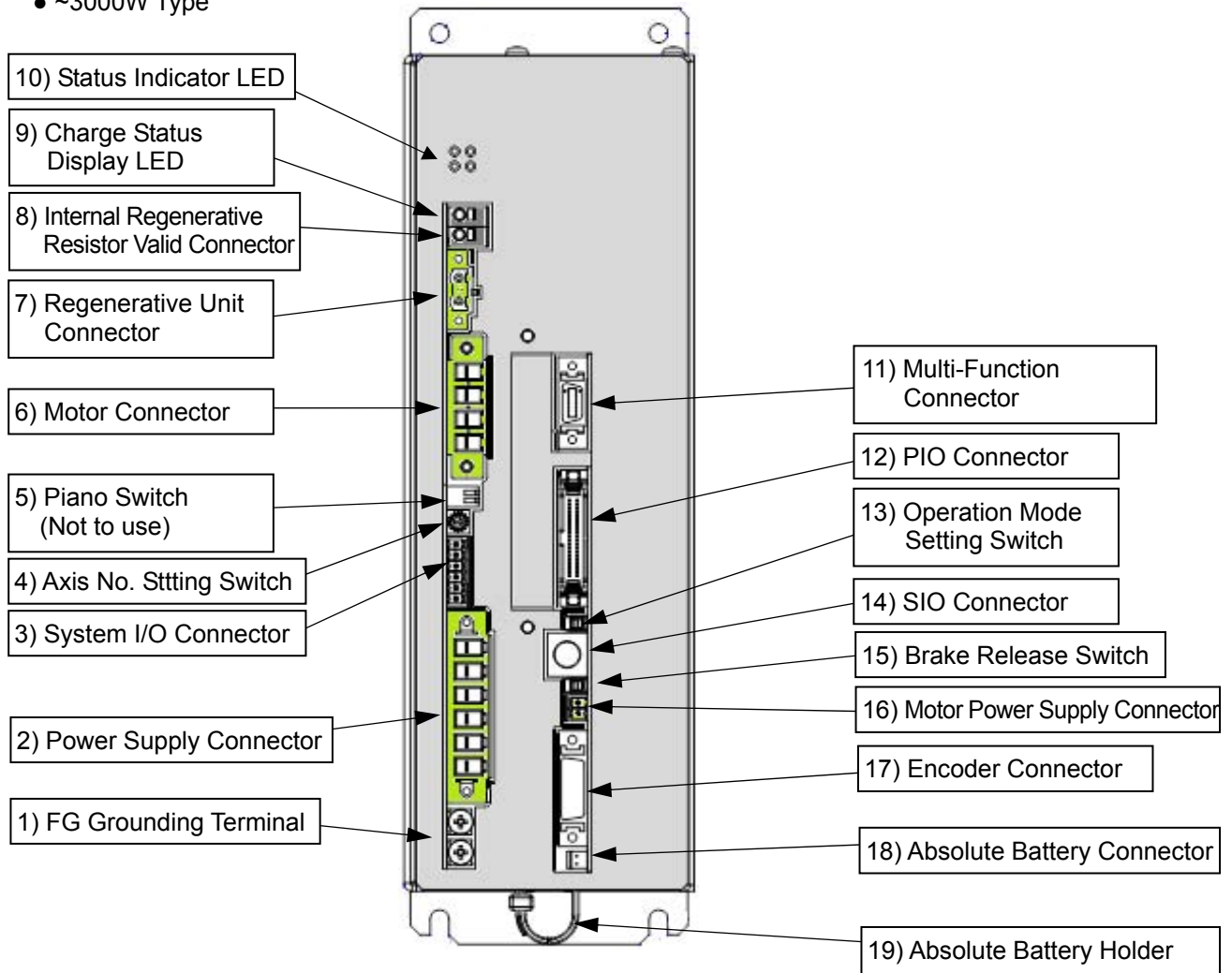



- 1) FG Grounding Terminal [Refer to 1.7 Installation and Noise Prevention]  
It is a terminal to connect the grounding line to prevent electric shock and noise. It is connected with the PE of the power connector in the controller.
- 2) Power Supply Connector (PWR) [Refer to 2.3.2 [1] Main Power Circuit]  
It is the connector to supply the power to the controller and to the control board.
- 3) System I/O Connector (SYS I/O) [Refer to 2.3.2 [3] Actuator Emergency Stop Circuit (System I/O connector)]  
It is a connector to connecting the operation mode stop switch of the actuator.

#### 4) Axis No. Sttting Switch (ADRS)

This switch is used to set an axis number in multi-axis operation through serial communication. Using the SIO converter allows multiple axes to be controlled on a teaching tool such as a PC without connection/disconnection of the connection cable connector. The SIO converter can specify up to 16 axes with hexadecimal numbers 0 to F. [Refer to 9.1.3 Axis No. Setting.] The setting of the switch is read at power-on of the controller. Changing the setting after the power-on is invalid.

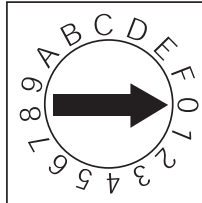
Point the arrow at a desired number with a slotted screwdriver



 **Caution :** Note duplicate axis number setting, which causes a communication error (alarm code 30C: no connection axis error) to occur and disables normal communication.

#### 5) Piano Switch Not to use.

#### 6) Motor Connector (MOT) [Refer to 2.3.2 [4] Motor • Encoder Circuit] It is a connector to connecting the motor encoder cable of the actuator.

#### 7) Regenerative Unit Connector (RB) [Refer to 2.3.2 [6] Regenerative Unit Circuit] It is a connector to connecting regenerative unit.

#### 8) Internal Regenerative Resistor Valid Connector Short-circuit cable is connected at delivery.

 **Caution :** Make sure to use the unit in the condition that the short-circuit cable is connected.  
Use the unit without this connected may damage the device.

#### 9) Charge Status Display LED It shows the status of electric charge in the controller.

 **Caution :** While this LED lamp is on, do not attempt to touch controller or regenerative resistor units to prevent electric shock.

#### 10) Status Indicator LED (PWR, SV, ALM, EMG)

Following show the controller operation status:

○ : Illuminating   × : OFF   Δ : Undefined (flashing or OFF)

LED				Operation Status
PWR (Green)	SV (Green)	ALM (Orange)	EMG (Red)	
×	×	×	×	Control power supply OFF
○	×	×	×	Controller in normal startup
○	×	×	×	Servo OFF
○	○ (Note 1)	×	×	Servo ON
○	×	○	Δ	Alarm being generated
○	×	Δ	○	In emergency stop condition
○	Δ	Δ	Δ	Warning being generated

Note 1   Blinking in auto servo-OFF state



11) Multi-Function Connector (MF I/F) [Refer to 2.3.2 [7] Multi-Function Connector]  
 It is a connector to use the feedback pulse output, analog output of loadcell load data and SIO communication function (SIO2).

12) PIO Connector (PIO) [Refer to 2.3.2 [5] PIO Circuit]  
 The PIO connector is used for control I/O signals.  
 (Note) It is not mounted in fieldbus type.

13) Operation Mode Setting Switch (MANU/AUTO)  
 The switch for interlock.

Setting to switch	SCON-CB	SCON-LC
AUTO	Allows auto operation by PIO signals. The teaching tool can only operate the monitor.	Allows operation by Ladder. The teaching tool can only operate the monitor.
MANU	Allows the teaching tool to operate the controller.	The ladder stops. Allows the teaching tool to operate the controller.

14) SIO Connector (SIO) [Refer to 2.4.7 SIO Connector]  
 The SIO connector is used to connect the controller with a teaching tool as PC software through a proper communication cable.

15) Brake Release Switch (BK RLS /NOM)  
 For the actuator equipped with a brake, the switch is used to release the brake control.

 **Warning :** Always set the switch to NOM in normal operation.  
 The brake would not work even with the servo OFF condition if the switch is on the RLS side. In the vertical oriented mount, the work may drop and cause an injury or the work to be damaged.

16) Motor Power Supply Connector (BK PWR) [2.3.2 [2] Brake Power Supply Circuit]  
 For the actuator equipped with a brake, the connector supplies the power (24V DC) to release the brake.

17) Encoder Connector (PG) [Refer to 2.3.2 [4] Motor • Encoder Circuit]  
 This connector is used to connect the encoder cable of the actuator.

18) Absolute Battery Connector  
 In the absolute specification, the connector is connected with the absolute battery.

19) Absolute Battery Holder (enclosed in the absolute specification)  
 This is the holder of the absolute battery.

## ■ About SCON-LC Type ■

LC Type is equipped with a built-in PLC feature, and is capable to control SCON with ladder programs instead of the host PLC if the programs are in small scale.



- PIO Type

Each signal of PIO is general input and output. Use it with connecting to internal relay, which each IO pattern is assigned to, with the ladder program if necessary.

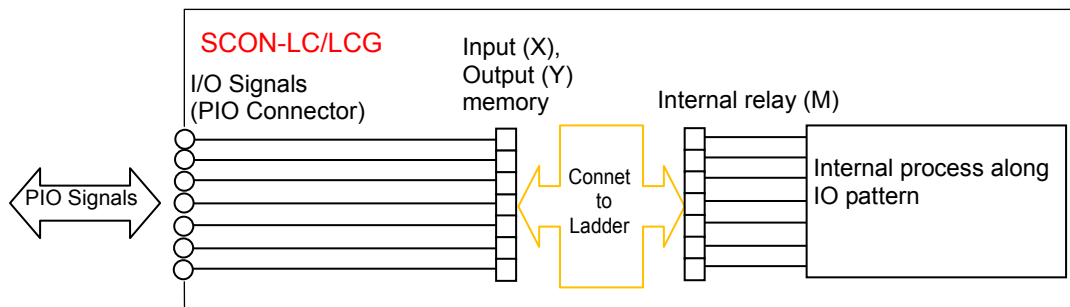

- Fieldbus Type

Each bit in fieldbus communication is general input and output. Use it with connecting to internal relay, which each IO pattern is assigned to, with the ladder program if necessary.

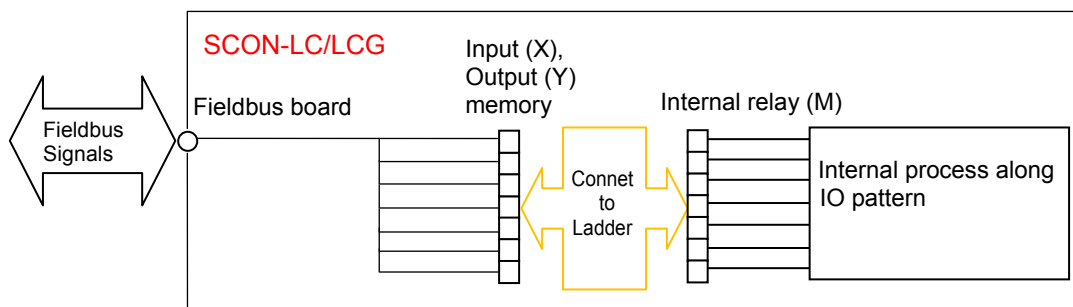

For fieldbus communication, the data volume transferred in one time of communication is restricted.

For CC-Link (1 station 1 time : Remote device station)			
Master	SCON	Master	SCON
RX00~0F	Not to Use	RY00~0F	Not to Use
RX10~1F	Not to Use	RY10~1F	Not to Use
RWr0	Y000~00F	RWw0	X000~00F
RWr1	Y010~01F	RWw1	X010~01F
RWr2	Y020~02F	RWw2	X020~02F
RWr3	Y030~03F	RWw3	X030~03F

For those other than CC-Link (Input 8 bytes, output 8 bytes)			
PLC (Word)	SCON	PLC (Word)	SCON
Input 0	Y000~00F	Output 0	X000~00F
Input 1	Y010~01F	Output 1	X010~01F
Input 2	Y020~02F	Output 2	X020~02F
Input 3	Y030~03F	Output 3	X030~03F

●Operation Pattern (Assignment)

1) The operation pattern is to be set in Parameter No. 84 “Fieldbus Operation Mode”.

Parameter No.84 Setting	Operation Pattern
0	Remote I/O mode
1	Full Functional Mode

The set operation patterns are assigned to the internal relay (input signals to M2048 to 2063, output signals to M2304 to M2319). Figure below shows an example for remote I/O mode (occupied 2 bytes).

☆Example of SCON input side Assignment

	b15	b14	b13	b12	b11	b10	b9	b8	b7	b6	b5	b4	b3	b2	b1	b0
Control Signal	M2319	M2318	M2317	M2316	M2315	M2314	M2313	M2312	M2311	M2310	M2309	M2308	M2307	M2306	M2305	M2304
Control Signal Name	SON	RES	HOME	RMOD	BKRL	CLBR	FPST	ENMV	PHOM	PSTR	PC32	PC16	PC8	PC4	PC2	PC1

☆Example of SCON output side Assignment

Status Signal	M2063	M2062	M2061	M2060	M2059	M2058	M2057	M2056	M2055	M2054	M2053	M2052	M2051	M2050	M2049	M2048
Status Signal Name	*ALML	*ALM	SV	HEND	RMDS	CEND	JDNG	JDOK	MPHM	PSTP	PRSS	SERC	APRC	PORG	PRUN	PCMP

 Caution : It is not applicable for pulse train control.

**Understand the features of SCON with this manual before creating a ladder program.  
[Refer to ME0329 LC Ladder Programming manual]**

## ■ Actuator Axes ■

---

Refer to the pictures below for the actuator axes that can be controlled.

0 defines the home position.

\* The home position cannot be set at the end that the rod is extended (home reversed type).

Rod Type

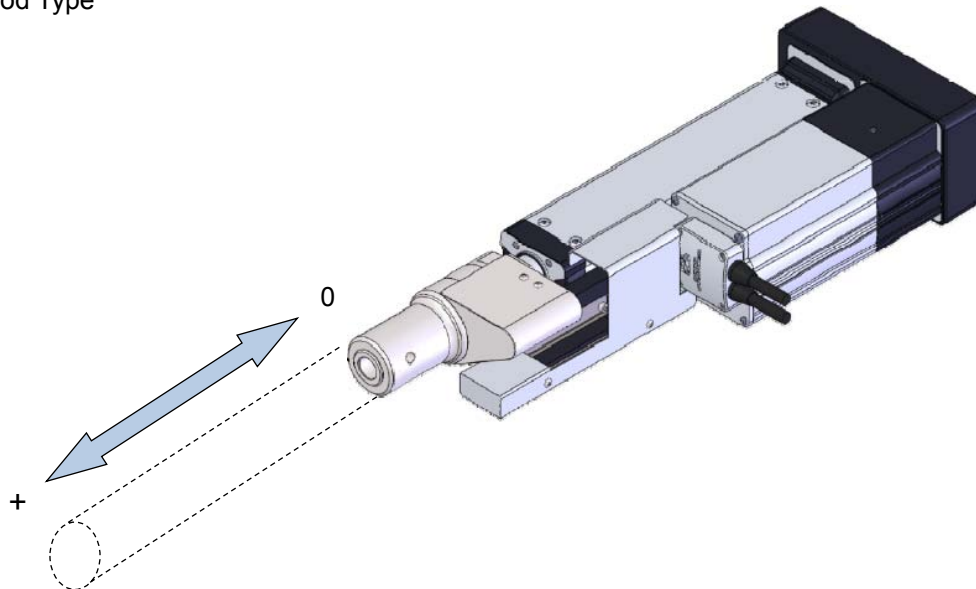













## Chapter 1 Specifications Check

### 1.1 Product Check

#### 1.1.1 Parts

This product is comprised of the following parts if it is of standard configuration.  
If you find any fault in the contained model or any missing parts, contact us or our distributor.

No.	Part Name	Model	Remarks
1	Controller	Refer to "How to read the model plate", "How to read the model".	
Accessories			
2	I/O Flat Cable	CB-PAC-PIO□□□ 	□□ shows the cable length (Example) □□ : 020 = 2 [m]
3	Plug for Multi-Function Connector	Plug : 10114-3000PE (Supplier : 3M) Shell : 10314-52F0-008 (Supplier : 3M) 	Applicable Cable Size 0.2mm <sup>2</sup> (AWG24)
4	System I/O Connector (For ~ 750W Type)	FMC1.5/4-ST-3.5 (Supplier : Phoenix Contact) 	Applicable Cable Size 1.25 to 0.5mm <sup>2</sup> (AWG16 to 20)
	System I/O Connector (For 3000W ~ Type)	FMC1.5/6-ST-3.5 (Supplier : Phoenix Contact) 	
5	Brake Power Supply Connector	MC1.5/2-ST-3.5 (Supplier : Phoenix Contact) 	Applicable Cable Size 1.25 to 0.5mm <sup>2</sup> (AWG16 to 20)
6	AC Power Supply Connector (For ~ 750W Type)	MSTB2.5/6-STF-5.08 (Supplier : Phoenix Contact) 	Applicable Cable Size Control: 0.75mm <sup>2</sup> (AWG18) Motor: 2.0mm <sup>2</sup> (AWG14)
	AC Power Supply Connector (For 3000W ~ Type)	PC5/6-STF-7.62 (Supplier : Phoenix Contact) 	
7	External Regenerative Resistor Unit Connecting Connector (For 3000W ~ Type)	GIC2, 5/2-STF-7.62 (Supplier : Phoenix Contact) 	Applicable Cable Size 0.75mm <sup>2</sup> (AWG18)
8	Absolute Battery	AB-5 	Enclosed for Absolute Type

No.	Part Name	Model	Remarks
9	Dummy Plug	DP-5 	Enclosed for SCON-CGB/LCG
10	Safety Guide		Shown in the figure is an image.
11	First Step Guide		Shown in the figure is an image.
12	Instruction Manual (DVD)		Shown in the figure is an image.

### 1.1.2 Teaching Tool

A teaching tool such as PC software is necessary when performing the setup for position setting, parameter setting, etc. that can only be done on the teaching tool. Please prepare either of the following teaching tools.

No.	Part Name	Model
1	PC Software (Includes RS232C Adapter + Peripheral Communication Cable)	RCM-101-MW
2	PC Software (Includes USB Adapter + USB Cable + Peripheral Communication Cable)	RCM-101-USB
3	Touch Panel Teaching (Standard / with Deadman Switch)	TB-02/TB-02D
4	Data Setter TB-03 (Wired Link)	TB-03

### 1.1.3 Instruction Manuals Related to this Product, which are Contained in the Instruction Manual (DVD)

No.	Name	Manual No.
1	SCON-CB-F/CGB-F/LC-F/LCG-F Servo Press Function Instruction Manual	ME0345
2	PC Software RCM-101-MW/ RCM-101-USB Instruction Manual	ME0155
3	Touch Panel Teaching TB-02/02D Applicable for Position Controller, ELECYLINDER Instruction Manual	ME0355
4	Data Setter TB-03 Position Controller, ELECYLINDER Wired Link Instruction Manual	ME0376
5	DeviceNet Instruction Manual	ME0256
6	CC-Link Instruction Manual	ME0254
7	PROFIBUS-DP Instruction Manual	ME0258
8	CompoNet Instruction Manual	ME0220
9	MECHATROLINK-I/II Instruction Manual	ME0221
10	EtherCAT Instruction Manual	ME0273
11	EtherNet/IP Instruction Manual	ME0278
12	PROFINET IO Instruction Manual	ME0333
13	Instruction Manual for the Serial Communication [for Modbus]	ME0162
14	LC Ladder Programming Manual	ME0329
15	LC Ladder Edit Software Manual	ME0330

### 1.1.4 How to Read the Model Plate

Model	→	MODEL : SCON-CB-200IF-NP-5-2
Serial Number	→	SERIALNo. : 800056144 L11
		INPUT : 1 $\phi$ , 100-115V, 50/60Hz, 1.8A
		OUTPUT : 3 $\phi$ , 0-90V, 0-333Hz, 1.10A

## 1.1.5 How to Read the Model

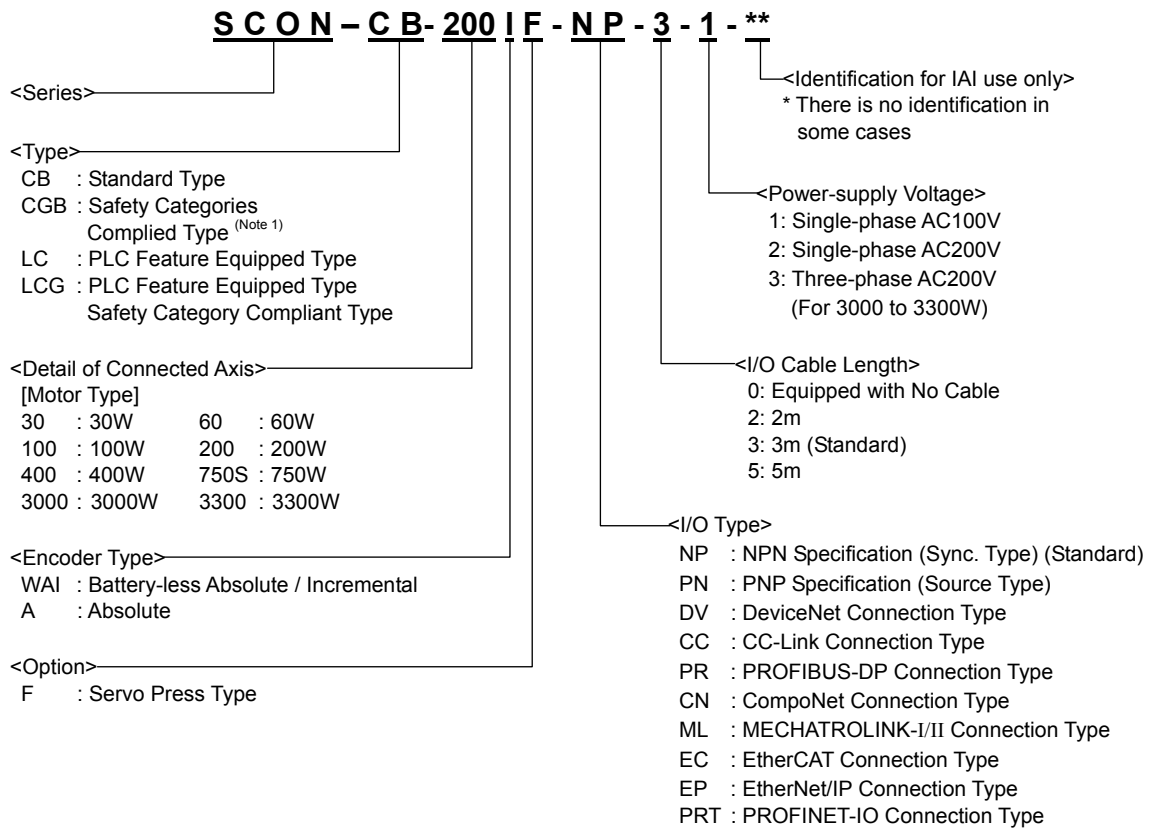

Note 1: There is only safety categories applicable type in the lineup for those types for 3000W and above.



## 1.2 List of Basic Specifications

### 1.2.1 Specification List

Item		SCON-CB-F/CGB-F		
		Less than 400W	400 to 750W	3000W or more
Applicable Motor Capacity		30W to 399W	400W to 750W	3000W to 3300W
Power-supply Voltage		Single-phase AC100 to 115V Single-phase AC200 to 230V (Fluctuation of power supply $\pm 10\%$ or less)	Single-phase AC200 to 230V (Fluctuation of power supply $\pm 10\%$ or less)	Three Phase AC200 to 230V (Fluctuation of power supply $\pm 10\%$ or less)
Rush Current	Power-supply Voltage AC100V	30A (Control side) <sup>(Note 1)</sup> , 80A (Drive side) <sup>(Note 1)</sup>	30A (Control side) <sup>(Note 1)</sup> , 80A (Drive side) <sup>(Note 1)</sup>	40A (Control side), 40A (Drive side)
	Power-supply Voltage AC200V			
Leakage Current <sup>(Note 2)</sup> (Primary side when noise filter is connected to power supply line)		3.0mA		3.5mA
Load Capacity, Heating Value		Refer to the Item for the Power Capacity and Heating Value.		
Heat Generation		Refer to the Item for the Power Capacity and Heating Value.		
Power Supply Frequency		50 / 60Hz		
PIO Power Supply <sup>(Note 3)</sup>		DC24V $\pm 10\%$		
Power Supply for Electromagnetic Brake (for Actuator equipped with Brake)		DC24V $\pm 10\%$ 1A (MAX.) (Supplied from external equipment)		DC24V $\pm 10\%$ 0.1A (MAX.) (Supplied from external equipment) Supply of 1.5A is necessary separately also for the actuator.
Transient Power Cutoff Durability		20ms (50Hz), 16ms (60Hz)		
Motor Control System		Sinusoidal Waveform PWM vector current control		
Corresponding Encoder		Incremental serial encoder Absolute serial encoder		
Actuator Cable Length		MAX. 20m		
SIO Connector	Serial Communication Interface 1	· For connection of Teaching Tool, and connection of Link RS485: 1CH...Modbus Protocol Based on RTU/ASCII Speed: 9.6 to 230.4Kbps		
External Interface (Multi-Function Connector)	Serial Communication Interface 2	· For display connection RS485: 1CH...Modbus Protocol Based on RTU/ASCII Speed: 9.6 to 230.4Kbps		
	Feedback Pulse	Differential system (Line Driver System): MAX. 2.5Mpps Open Collector System: MAX. 500Kpps (JM-08 when option was used))		
	Analog Output	1 system (Load data) 4 to 20mA current output ( $\pm 1\%$ ) Load resistance 10 to 600 $\Omega$		
SCON-CB/CGB	External Interface	PIO Type	24V DC general-purposed signal I/O (Selection of NPN/PNP) ... Input 16 points max., output 16 points max. Insulation with Photocoupler	
		Fieldbus Type	DeviceNet, CC-Link, PROFIBUS, CompoNet, MECHATROLINK- I / II, EtherCAT, EtherNet/IP, PROFINET IO	
	Data Retention Memory	Saves position data and parameters to non-volatile memory (No limitation in number of writing.)		
Cable Length	PIO	MAX. 10m		
	RS485	Total Cable Length 100m or less		
	Fieldbus	Depends on each fieldbus specifications		
Data Setting and Input		PC software		
Operation Mode (Total 8 Modes)		1) Speed Control, Position Stop Mode 2) Speed Control, Distance Stop Mode 3) Speed Control, Load Stop Mode 4) Speed Control, Incremental Load Stop Mode 5) Force Control, Position Stop Mode 6) Force Control, Distance Stop Mode 7) Force Control, Load Stop Mode 8) Force Control, Incremental Load Stop Mode		
Number of Program		MAX. 64		
LED Display (allocated on front panel)		PWR (Green) : Controller in normal startup SV (Green) : Servo ON ALM (Orange) : Alarm generated EMG (Red) : In emergency stop condition		
Electromagnetic Brake Compulsory Release Switch (Allocated on Front Panel)		Switchover of NOM (normal) / BK RLS (compulsory release)		
Insulation Resistance (Between secondary – FG)		DC500V 10M $\Omega$ or more		
Insulation Resistance (Between primary – FG)		AC1500V For 1 minute. (Note) Withstand voltage of pressing operation using force sensor loadcell is 50V DC		

Item		SCON-CB-F/CGB-F		
		Less than 400W	400 to 750W	3000W or more
Environment	Surrounding Air Temperature	0 to 40°C		
	Surrounding Humidity	85%RH or less (should be no condensation or freeze)		
	Surrounding Environment	[Refer to 1.6 Installation and Storage Environment]		
	Surrounding Storage Temperature	-20 to 70°C (should be no condensation or freeze)		
	Surrounding Storage Humidity	85%RH or less (should be no condensation or freeze)		
	Vibration Resistance	Frequency: 10 to 57Hz / Amplitude: 0.035mm (continuous), 0.075mm (intermittently) Frequency: 57 to 150Hz / Acceleration: 4.9m/s <sup>2</sup> (continuous), 9.8m/s <sup>2</sup> (continuous) XYZ Each direction Sweep Time: 10min. Number of Sweep Times: 10 times		
	Impact Resistance	Operation: Half Sine Wave Amplitude / Duration: 50m/s <sup>2</sup> (5g) /30ms		
	Altitude	1000m above sea level or less		
	Overvoltage Category	II		
	Pollution Degree	2		
Mass	Approx. 900g	Approx. 1200g	Approx. 2800g	
Cooling Method	Natural air-cooling	Forced Air-Cooling	Forced Air-Cooling	
External Dimensions	58W × 194H × 121D [mm]	72W × 194H × 121D [mm]	92.7W × 300H × 187.7D [mm]	

- Note 1 In-rush current will flow for approximately 20msec after the power is turned on (at 40°C).  
Note that the value of in-rush current differs depending on the impedance of the power supply line.
- Note 2 Leak current varies depending on the capacity of connected motor, cable length and the surrounding environment.  
Measure the leak current at the point where a ground fault circuit interrupter is to be installed when leakage protection is conducted.  
Regarding the leakage breaker, it is necessary to have a clear purpose for selection such as a fire protection or protection of human body.  
Use the harmonic type (for inverter) for a leakage breaker.
- Note 3 It is not necessary to supply power to PIO, SIO Converter without using PIO. In this case, set the parameter No.74 (PIO Power Supply Monitor) to "1" (Invalid). It will generate the error code No. 0CF (I/O 24V Power Supply Error) if the setting is not done.

### 1.2.2 Item for the Power Capacity and Heating Value

Rated Power Capacity = Motor Power Capacity + Control Power Capacity

Peek Max. Power Capacity = Peek Max. Motor Power Capacity + Control Power Capacity

Wattage of Actuator Motor	Motor Power Capacity [VA]	Peek Max. Motor Power Capacity [VA]	Control Power Capacity [VA]	Rated Power Capacity [VA]	Peek Max. Power Capacity [VA]	Heat Generation [W]
30	46	138	48	94	186	31
60	138	414		186	462	33
100	234	702		282	750	35
200	421	1263		469	1311	38
400	920	2760		968	2808	45
750S	1521	4563		1569	4611	58
3000	5657	16970		5705	17018	180
3300	6014	18041		6062	18089	182

### 1.2.3 Selection of Circuit Breaker

For the selection of the circuit breaker, perform it according to the following items.

- 3 times of the rated current flows to the controller during the acceleration/deceleration. Select an interrupter that does not trip with this value of current. If a trip occurs, select an interrupter that possesses the rated current of one grade higher. (Check the operation characteristics curves in the product catalog.)
- Select an interrupter that does not trip with the in-rush current. (Check the operation characteristics curves in the product catalog.)
- Consider the current that enables to cutoff the current even when a short circuit current is flown for the rated cutoff current.

Rated Interrupting Current > Short Circuit Current = Primary Power Capacity / Power Voltage  
Consider margin for the rated current on the circuit breaker.

- Calculation for Motors of up to 750W

Rated Current for Circuit Interrupter >

$(\text{Rated Motor Power Capacity [VA]} + \text{Control Power Capacity [VA]}) / \text{AC Input Voltage} \times \text{Safety Margin (reference 1.2 to 1.4 times)}$

- Calculation for Motors of 3000W and above

Rated Current for Circuit Interrupter >

$(\text{Rated Motor Power Capacity [VA]} + \text{Control Power Capacity [VA]}) / \text{AC Input Voltage} \times \text{Safety Margin (reference 1.2 to 1.4 times)} \div \sqrt{3}$

### 1.2.4 Selection of Leakage Breaker

- Regarding the leakage breaker, it is necessary to have a clear purpose for selection such as a fire protection or protection of human body.
- Leak current varies depending on the capacity of connected motor, cable length and the surrounding environment. Measure the leak current at the point where a ground fault circuit interrupter is to be installed when leakage protection is conducted.
- Use the harmonic type for a leakage breaker.

### 1.3 External Dimensions

#### 1.3.1 SCON-CB/CGB/LC/LCG less than 400W

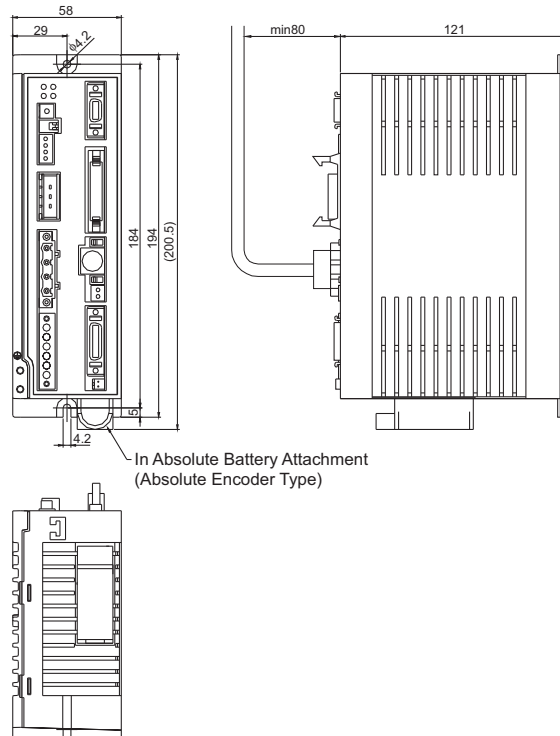

#### 1.3.2 SCON-CB/CGB/LC/LCG 400W to 750W

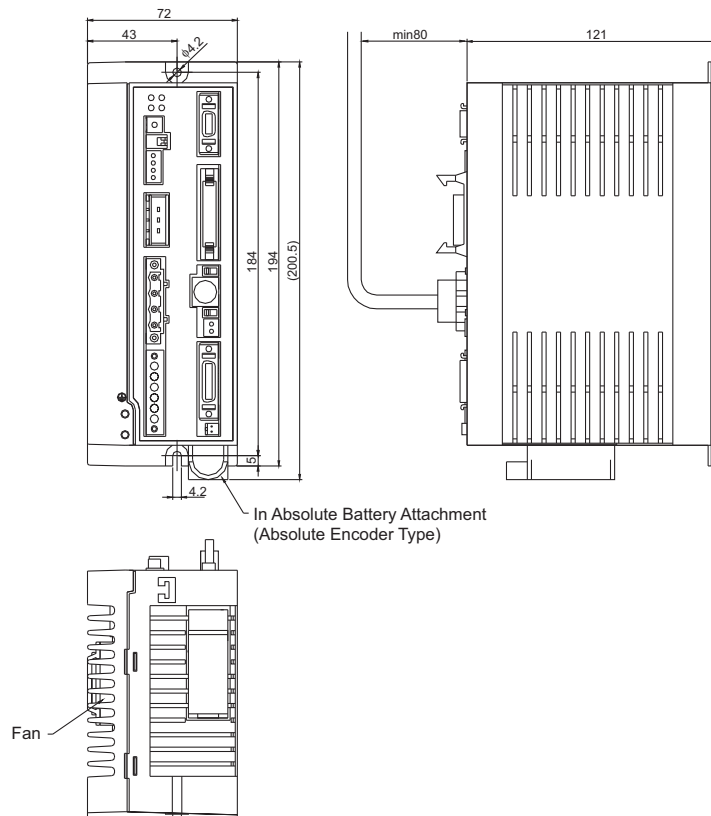

1.3.3 SCON-CB/CGB/LC/LCG 3000W to 3300W

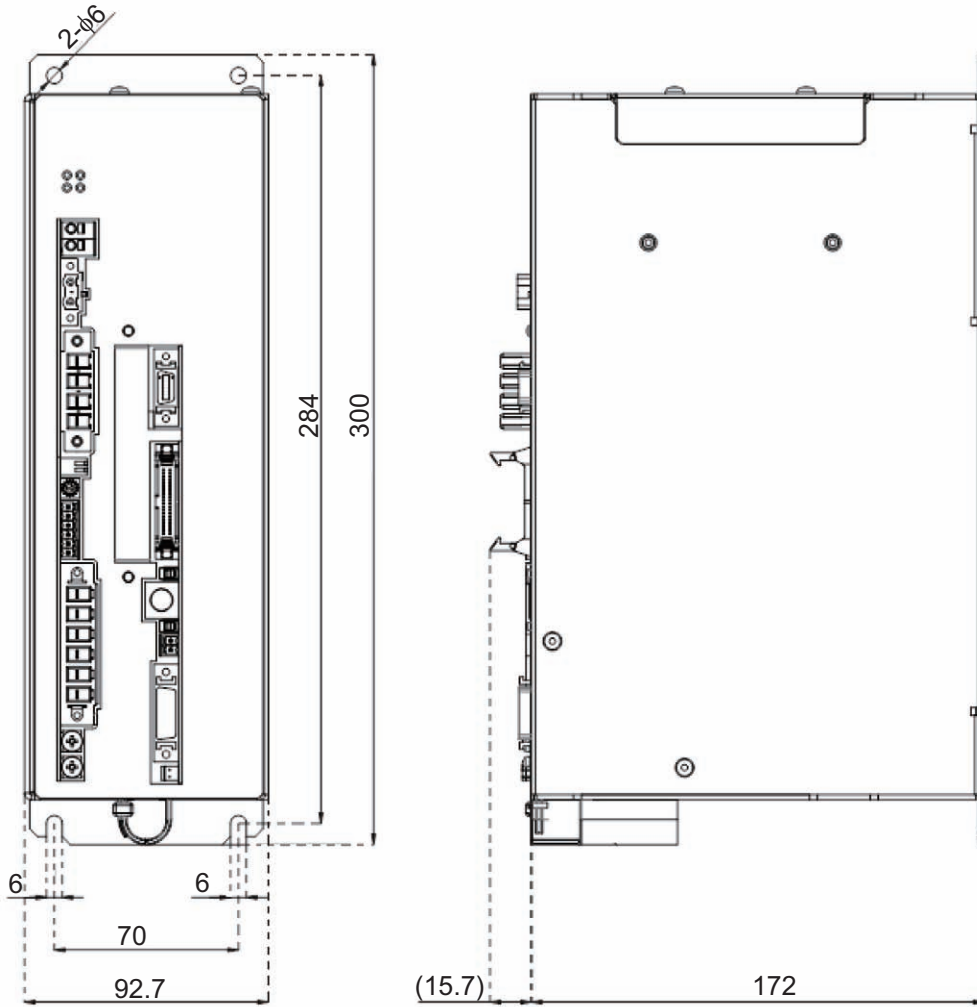

## 1.4 External Interface Specifications

### 1.4.1 Standard Input Output Interface Specification (Multi-Function Connector)

There are 3 types in the external interface mounted in the standard.

- 1) Serial Communication Interface 2 (For display device etc.)
- 2) Analog Output (Load of loadcell)
- 3) Encoder Feedback Pulse Output

#### 1) Serial Communication Interface 2 (SIO2) Type

Serial communication interface 2 is to be assigned to the multi-function connector, it is to be used for connection to a touch panel or display.

Item	Specification
Communication standard	Based on EIA RS485
Baud rate	9600/14400/19200/28800/38400/57600/ 76800/115200/230400bps
Communication system	Half duplex communication
Connection format	1: N Disequilibrium Bus Connection (MAX. 16 units)
Communication cable length	MAX. 100m
Bit length	8 bit
Parity	None
Stop bit	1 bit
Protocol	Modbus (RTU/ASCII: Automatic Identification)

#### ⚠ Caution

- Connect the PC software to serial communication interface 1 (SIO connector).
- When using the PC software and serial communication interface 2 (SIO2) at the same time, use only the query (command) for data readout for SIO2. Using queries for writing or command may cause unexpected operation.

#### 2) Analog Output Type

It outputs the load data as an analog signal from the loadcell.

Item	Specification
Output current	4 to 20mA Output in ratio to the loadcell rated capacity 4mA = -30% 7mA = 0% 17mA = 100% 20mA = 130%
Accuracy <sup>(*)</sup>	±1%FS
Load resistance	10 to 600Ω

\* It is the accuracy for analog output, and does not include loadcell accuracy.

#### 3) Encoder Feedback Pulse Output Type

Item	Specification
Output pulse train	Differential (Line driver Output: 26C32 or equiv.)
Max. pulse frequency	2.5Mpps

### 1.4.2 Input Output Interface Specification dedicated for PIO Type

[1] Signal I/O type dedicated for 24V

(Note) The function of each signal is fixed and cannot be used for general purpose.

Specification	Input Section		Output Section	
	Input Voltage	24V DC $\pm 10\%$	Load Voltage	DC24V
	Input Current	4mA 1circuit	Peak Load Electric Current	50mA/1circuit
	ON/OFF Voltage	ON Voltage MIN. 18V DC OFF Voltage MAX. 6V DC	Leakage Current	MAX.0.1mA/1circuit
Insulation	Insulation with Photocoupler			
NPN				
PNP				
I/O Cable	Refer to 2.1.2 [5] PIO Connector			

NPN Specification

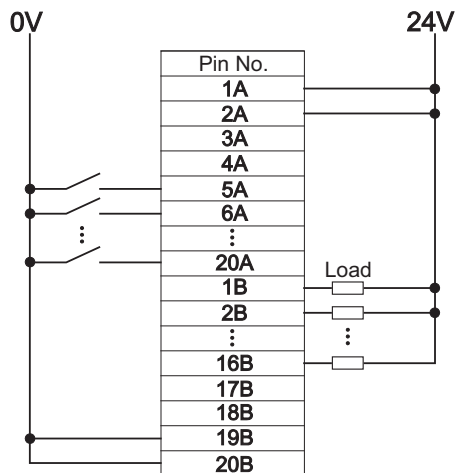

PNP Specification

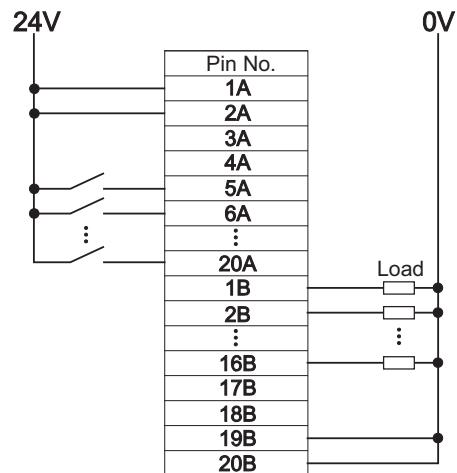

### 1.4.3 Filedbus Type Specifications

#### [1] DeviceNet Specifications

Item	Specification			
Communication Standard	DeviceNet 2.0			
	Group 2 only Server			
	Network-Powered Insulation Node			
Baud Rate	Automatic Tracking to Master			
Communication System	Master-Slave System (polling)			
Number of Occupied Channels	<ul style="list-style-type: none"> <li>• 1CH (Remote I/O mode)</li> <li>• 16CH (Full function support mode)</li> </ul>			
Number of Occupied Nodes	1 Node			
Communication cable Length	Baud Rate	Network Max.Length	Total Branch Cable Length	Max Branch Cable Length
	500kbps	100m	39m	6m
	250kbps	250m	78m	
	125kbps	500m	156m	
Communication Cable	Use a dedicated cable available.			
Connector <sup>(Note1)</sup>	MSTB2.5/5-GF-5.08 AU (Made by Phoenix Contact or equivalent)			
Communication Power Current Consumption	60mA			
Communication Power	24V DC (Supplied from Device Net side.)			

Note1 Cable side Connector is enclosed in standard.  
 Made by Phoenix Contact: MSTB2.5/5-STF-5.08 AUM

#### [2] CC-Link Specifications

Item	Specification		
Communication Standard	CC-Link Ver 1.1		
Station Type	Remote device station (MAX. 4station occupied)		
Baud Rate	10M/5M/2.5M/625K/156kbps		
Communication System	Broadcast Polling System		
Number of Occupied Stations	<ul style="list-style-type: none"> <li>• 1station (Remote I/O mode)</li> <li>• 4station (Full function support mode)</li> </ul>		
Communication Cable Length	Baud Rate	Total Cable length	Cable Type
	10Mbps	100m	Dedicated high performance cable (FANC-SBH) Standard Cable (FANC-SB)
	5Mbps	160m	
	2.5Mbps	400m	
	625kbps	900m	
	156kbps	1200m	
Connector <sup>(Note1)</sup>	MSTB2.5/5-GF-5.08 AU (Made by Phoenix Contact or equivalent)		

Note1 Cable side Connector is enclosed in standard.  
 Made by Phoenix Contact: MSTB2.5/5-STF-5.08 AUM



### [3] PROFIBUS-DP Specifications

Item	Specification		
Baud Rate	Automatic Tracking to Master		
Communication System	Hybrid System (Master-Slave System or Token Passing System)		
Number of Occupied Bytes	<ul style="list-style-type: none"> <li>• 2byte (Remote I/O mode)</li> <li>• 32byte (Full function support mode)</li> </ul>		
Communication Cable Length	Max. Total Network	Baud Rate	Cable Type
	100m	12,000/6,000/3,000kbps	
	200m	1,500kbps	
	400m	500kbps	
	1000m	187.5kbps	
	1200m	9.6/19.2/93.75kbps	
Communication Cable	Twisted pair cable equipped with shield AWG18		
Connector <sup>(Note1)</sup>	9Pin female D-sub connector		
Transmission Path Format	Bus/Tree/Star		

Note1 Prepare a 9Pin male D-sub connector for the cable side connector.

### [4] CompoNet Specifications

Item	Specification
Communication Type	Remote I/O Communication
Baud Rate	Automatic Tracking to Master
Communication Cable Length	Depends on CompoNet specification
Slave Type	Word Mix slave
Number of Occupied Channels	<ul style="list-style-type: none"> <li>• 1CH (Remote I/O mode)</li> <li>• 16CH (Full function support mode)</li> </ul>
Communication Cable <sup>(Note1)</sup>	Round Cable (JIS C3306、VCTF 2cores) Flat cable I (without sheath) Flat cable II (with sheath)
Connector (Controller side)	XW7D-PB4-R (Made by Omron or equivalent)

Note1 Prepare a communication cable separately.

### [5] MECHATROLINK- I / II Specifications

Item	Specification	
Slave Type	Intelligent I/O	
Baud Rate	MECHATROLINK- I	4Mbps
	MECHATROLINK- II	10Mbps
Max. Transmission Distance	50m	
Min. Distance Between Stations	0.5m	
Connecting Number of Slaves	MECHATROLINK- I	15 station
	MECHATROLINK- II	30 station (repeater required for 17stations and more)
Transmission Frequency	1 to 8ms	
Data Length	MECHATROLINK	17/32 byte (* It is applicable only to remote I/O mode)
Communication Cable <sup>(Note1)</sup>	Twisted pair cable equipped with shield (Characteristic impedance 130Ω)	
Connector	Controller Side	DUSB-ARB82-T11A-FA (Made by DDK or equivalent)

Note1 Prepare a communication cable separately.

## [6] EtherNet/IP Specifications

Item	Specification
Baud Rate	10BASE-T/100BASE-T (It is recommended to Auto Negotiation setting)
Communication Cable Length	Depends on EtherNet/IP specification (Distance between hub and each nodes: 100m max.)
Number of Connection	Depends on master unit
Applicable Node Address	0.0.0.0~255.255.255.255
Number of Occupied Bytes	<ul style="list-style-type: none"> <li>• 2byte (Remote I/O mode)</li> <li>• 32byte (Full function support mode)</li> </ul>
Communication Cable <sup>(Note1)</sup>	Category 5 or more (double-shielded cable braided with aluminum tape recommended)
Connector	One RJ45 connector

Note1 Prepare a communication cable separately.

## [7] EtherCAT Specifications

Item	Specification
Physical Layer	100Base-TX (IEEE802.3)
Baud Rate	Automatic Tracking to Master
Communication Cable Length	Depend on EtherCAT® specification (Distance between nodes: 100m max.)
Slave Type	I/O slave
Number of Occupied Bytes	<ul style="list-style-type: none"> <li>• 2byte (Remote I/O mode)</li> <li>• 32byte (Full function support mode)</li> </ul>
Communication Cable <sup>(Note1)</sup>	Category 5e or more (double-shielded cable braided with aluminum tape recommended)
Connector	Two RJ45 connectors (Input×1, Output×1)
Connection	Daisy chain connection only

Note1 Prepare a communication cable separately.

## [8] PROFINET-IO Specifications

Item	Specification
Baud Rate	100Mbps
Communication Cable Length	Distance between each segment: 100m max.
Number of Connection	Depends on master unit
Applicable Node Address	0.0.0.0 to 255.255.255.255
Number of Occupied Bytes	<ul style="list-style-type: none"> <li>• 2byte (Remote I/O mode)</li> <li>• 32byte (Full function support mode)</li> </ul>
Communication Cable <sup>(Note1)</sup>	Category 5 or more (double-shielded cable braided with aluminum tape recommended)
Connector	One RJ45 connector

Note1 Prepare a communication cable separately.

## 1.5 Options

### 1.5.1 Regenerative Unit for Motors of up to 750W

It is a unit to convert the regenerative current generated at motor deceleration into heat. Refer to 2.2.6 Connection of Regenerative Unit for the number of connectable units.

[Model, Accessories]

Item			Accessories
Model	1st unit	Screw affixed standard type	REU-2
		Screw affixed small type	RESU-2
		DIN rail affixed small type	RESUD-2
2nd unit or later	Screw affixed standard type	REU-1	Regenerative resistor unit cable (Model: CB-ST-REU010) 1m enclosed
	Screw affixed small type	RESU-1	
	DIN rail affixed small type	RESUD-1	

[Specifications]

	REU-1, REU-2	RESU-1, RESU-2	RESUD-1, RESUD-2
Main Unit Dimension [mm]	W34×H195×D126	W34×H154×D106.5	W34×H158×D115
Main Unit Mass	Approx. 0.9kg	Approx. 0.4kg	
Built-in Regenerative Resistor	235Ω 80W		

[External Dimensions]

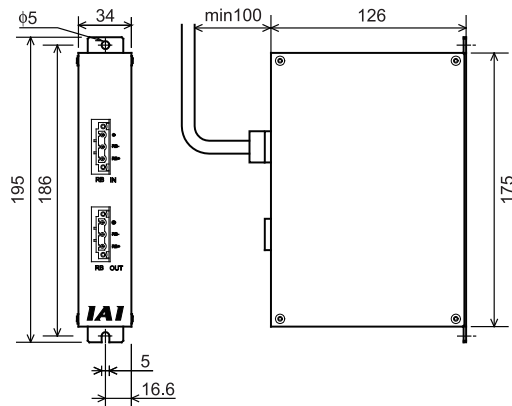

REU-1, REU-2 (Screw affixed standard type)

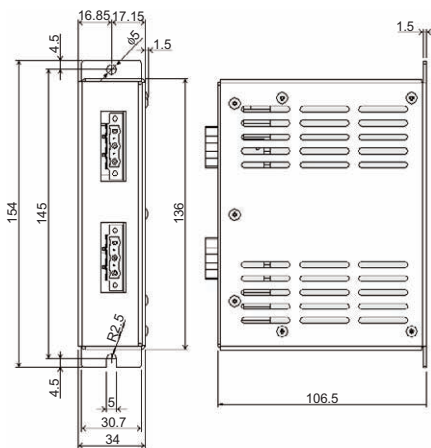

RESU-1, RESU-2 (Screw affixed small type)

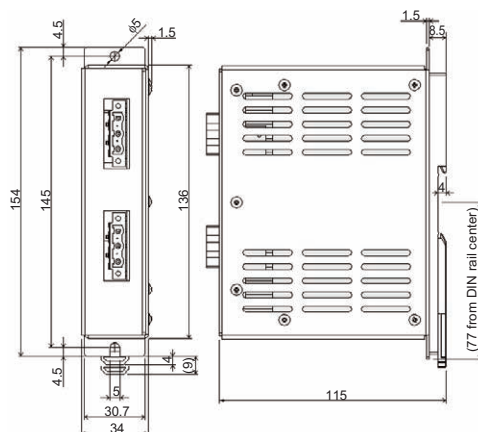

RESUD-1, RESUD-2 (DIN rail affixed small type)

## 1.5.2 Regenerative Unit for Motors of 3000W and above

It is a unit to convert the regenerative current generated at motor deceleration into heat.  
Refer to 2.4.6 Connection of Regenerative Unit for the number of connectable units.

### [Model, Accessories]

Model	Accessories
RESU-35T	None

### [Specifications]

Item	Specification	
Main Unit Dimension [mm]	W45×H300×D197	
Main Unit Mass	Approx. 1.8kg	
Built-in Regenerative Resistor	30Ω 450W	
Built-in Temp. Sensor	Operation Temp.	130°C ±5°C
	Contact Format	Contact b
	Contact Open-Close Capacity	DC30V (MAX) 200mA (MAX)

### [External Dimensions]

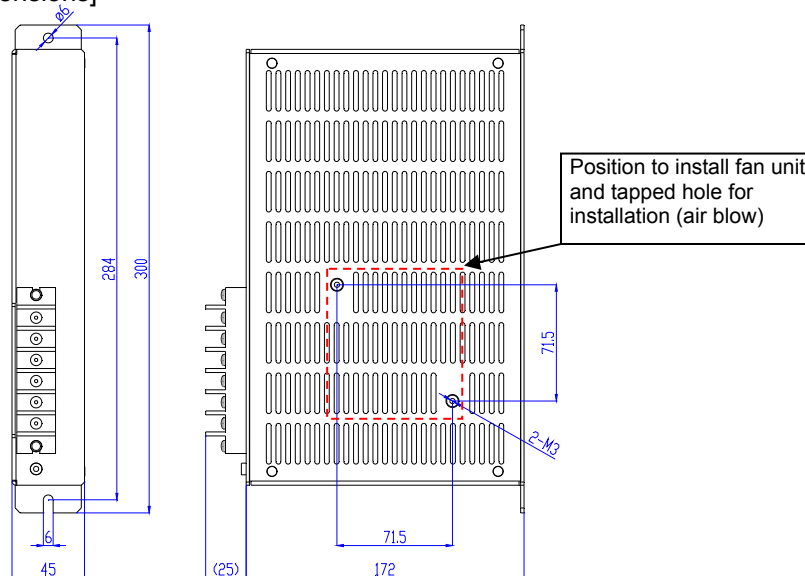

### ⚠ Caution :

- The temperature for the external regenerative resistor units get high.
- Do not attempt to install the unit near a flammable object.
- Do not attempt to touch them.
- It is recommended that the cables to be used should possess high performance in the heat resistance. Also, pay attention to have the cables not to touch the external regenerative resistor units.
- The unit is equipped with a built-in temperature sensor. Establish the circuit constructed to cut off the power source when the temperature sensor is in operation.
- Attach a fan unit if necessary. There are tapped holes equipped so a fan unit sized 80mm □80mm can be installed.

### [Reference] Specifications for External Fan Unit

Item	Specification
Size	□80mm
Air Blow Volume	0.45m <sup>3</sup> /min. or more
Direction of Air Blow	Blow air against resistors
Installation	M4 Screw length: Thickness of fan unit + 6mm max.

### 1.5.3 Brake Box: RCB-110-RA13-0

Brakes for two axes can be controlled with one brake box. This is necessary when connecting an actuator with indication to connect a brake box.

[Specifications]

Item	Specification
Main Unit Dimension	162×94×65.5mm
Power supply Voltage, Current	DC24V±10% 1A
Connection Cable	Encoder Cable (Model CB-RCS2-PLA010) 1m
Number of Controlled Axes	2

[External Dimensions]

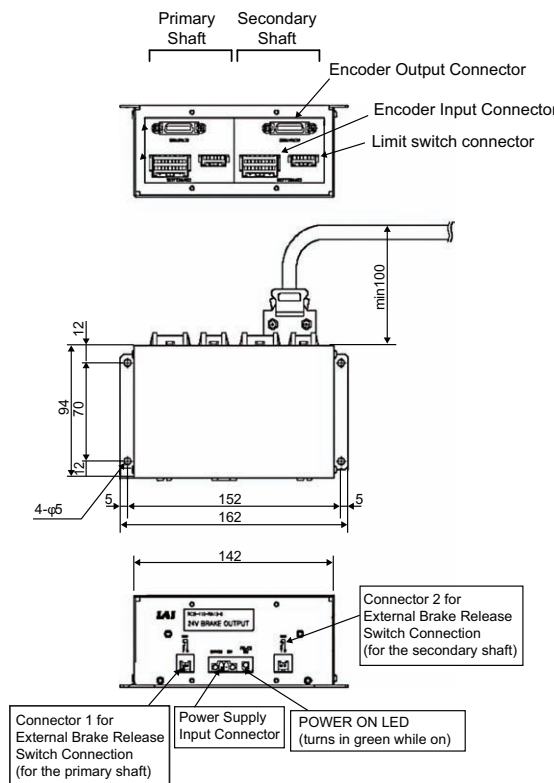

[24V Power Supply Connector]

Connector on Cable Side (Enclosed in standard package)	MC1.5/2-STF-3.5 (Phoenix Contact)		
Applicable Cable	AWG28 to 16		
Terminal Assignments	Pin No.	Signal	Explanation
	1	0V	Power Supply Grounding for Terminal Brake Excitation
	2	24VIN	For Brake Excitation and 24V Power Supply

[Brake Release Switch Connector for the Current 1, 2]

Short circuit of pin No. 1 and 2 of this connector releases the brake compulsorily. Same as the brake release switch ON controller unit, it is possible to release the brake. Do not keep the compulsory release condition while in automatic operation.

Connected Equipment	Brake Release Switch		
Connector on Cable Side (Please prepare separately)	XAP-02V-1 (Contact BXA-001T-P0.6) (J. S. T. Mfg. Co., Ltd.)		
Switch Rating	DC30V Min. current 1.5mA		
Terminal Assignment	Pin No.	Signal	Explanation
	1	BKMRL	Brake Release Switch Input
	2	COM	Power Supply Output for Brake Release Switch Input

### 1.5.4 Load Cell

The pressing operation using force sensor.

[Specifications]

Item	Specification					
Loadcell System	Strain Gauge					
Rated Capacity [N]	200	600	2000	6000	20000	50000
Allowable Oberload <sup>(Note 1)</sup> [%R.C*]	200		200	200	200	200
Lordcell Accuracy [%R.C*]	±1.0		±1.0	±1.0		
Ambient temperature range [°C]	0 to 40					
Dielectric strength voltage [V]	DC50					

\* R.C: Rated Capacity

Note 1 An alarm will be generated when exceeding 125%R.C of pressing or 25%R.C of pulling.

[Example of Attachment]



Check the Instruction Manual for details of how to attach and the dimensions.

**⚠ Caution :** Do not give excess shock (caused by dropping it, etc.) to the loadcell. Failure to follow it may cause the loadcell to be damaged.

### 1.5.5 Pulse Converter: JM-08

It converts the differential system feedback pulse into the open collector specification. Use this converter if the host controller sends pulses input in the open collector mode.

[Specifications]

Item	Specification
Input Power Supply	DC24V±10% (MAX. 50mA)
Input Pulse	Differential output equivalent to 26C32 (MAX. 10mA)
Input Frequency	500KHz or less
Output Pulse	24V DC open collector (Collector current MAX. 25mA)
Mass	10g or less (excluding cable connector)
Accessories	37104-3122-000FL (e-CON Connector) 2 Units Applicable wire AWGNo.24 to 26 (Less than 0.14 to 0.3mm <sup>2</sup> , finished O.D. φ1.0 to 1.2mm)

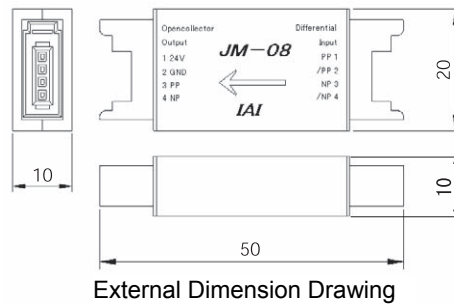

- ⚠ Caution :
- 1) Use the pulse converter in the surrounding temperature range between 0°C to 40°C.
  - 2) The temperature increase of about 30°C occurs during operation. Accordingly, neither install several pulse converters in close contact nor install them within a duct. Do not install the pulse converter near other heating devices.
  - 3) If more than one pulse converter are installed, set a pulse converter apart from another by 10mm or more.

## 1.6 Installation and Storage Environment

This product is capable for use in the environment of pollution degree 2\*<sup>1</sup> or equivalent.

\*1 Pollution Degree 2 : Environment that may cause non-conductive pollution or transient conductive pollution by frost (IEC60664-1)

### [1] Installation Environment

Do not use this product in the following environment.

- Location where the surrounding air temperature exceeds the range of 0 to 40°C
- Location where condensation occurs due to abrupt temperature changes
- Location where relative humidity exceeds 85%RH
- Location exposed to corrosive gases or combustible gases
- Location exposed to significant amount of dust, salt or iron powder
- Location subject to direct vibration or impact
- Location exposed to direct sunlight
- Location where the product may come in contact with water, oil or chemical droplets
- Environment that blocks the air vent [Refer to 1.7 Noise Elimination and Mounting Method]

When using the product in any of the locations specified below, provide a sufficient shield.

- Location subject to electrostatic noise
- Location where high electrical or magnetic field is present
- Location with the mains or power lines passing nearby

### [2] Storage and Preservation Environment

- Storage and preservation environment follows the installation environment. Especially in a long-term storage, consider to avoid condensation of surrounding air. Unless specially specified, moisture absorbency protection is not included in the package when the machine is delivered. In the case that the machine is to be stored in an environment where dew condensation is anticipated, take the condensation preventive measures from outside of the entire package, or directly after opening the package.



## 1.7 Noise Elimination and Mounting Method

### (1) Noise Elimination Grounding (Frame Ground)

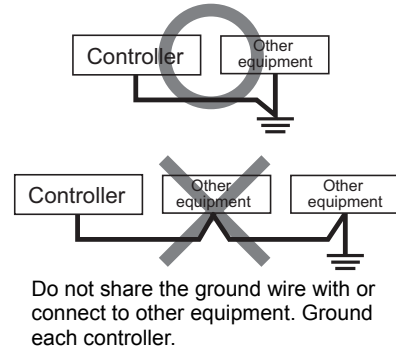
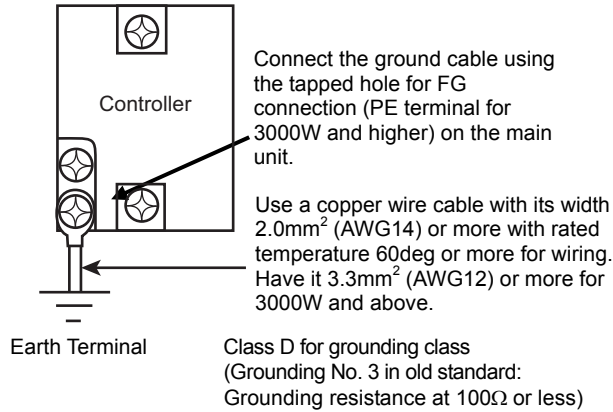

### (2) Precautions Regarding Wiring Method

- 1) Wire is to be twisted for the power supply.
- 2) Separate the signal and encoder lines from the power supply and power lines.
- 3) Set the tightening torque for the FG connection terminal screw to 1.0 to 1.2N•m.

### (3) Noise Sources and Elimination

Carry out noise elimination measures for electrical devices on the same power path and in the same equipment. The following are examples of measures to eliminate noise sources.

- 1) AC solenoid valves, magnet switches and relays  
[Measure] Install a Surge absorber parallel with the coil.
- 2) DC solenoid valves, magnet switches and relays  
[Measure] Mount the windings and diodes in parallel.  
Select a diode built-in type for the DC relay.

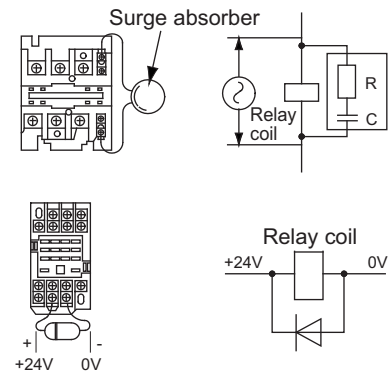

(4) Heat Radiation and Installation

Design and Build the system considering the size of the controller box, location of the controller and cooling factors to keep the surrounding temperature around the controller below 40°C. Also, set up a fan to keep the ambient temperature even.

- For Controller for Motors of up to 750W

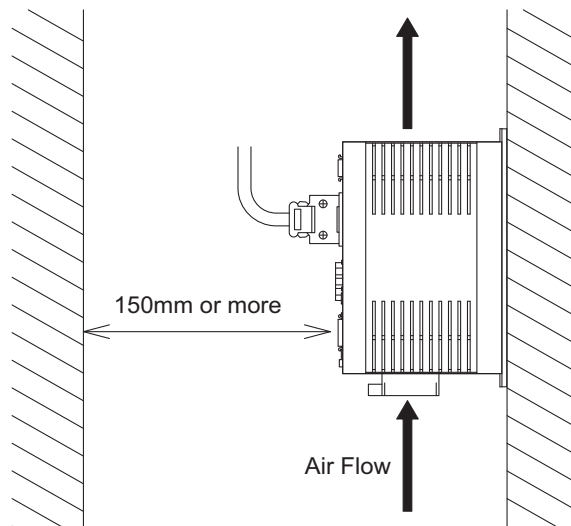
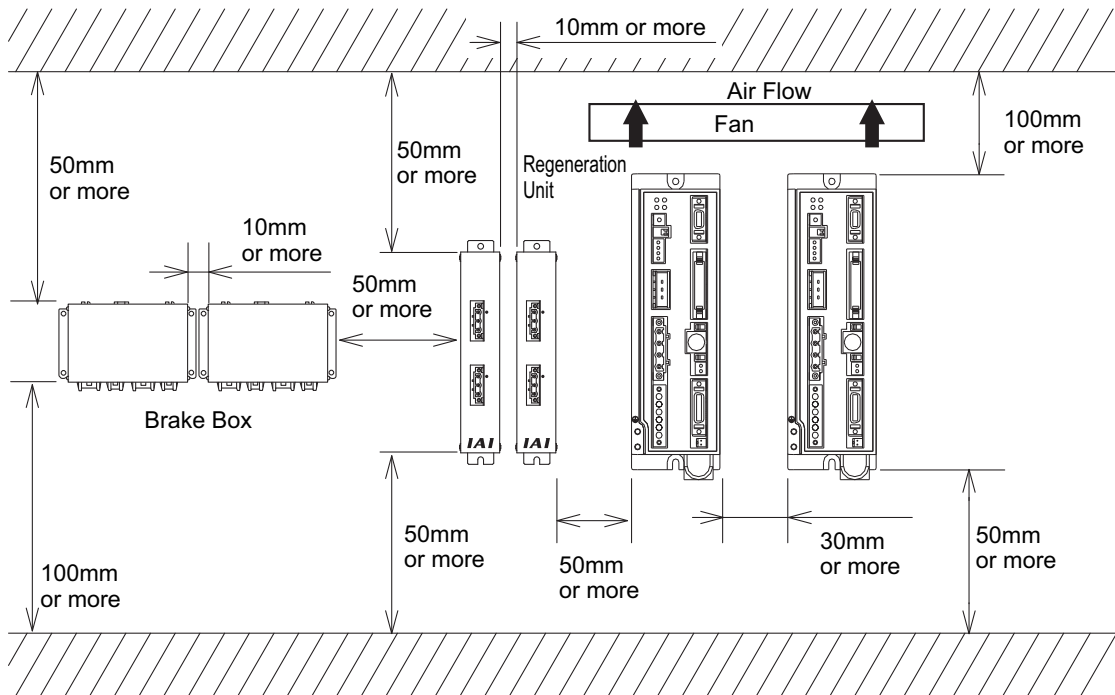

- For Controller for Motors of 3000W and above

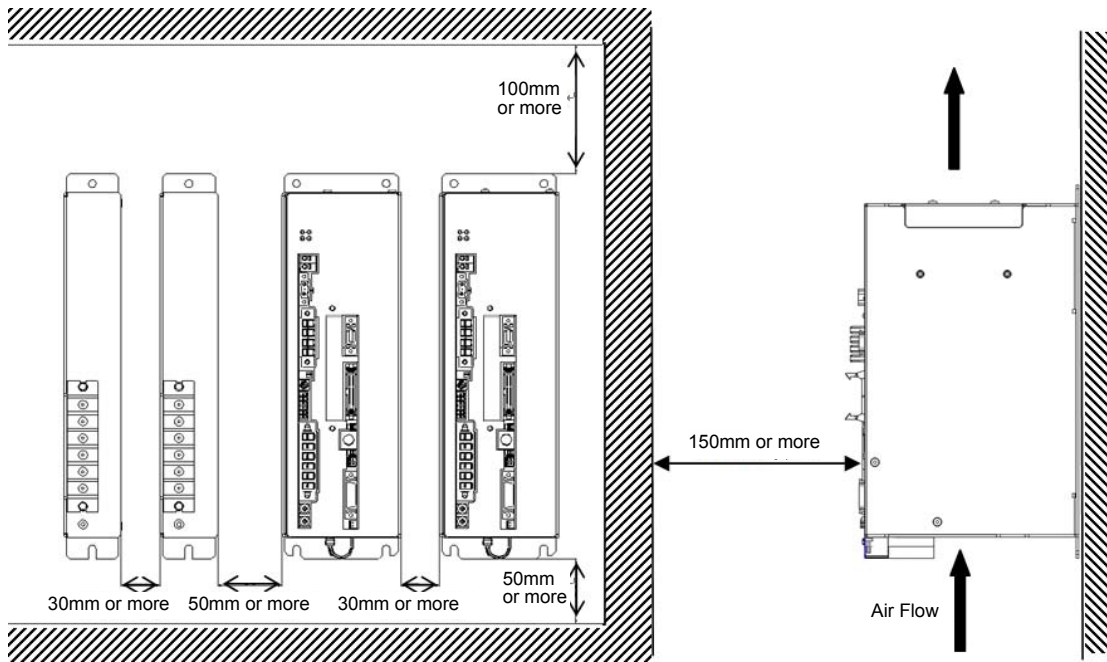



## Chapter 2 Wiring

The servo press type SCON can select PIO or fieldbus\* as the control method of the host controller.

\* Select when purchasing. Cannot be changed after purchased.

Applicable fieldbus: CC-Link, DeviceNet, PROFIBUS-DP, CompoNet, MECHATROLINK- I / II , EtherCAT, EtherNet/IP, PROFINET-IO

There is no actual difference in cable wiring between CB/CGB Types and LC/LCG Types. The difference is only that each signal is dedicated or general-purposed. CB/CGB Types operate with turning on/off of the dedicated signals or direct numeric indication while LC/LCG Types process (control) the turning on/off of the general-purposed signals with ladder programs.

[Refer to About SCON-LC Type in front of Chapter 1 for detail]

### 2.1 Servo Press Controller for Motors of up to 750W (PIO Control)

\* Refer in Section 2.3 and 2.4 for the controller for motors of 3000W and above.

#### 2.1.1 Wiring Diagram (Connection of Devices)

##### [1] Basic Wiring Diagram

Regenerative Resistor Unit (RESU-2 : option)  
Required depending on usage condition

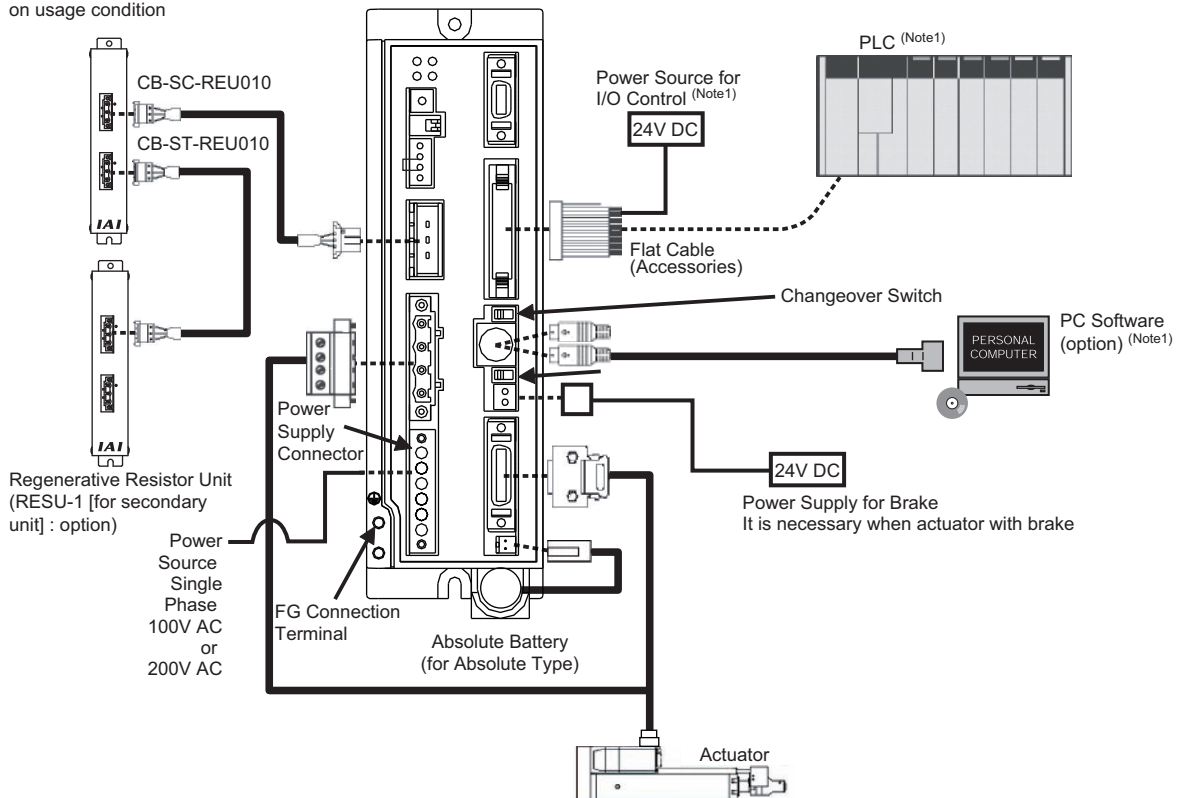

Note 1 Please prepare separately.

**⚠ Caution :** Make sure to turn the power to the controller OFF when inserting or removing the connector that connects the PC software or touch panel teaching to the controller. Inserting or removing the connector while the power is turned ON causes a controller failure.

2.1.2 Wiring

[1] Main Power Circuit

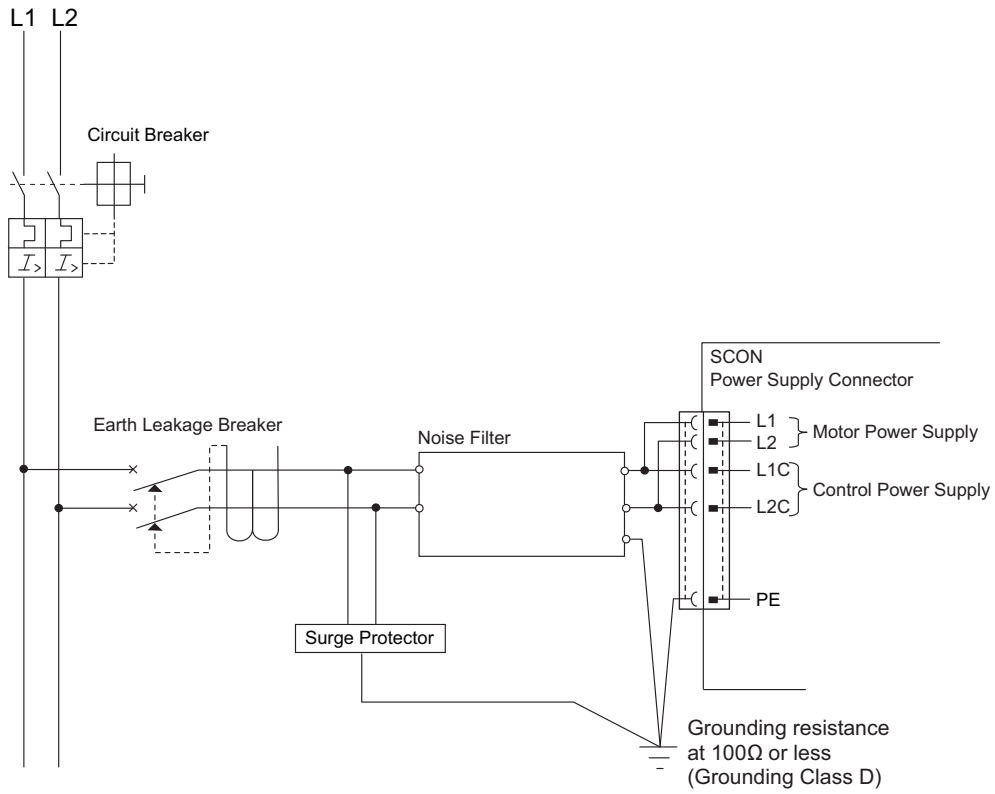

(Note) The power voltage of the controller (100V AC or 200V AC) cannot be changed.

[2] Brake Power Supply Circuit

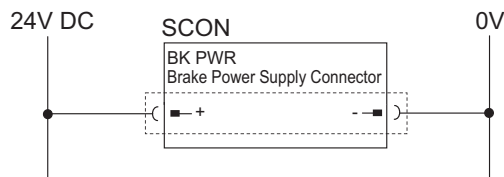

(Note) Supply 24V DC if the used actuator is equipped with a brake.

[3] Actuator Emergency Stop Circuit (System I/O connector)

As an example of a circuit, cases of 2) or 3) for CGB/LCG type.

★Reference: Operate the actuator for try (Note: It is not emergency stop)

- 1) Operate actuator with the equipment and emergency stop of teaching tool input (EMG-) activated
- 2) Stop supplying external motor power at emergency stop input
- 3) Shut off the motor power externally by inputting the emergency stop with using two units of controllers or more.

★Reference: Operate the actuator with the PC software for try

● Example of a Circuit

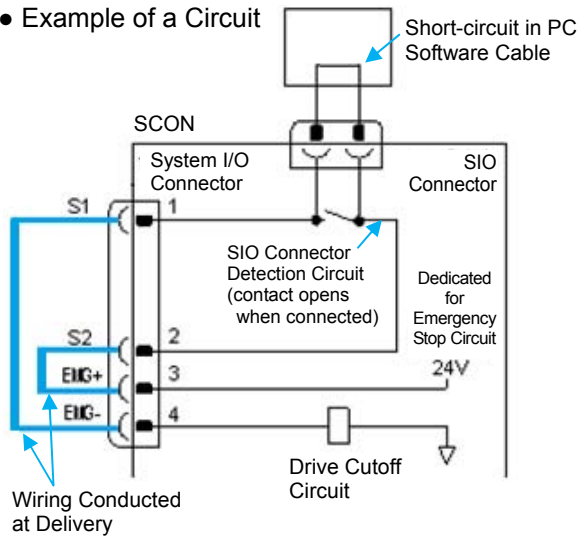

● Image of Wiring

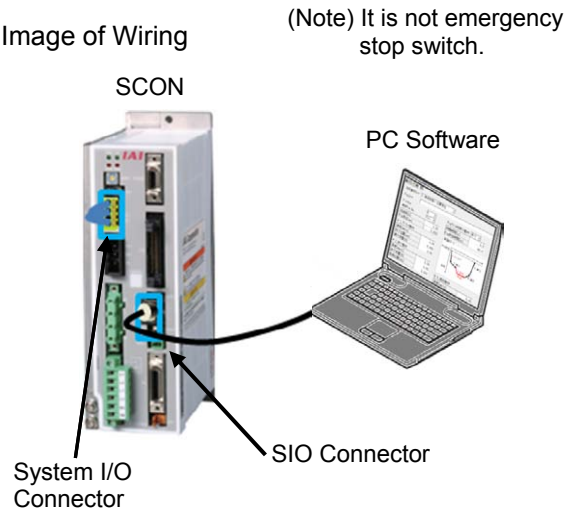

1) Operate actuator with the equipment and emergency stop of teaching tool input (EMG-) activated

● Example of a Circuit

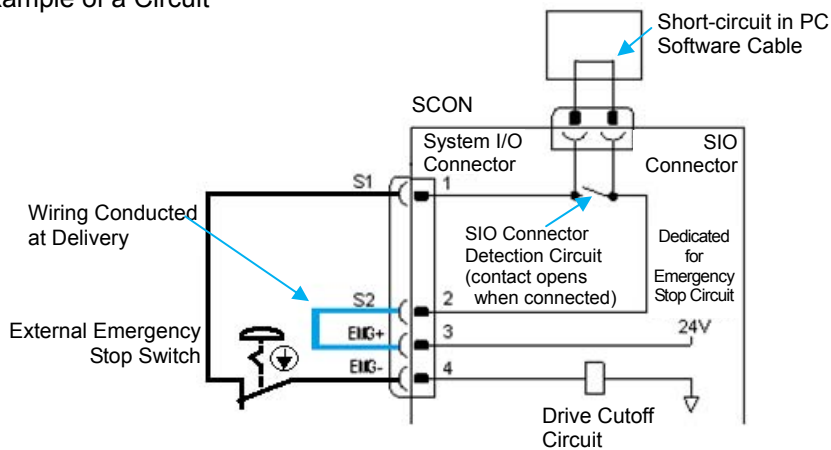

● Image of Wiring

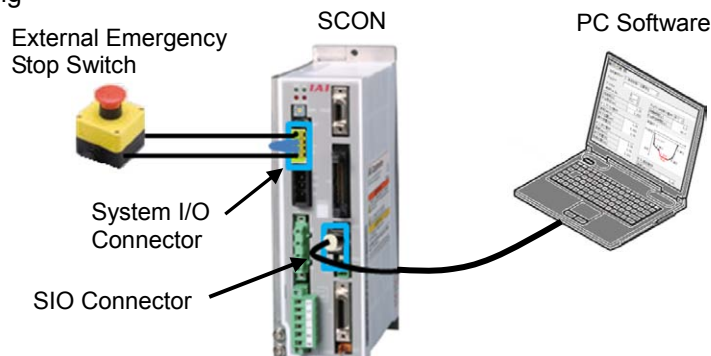

2) Stop supplying external motor power at emergency stop input

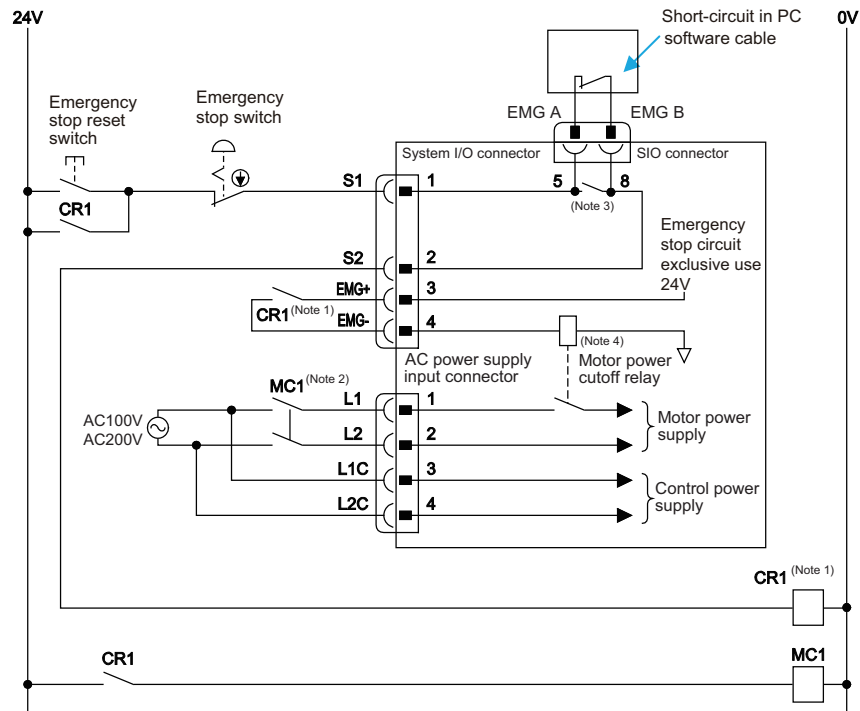

- Note 1 The rating for the emergency stop signal (EMG-) to turn ON/OFF at contact CR1 is 24V DC and 10mA or less.
- Note 2 Connect such as a connector to L1/L2 terminals when cutting off the motor power source externally.  
(CB/LC type are equipped with the drive cutoff relay mounted inside the controller.)
- Note 3 CGB/LCG type are not equipped with a relay to enable to automatically identify a teaching tool was inserted and switch the wiring layout. (The system I/O connector does not get short-circuited between S1 and S2 terminals even if a teaching tool is removed.) The controller on CB/LC type automatically identifies that a teaching tool was inserted. (Short-circuit is made between S1 and S2 terminals inside the controller once connection is detected.)
- Note 4 Since there is no motor power cutoff relay in CGB/LCG type, make sure to establish a cutoff relay externally.



3) Shut off the motor power externally by inputting the emergency stop with using two units of controllers or more.

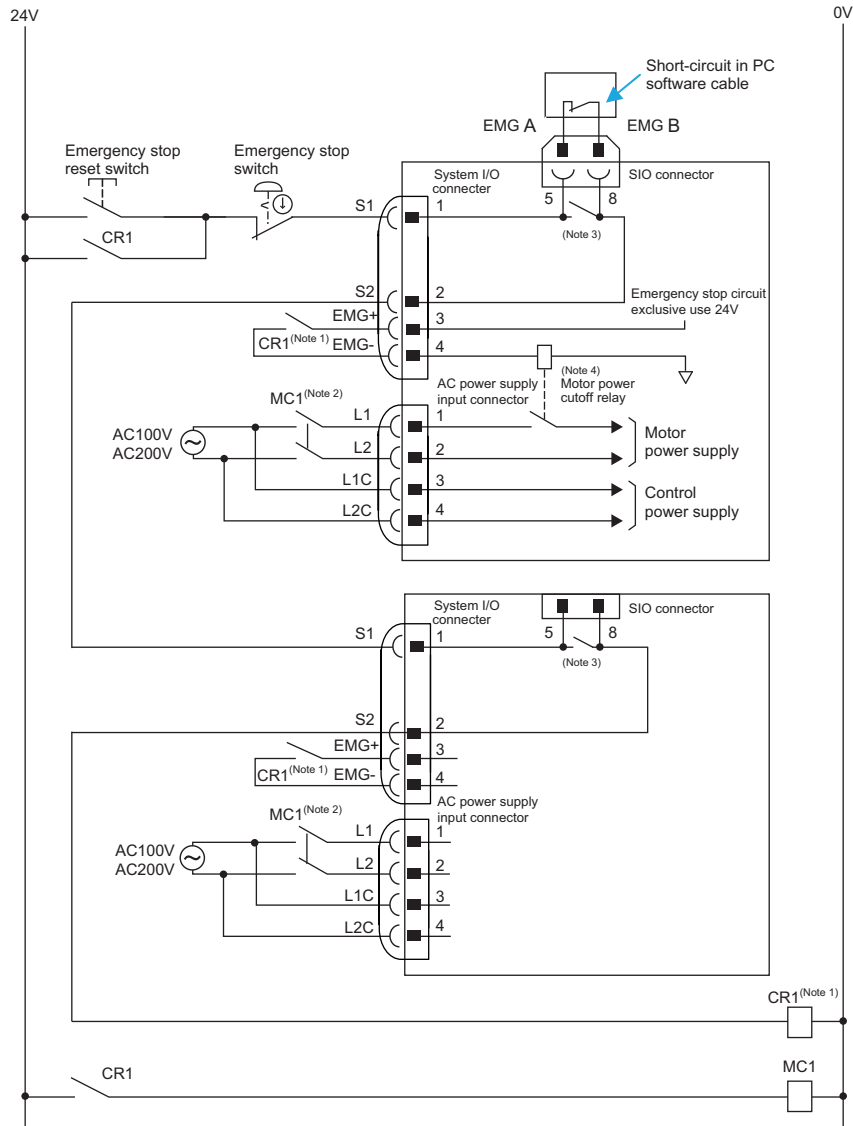

- Note 1 The rating for the emergency stop signal (EMG-) to turn ON/OFF at contact CR1 is 24V DC and 10mA or less.
- Note 2 Connect such as a connector to L1/L2 terminals when cutting off the motor power source externally.  
(CB/LC type are equipped with the drive cutoff relay mounted inside the controller.)
- Note 3 CGB/LCG type are not equipped with a relay to enable to automatically identify a teaching tool was inserted and switch the wiring layout. (The system I/O connector does not get short-circuited between S1 and S2 terminals even if a teaching tool is removed.) The controller on CB/LC type automatically identifies that a teaching tool was inserted. (Short-circuit is made between S1 and S2 terminals inside the controller once connection is detected.)
- Note 4 Since there is no motor power cutoff relay in CGB/LCG type, make sure to establish a cutoff relay externally.

## [4] Motor • Encoder Circuit

Use the dedicated connection cables for the connection between an actuator and controller.

### 1) Connecting the single axis robots (except for RCS2-RA13R)

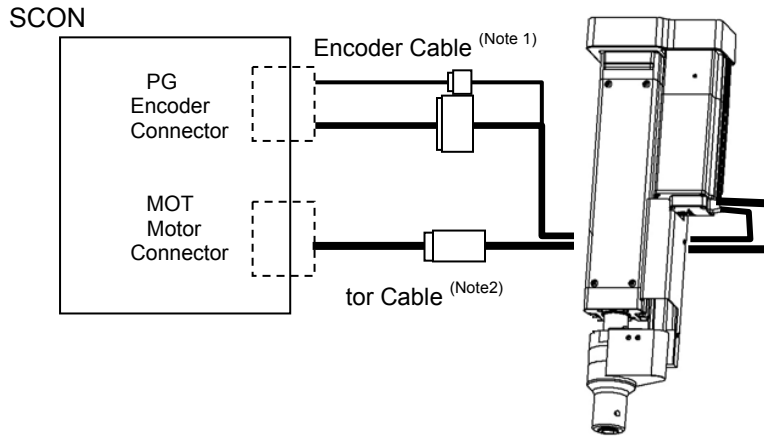

Note 1 Applicable Connection Cable Model Codes □□□ : Cable Length Example) 030 = 3m

Actuator Series Name	Cable
RCS3-RA6/RA7/RA8/RA10	CB-RCS2-PLDA□□□
	CB-RCS2-PLDA□□□-RB (robot cable)

Note 2 Applicable Motor Cable Model Codes □□□ : Cable Length Example) 030 = 3m

Actuator Series Name	Cable
RCS3-RA6/RA7/RA8/RA10, RCS2-RA13R	CB-RCC-MA□□□
	CB-RCC-MA□□□-RB (robot cable)

### 2) Connecting the RCS2-RA13R with loadcell (with no brake)

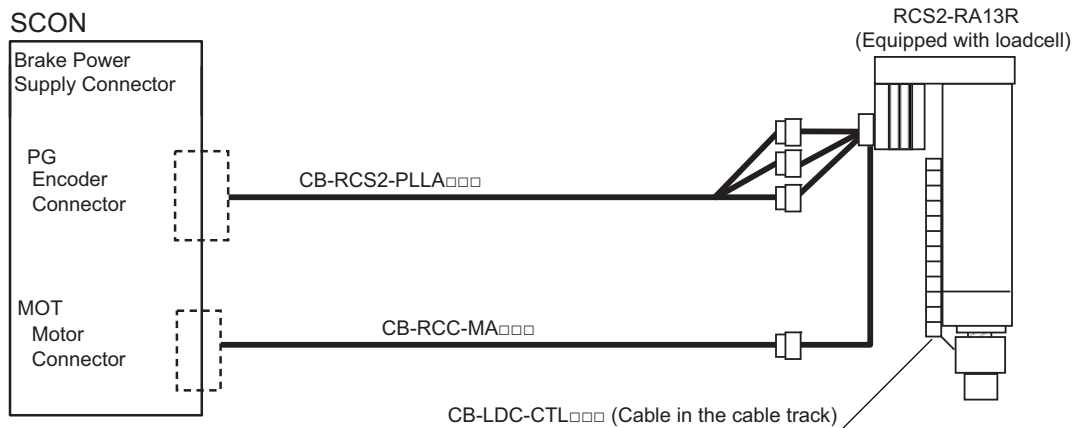

3) Connecting the RCS2-RA13R with loadcell (with brake)

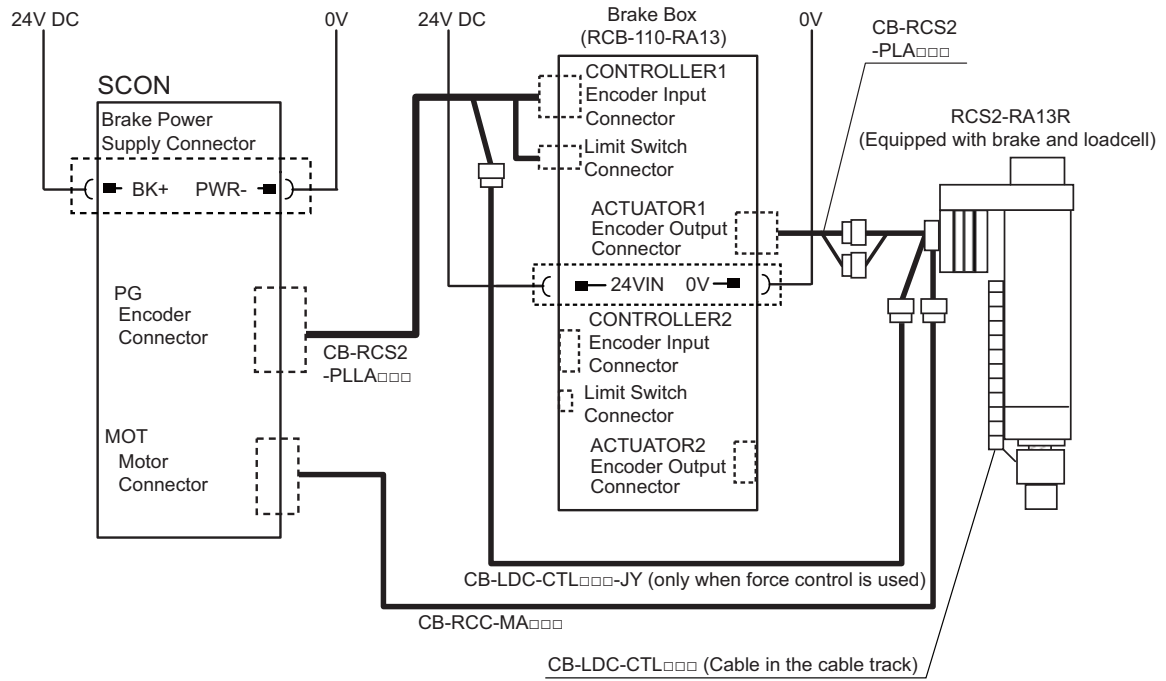

## [5] PIO Circuit

### 1) PIO Circuit for CB/CGB Types

- List of Control Signal Assignments and Features

See the table below for the signal assignment of the I/O flat cable. Follow the following table to connect the external equipment (PLC etc).

Pin No.	Category	Signal Abbreviation	Signal Name	Function Description
1A	24V	P24	P24	Supply 24V DC power for I/O power
2A	24V	P24		
3A	-	-		
4A	-	-		
5A	Input	PC1	Command Program No. 1	Indicate the press program number to make operation. The available to indicate range is 0 to 63. Indicate in the binary data expressed in PC1 to PC32. e.g.) For Program No.3 : PC1, PC2 is turned ON For Program No.10: PC2, PC8 is turned ON For Program No.61: PC1, PC4, PC8, PC16, PC32 is turned ON
6A		PC2	Command Program No. 2	
7A		PC4	Command Program No. 4	
8A		PC8	Command Program No. 8	
9A		PC16	Command Program No. 16	
10A		PC32	Command Program No. 32	
11A		PSTR	Program Start	Turn this signal ON after indicating in the command program number and then the press program starts to be executed. Turn this signal ON while a program is executed or an axis is moving and then an alarm occurs.
12A		PHOM	Program Home Return Movement	Turn this signal ON after indicating in the command program number and then the actuator moves to the <b>program home position of the indicated press program.</b> Turn this signal ON while a program is executed or an axis is moving and then an alarm occurs.
13A		ENMV	Axis Operation Permission	Turn this signal ON and the axis movement and program execution get accepted. For the OFF as condition below: 1) Axis operation stop 2) Press program stop 3) FPST signal input disable 4) Servo ON is continued (Note) When this signal is turned OFF, even if the signal gets turned back ON, the axis movement or program execution that stopped on the way would not resume.
14A		FPST	Program Compulsory Stop	Turn this signal ON and then the program in execution stops. At the time to input this signal, whether to move to the program home position in execution or not can be selected (*).
15A	CLBR	Loadcell Calibration Derecive	Turn this signal ON for more than 20ms to perform calibration (adjustment) of loadcell.	
16A	BKRL	Brake Release	The brake will forcibly be released.	
17A	RMOD	Operation Mode Switch	The operating mode is selectable when the operation mode switch of the controller is set to AUTO. (The setting is AUTO when signal is OFF, and MANU when ON.)	
18A	HOME	Home Return	The controller will perform home return when this signal is turned ON.	
19A	RES	Reset	Turn the signal ON to reset the alarm.	
20A	SON	Servo ON Command	Turn the signal ON to servo ON. Turn the OFF to Servo OFF.	

\* Select the Parameter No.179.

Pin No.	Category	Signal Abbreviation	Signal Name	Function Description																							
1B	Output	PCMP	Program Finished in Normal Condition	This signal turns ON to show that the press program has finished in normal condition and moved to the standby stage. It is kept on till the next press program execution, axis movement command or servo-OFF command.																							
2B		PRUN	Program Executed	This signal turns ON to show the press program is in execution. "In execution" means from the startup of the program till the end of the standby stage. It does not turn ON while in movement to the program home position.																							
3B		PORG	Program Home Position	This signal turns ON to show the current position is at the program home position of the indicated press program.																							
4B		APRC	While in Approaching the Operation	This signal turns ON to show the approach stage in the press program is in operation.																							
5B		SERC	While in Probing Operation	This signal turns ON to show the probing stage in the press program is in operation.																							
6B		PRSS	While in Pressurizing Operation	This signal turns ON to show the pressurize stage in the press program is in operation.																							
7B		PSTP	Pressurize during the Stop	This signal turns ON to show the stop stage in the press program is in operation.																							
8B		MPHM	Program Home Return during the Movement	This signal turns ON in the following conditions; 1) Program home movement 2) While depressurizing stage in the press program is in operation 3) While returning stage in the press program is in operation 4) While in escape operation to the program home position due to an alarm generated 5) While in escape operation to the program home position due to program compulsory finish																							
9B		JDOK	Judgement OK	Total judgment is made from the values of the position and the load at the end of the judgment period. (The result is maintained till execution of next program.)																							
10B		JDNG	Judgement NG	<table border="1"> <thead> <tr> <th rowspan="2">Signal</th> <th colspan="5">Judgement</th> </tr> <tr> <th>Position OK Load</th> <th>Position NG Load</th> <th>Position OK Load</th> <th>Position NG Load</th> <th>Position Invalid Load</th> </tr> </thead> <tbody> <tr> <td>JDOK</td> <td>ON</td> <td>OFF</td> <td>OFF</td> <td>OFF</td> <td>OFF</td> </tr> <tr> <td>JDNG</td> <td>OFF</td> <td>ON</td> <td>ON</td> <td>ON</td> <td>OFF</td> </tr> </tbody> </table>	Signal	Judgement					Position OK Load	Position NG Load	Position OK Load	Position NG Load	Position Invalid Load	JDOK	ON	OFF	OFF	OFF	OFF	JDNG	OFF	ON	ON	ON	OFF
Signal		Judgement																									
		Position OK Load	Position NG Load	Position OK Load	Position NG Load	Position Invalid Load																					
JDOK		ON	OFF	OFF	OFF	OFF																					
JDNG		OFF	ON	ON	ON	OFF																					
11B	CEND	Loadcell Calibration Completion	Turns ON after loadcell calibration is complete. This signal turns OFF if CLBR signal is turned OFF.																								
12B	RMDS	Operation Mode Status Output	Output the controller operation mode status. This signal turns OFF when the controller is in AUTO Mode, and on when in MANU Mode.																								
13B	HEND	Home Return Completion	This signal will turn ON when home return has been completed. It will be kept ON unless the home position is lost.																								
14B	SV	Servo ON Status Output	This signal will remain ON while the servo is ON.																								
15B	*ALM	Alarm	Turns ON when controller in normal condition, and OFF when alarm is generated.																								
16B	*ALML	Light Failure Alarm	OFF when a message level alarm is generated.																								
17B	-	-																									
18B	-	-																									
19B	0V	N	N	Supply 0V DC power for I/O power																							
20B	0V	N																									

(Reference) signal of active low

Signal with "\*" expresses the signal of active low. Active low signal is an output signal of the type is normally ON in the power-on status and turned OFF at signal output.

## • Examples for Connection Circuit

Use the attached cable for the I/O connection.

Model : CB-PAC-PIO□□□ (□□□ indicates the cable length L. Example. 020 = 2m)

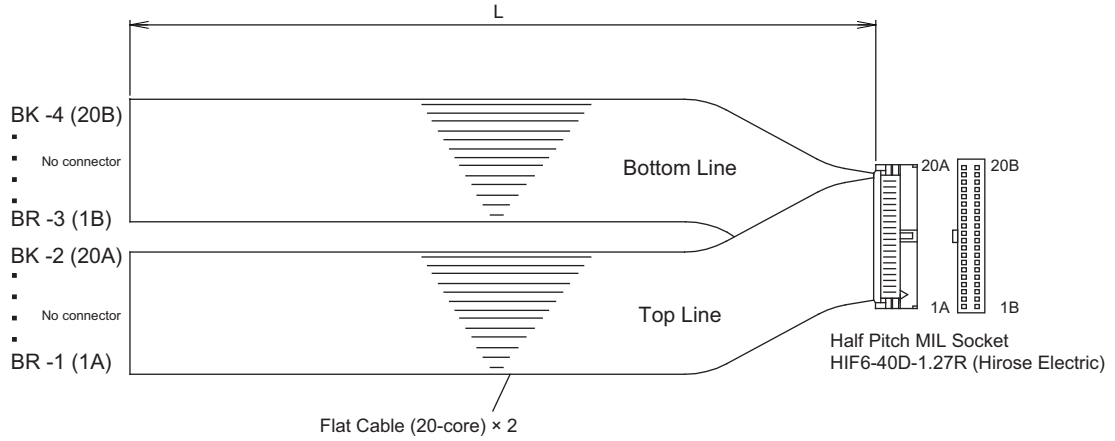

**Caution :** When having a conduction check on the flat cable, make sure not to spread out the inside of the connector female pins. It may cause a contact error and may disable normal operation.

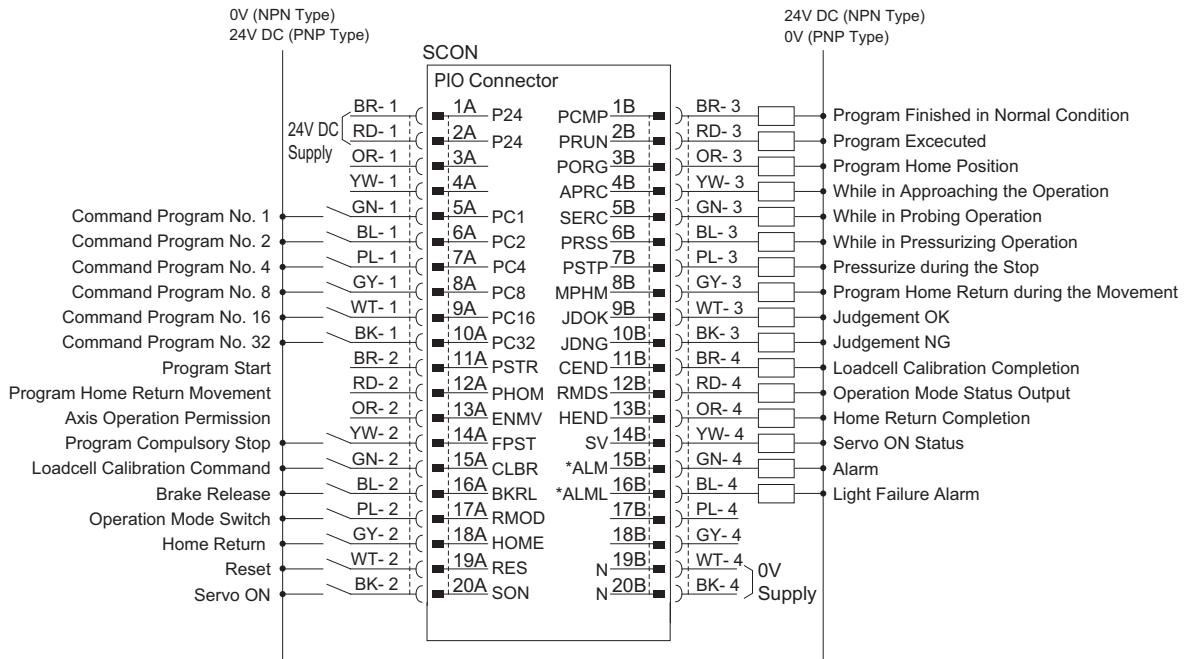

“\*” in codes above shows the signal of the active low. Processing occurs when an input signal of the type is turned OFF. An output signal of the type is normally ON in the power-on status and turned OFF at signal output.

## 2) PIO Circuit for LC/LCG Types

- List of Control Signal Assignments and Features

The table below shows the signal assignment of the flat cable. Follow the following table connect the external equipment (such as PLC).

Refer to LC Ladder Programming Manual (ME0329) provided separately for how to assign memories in built-in ladder or how to use it.

Pin No.	Category	I/O No.	Signal Name	Function Description	Relevant Sections
1A	24V		Power Supply	Power Supply for I/O +24V	
2A	24V		Power Supply	Power Supply for I/O +24V	
3A	NC			Not used	-
4A					
5A	General Input	IN0	X000	They are 24V general-purposed terminals. Assign to the built-in ladder and use them if necessary.	Refer to LC ladder Programming Manual provided separately
6A		IN1	X001		
7A		IN2	X002		
8A		IN3	X003		
9A		IN4	X004		
10A		IN5	X005		
11A		IN6	X006		
12A		IN7	X007		
13A		IN8	X008		
14A		IN9	X009		
15A		IN10	X00A		
16A		IN11	X00B		
17A		IN12	X00C		
18A		IN13	X00D		
19A		IN14	X00E		
20A	IN15	X00F			
1B	General Output	OUT0	X000	They are 24V general-purposed terminals. Assign to the built-in ladder and use them if necessary.	Refer to LC ladder Programming Manual provided separately
2B		OUT1	X001		
3B		OUT2	X002		
4B		OUT3	X003		
5B		OUT4	X004		
6B		OUT5	X005		
7B		OUT6	X006		
8B		OUT7	X007		
9B		OUT8	X008		
10B		OUT9	X009		
11B		OUT10	X00A		
12B		OUT11	X00B		
13B		OUT12	X00C		
14B		OUT13	X00D		
15B		OUT14	X00E		
16B	OUT15	X00F			
17B	NC			Not used	-
18B					
19B	0V		Power Supply	Power Supply for I/O 0V	
20B	0V		Power Supply	Power Supply for I/O 0V	

• Examples for Connection Circuit

Use the attached cable for the I/O connection.

Model : CB-PAC-PIO□□□ (□□□ indicates the cable length L. Example. 020 = 2m)

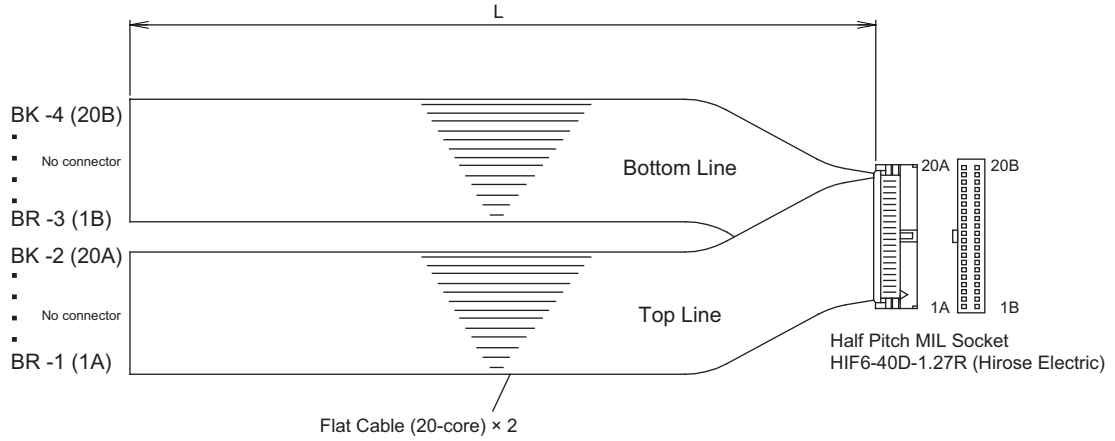

**Caution :** When having a conduction check on the flat cable, make sure not to spread out the inside of the connector female pins. It may cause a contact error and may disable normal operation.

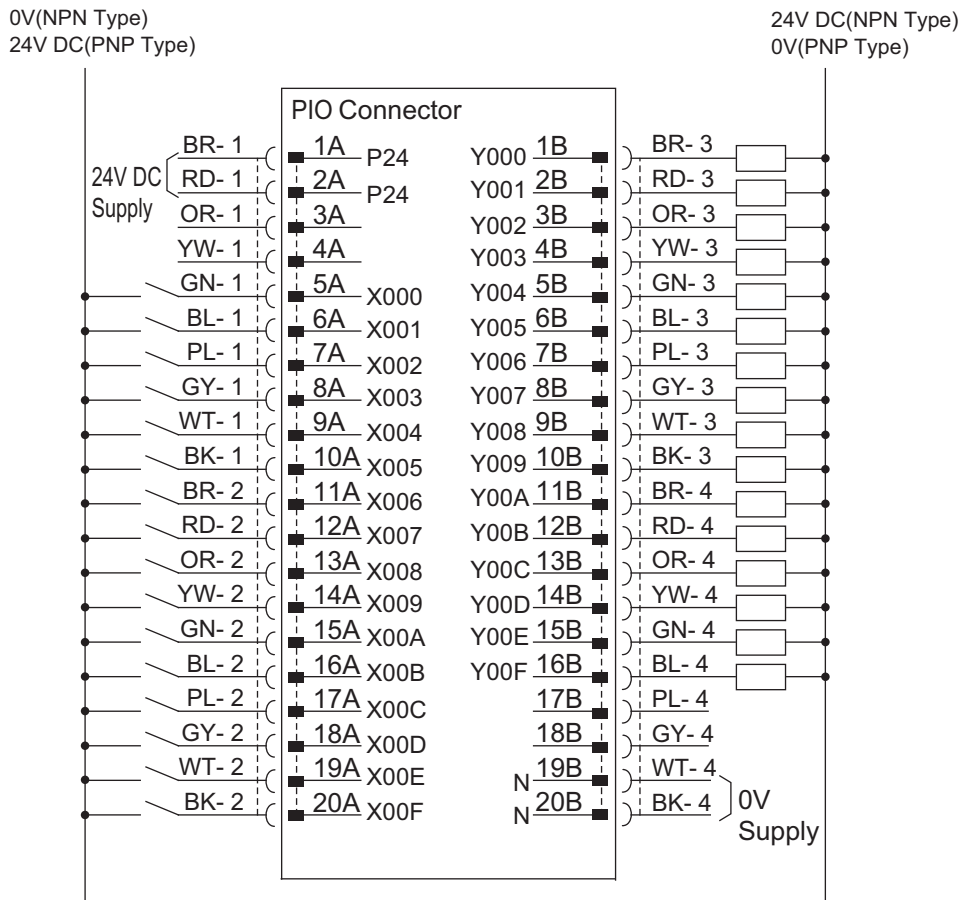

“\*” in codes above shows the signal of the active low. Processing occurs when an input signal of the type is turned OFF. An output signal of the type is normally ON in the power-on status and turned OFF at signal output.



## [6] Circuit of Regenerative Units

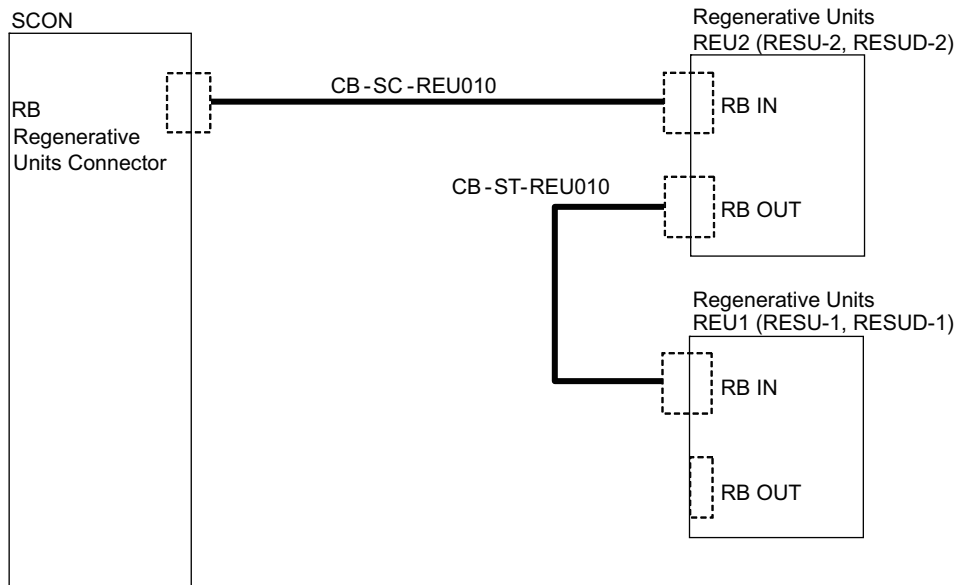

## [7] Multi-function Connector

### 1) When Host Inputting Feedback Pulse with Line Receiver

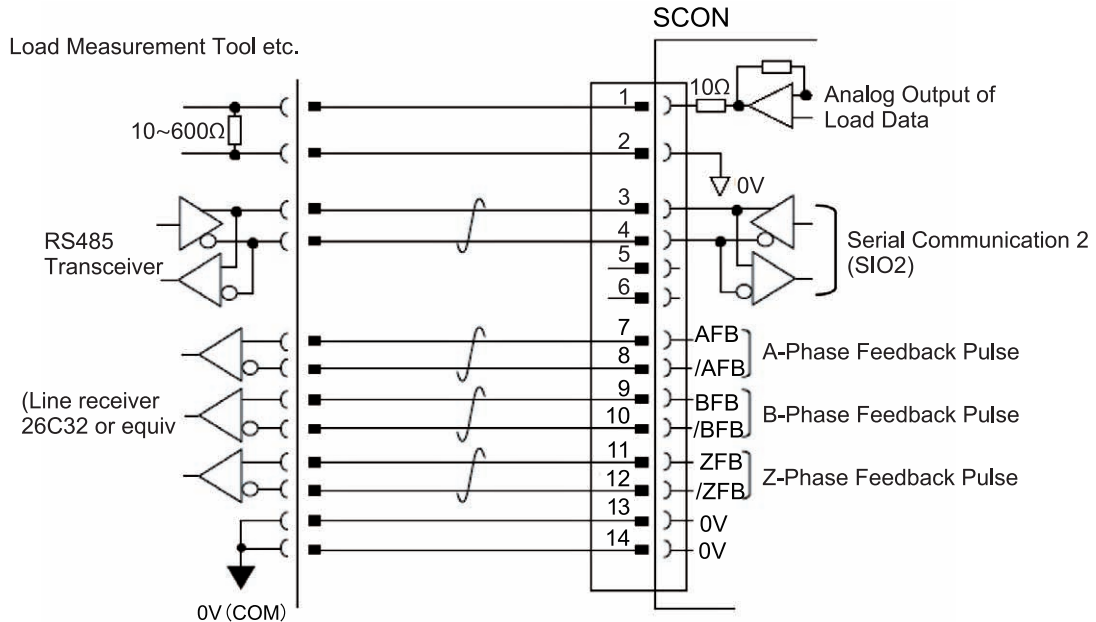

### 2) When Host Inputting Feedback Pulse with Open Collector It is necessary to pulse converter (JM-08 : Option).

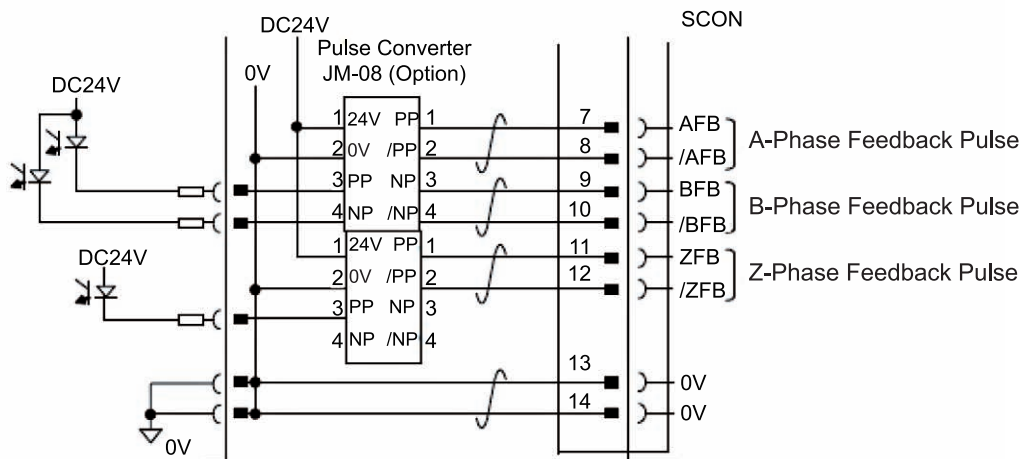

**⚠ Caution: Use the same power source for the positioning unit of the host and JM-08.**

## 2.2 Wiring for Controller for Motors of up to 750W

\* Refer in Section 2.3 and 2.4 for the controller for motors of 3000W and above.

### 2.2.1 Wiring for Power Supply Circuit

Power Supply Type	Specifications	Reference
Motor Power Supply	100V Specification : 100 to 115V AC $\pm$ 10% 50/60Hz	
Control Power Supply	200V Specification : 200 to 230V AC $\pm$ 10% 50/60Hz	

#### 2.2.1.1 Main Power Circuit (Power Supply Connector)

Supply the appropriate power from the following considering the controller type. Loaded current may differ depending on the connected actuators. Select a circuit breaker and leakage breaker that can apply to the specifications. [Refer to section 1.3]

• Image of Wiring

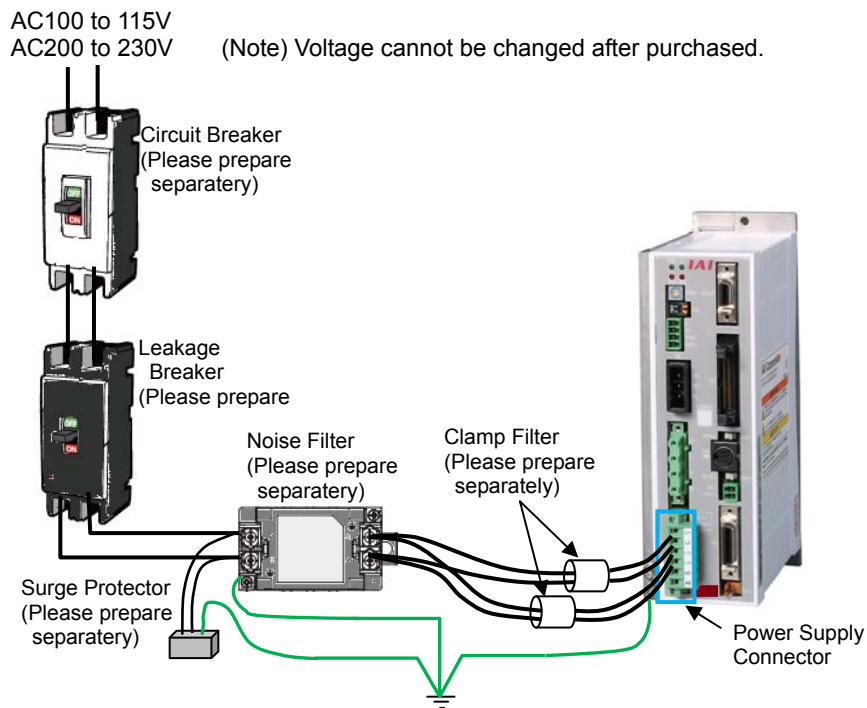

Parts Name	Model	Supplier	Position to attach
1) Noise Filter	NAC-10-472 <sup>(Note)</sup>	COSEL	Attach in range of 300mm or less from controller
	NF2010A-UP <sup>(Note)</sup>	SOSHIN ELECTRIC CO.,LTD	
2) Clamp Filter	ZCAT3035-1330	TDK	Attach as close as possible to controller
3) Surge Protector	R • A • V-781BWZ-2A	Okaya ELECTRIC CO.,LTD	Attach at the input terminal of noise filter

Note It is the model code when one unit of noise filter is connected to one unit of SCON.

**⚠ Caution :** For the noise filter in 1), it is recommended to have one unit connected to one unit of SCON.  
\* Refer also to the [reference] in the next page.  
Attach 2) and 3) if necessary considering the noise environment and the power supply condition. It is recommended to attach them even though it is not mandatory.

[Reference 1 Caution When Connecting Multiple SCON Units to One Unit of Noise Filter

⚠ Caution : When connecting several units of SCON to one unit of noise filter, make sure that each device in the equipment would not get any influence of noise. Also, considering the case that they get influence of noise, ensure space so noise filters or noise prevention component can be additionally allocated.

\* The contents above are not something that guarantees normal operation of the equipment. Check carefully in the actual operational conditions.

[Reference 2] Caution When Selecting Noise Filter

Consider two points as stated below when you select a noise filter.  
Please contact the supplier of each noise filter for details.

- 1) Allowable Current : The power current <sup>(Note 1)</sup> of the controller should be in the range of the allowable current of the noise filter.

◆ Allowable Current of Noise Filter > Rated Current Amperage of Connected Controller

Note 1 : Rated Current Amperage of SCON = Motor Current Amperage + Control Current Amperage

As the rated current amperage differs depending on the connected actuator (motor), it is required to check in the section of 1.2.2 Current Amperage and Heat Radiation for the necessary current value.

- 2) Attenuation Characteristics : A noise filter which possesses the similar attenuation characteristics to the noise filter code stated in the previous page should be selected. The attenuation characteristics of each noise filter is open to the public by each supplier. For example, shown below is the graph of the attenuation characteristics of NAC-10-472 that IAI recommends.

NAC-10-472

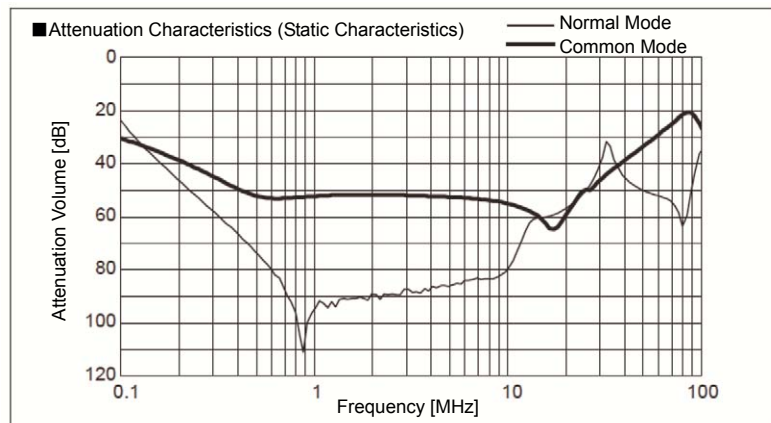

● **Wiring Method**

Connect the wiring of power supply to the enclosed connector (Model code: MSTB2.5/6-STF-5.08: Phoenix Contact).

See below for how to lay out the power supply wires.

- 1) Loosen the terminal screw with using such as a slotted screwdriver to open up the inlet.
- 2) Reveal the sheath for 7mm on the cable that satisfies the cable diameter complies the specification shown in the table below and put it in the inlet.
- 3) Tighten the terminal screw with using such as a slotted screwdriver. The inlet closes and affixes the wire.
- 4) Connect all the wires in the same manner and insert the enclosed connector to the power connector.

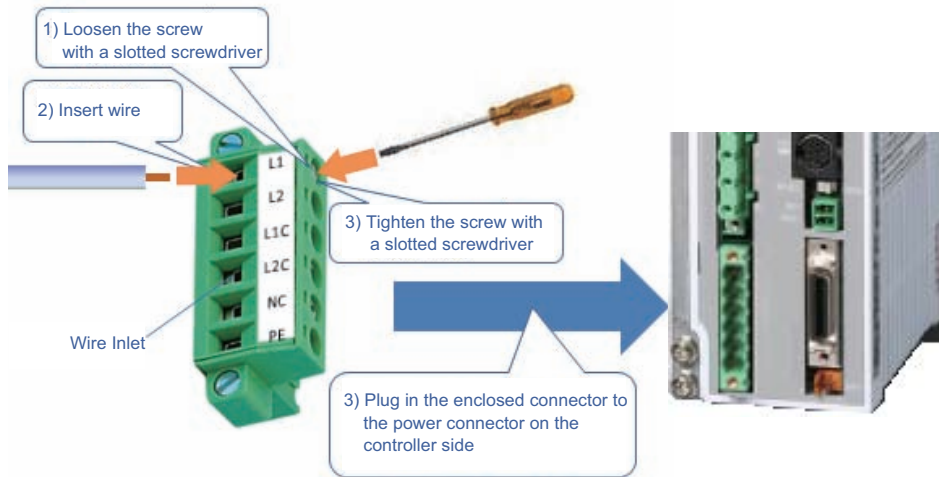

Power supply connector (PWR)

Pin No.	Signal name	Items	Applicable cable diameter
1	L1	Motor power AC input	2.0mm <sup>2</sup> (AWG14)
2	L2		
3	L1C	Control power AC input	0.75mm <sup>2</sup> (AWG18)
4	L2C		
5	NC	Unconnected	
6	PE	Protective grounding wire	2.0mm <sup>2</sup> (AWG14)

## 2.2.1.2 Brake Power Supply (Brake Power Connector)

Supply 24V DC±10% and 1A max. when using an actuator equipped with a brake.

- Image of Wiring

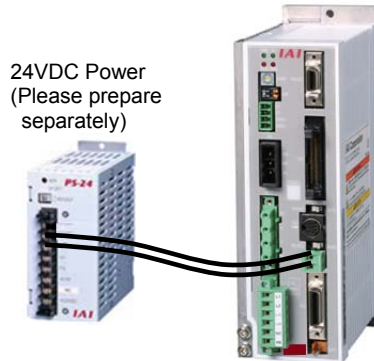

- Wiring Method

Connect the wiring of brake power supply to the enclosed connector (Model code: MC1.5/2-ST-3.5: Phoenix Contact).

See below for how to lay out the power supply wires.

- 1) Loosen the terminal screw with using such as a slotted screwdriver to open up the inlet.
- 2) Reveal the sheath for 7mm on the cable that satisfies the cable diameter complies the specification shown in the table below and put it in the inlet.
- 3) Tighten the terminal screw with using such as a slotted screwdriver. The inlet closes and affixes the wire.
- 4) Connect all the wires in the same manner and insert the enclosed connector to the power connector.

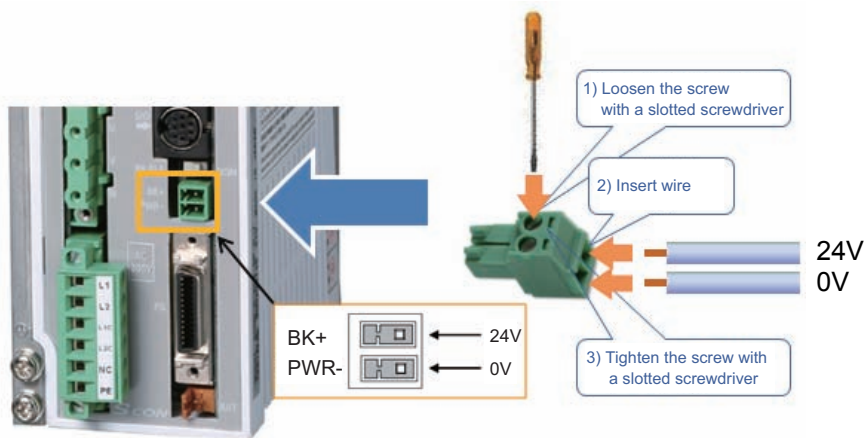

Brake Power Supply Connector

Pin No.	Signal name	Items	Applicable cable diameter
	BK+	24V DC power input	1.25 to 0.5mm <sup>2</sup> (AWG16 to 20)
	PWR-	24V DC ground	

- For Actuators Necessary to Have Brake Box  
 When connecting RCS2-RA13R, it is necessary to have a brake box (RCB-110-RA13-0) connected.  
 [Refer to Section 1.5.3 for details of the brake box.]  
 Supply 24V DC 1A max. as the power supply for the brake box.

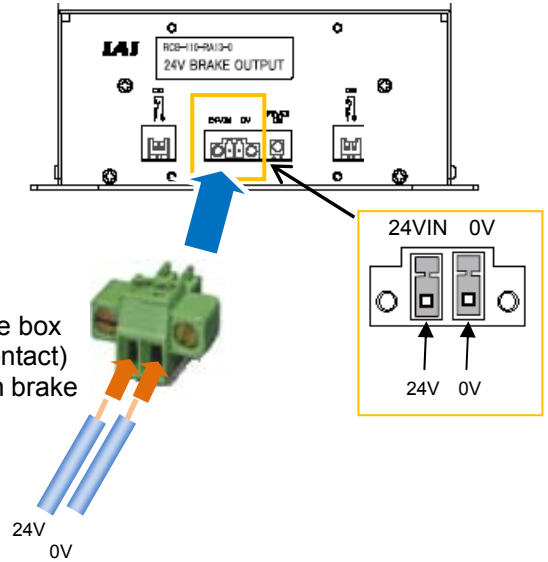

The way to layout wires on the connector enclosed in the brake box (MC1.5/2-STF-3.5: Phoenix Contact) is the same as that described in brake power connector.

## 2.2.2 Wiring of Emergency Stop Circuit (System I/O)

Make sure to construct the wiring of the emergency stop circuit considering the suitability to the Safety Category of the whole system.

- Image of Wiring

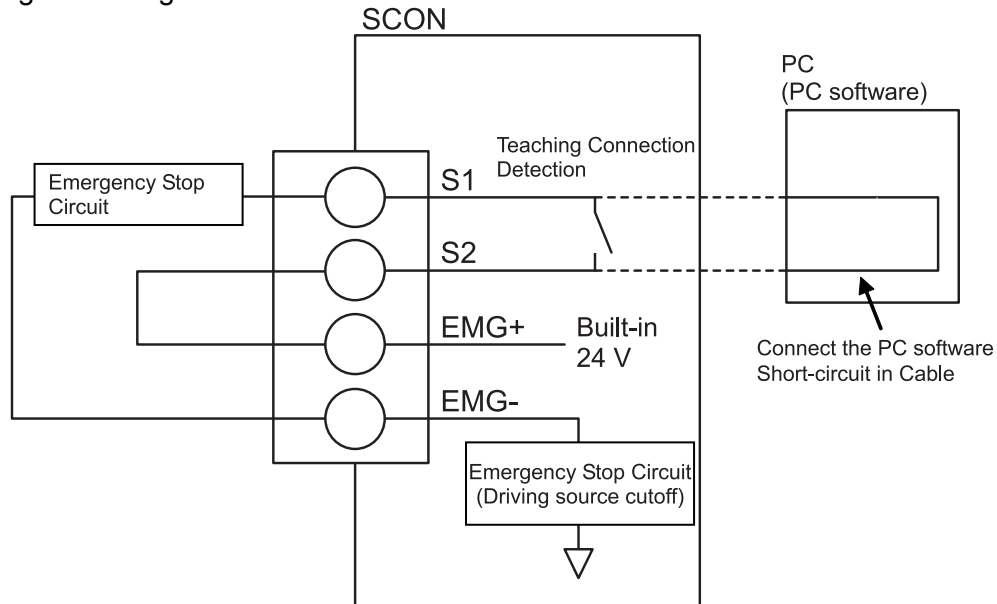

- Note 1 CGB/LCG type are not equipped with a relay to enable to automatically identify a teaching tool was inserted and switch the wiring layout. (The system I/O connector does not get short-circuited between S1 and S2 terminals even if a teaching tool is removed.)  
The controller on CB/LC type automatically identifies that a teaching tool was inserted. (When there is nothing plugged in, S1 and S2 are short-circuited inside the controller.)
- Note 2 Construct the circuit considering the safety category of the whole equipment.
- Note 3 Make sure to construct the emergency stop circuit using the built-in 24V (EMG+ Terminal) output for EMG- Terminal.
- Note 4 There is no motor power cutoff relay in CGB/LCG type.

[Refer to Chapter 9.2 for conformance to Safety Category.]



● **Wiring Method**

Connect the wiring of operation stop (system I/O connector) to the enclosed connector (Model code: FMC1.5/4-ST-3.5: Phoenix Contact).

See below for how to lay out the power supply wires.

- 1) Loosen the terminal screw with using such as a slotted screwdriver to open up the inlet.
- 2) Reveal the sheath for 10mm on the cable that satisfies the cable diameter complies the specification shown in the table below and put it in the inlet.
- 3) Tighten the terminal screw with using such as a slotted screwdriver. The inlet closes and affixes the wire.
- 4) Connect all the wires in the same manner and insert the enclosed connector to the power connector.

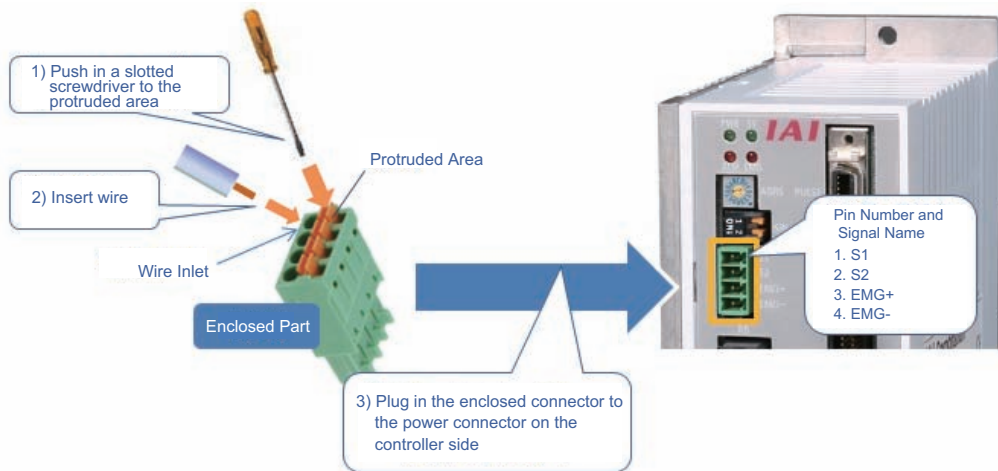

System I/O connector

Pin No.	Signal name	Items	Applicable cable diameter
1	S1	Operation stop switch contact	1.25 to 0.5mm <sup>2</sup> (AWG16 to 20)
2	S2	Operation stop switch contact	
3	EMG+	Operation stop dedicated power output	
4	EMG-	Operation stop input	

### 2.2.3 Connection of Actuator

Connect the motor cable to the MOT connector.  
 Connect the encoder cable to the PG connector.  
 Connect the brake release box if using RCS2-RA13R or NS Type equipped with brake.  
 [Refer to 2.1.2 [4]]

- Image of wiring

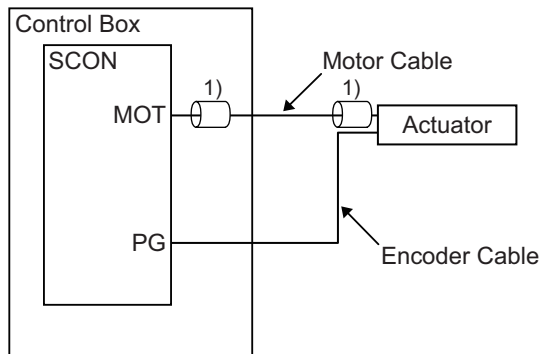
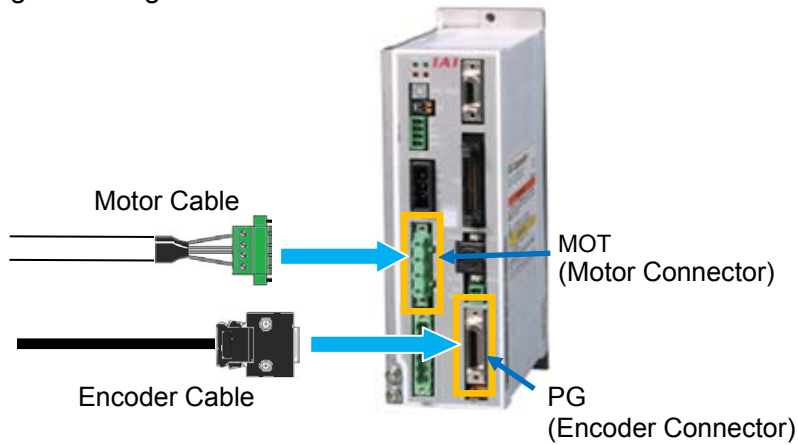

Attach a clamp filter to the motor cable if necessary considering the noise environment.

	Parts Name	Model	Supplier	Position to attach
1)	Clamp Filter	ZCAT3035-1330	TDK	<ul style="list-style-type: none"> <li>• Near SCON</li> <li>• Near Actuator</li> </ul>

**⚠ Caution :** For Absolute Type, remove the absolute battery connector from the controller before connecting the encoder cable.

**Motor Connector (MOT)**

	Model	Remarks
Cable Side	GIC2.5/4-STF-7.62	
Controller Side	GIC2.5/4-GF-7.62	

Pin No.	Signal name	Items	Applicable cable diameter
1	PE	Protective grounding wire	Dedicated cable for IAI actuator
2	U	Motor drive U-phase	
3	V	Motor drive V-phase	
4	W	Motor drive W-phase	

**Encoder Connector (PG)**

	Model	Remarks
Cable Side	10126-3000VE	
Controller Side	10226-6202JL	

Pin No.	Signal name	Items	Applicable cable diameter
1	A+	Phase A Difference + Input (Phase U+)	Cable dedicated for IAI encoders
2	A-	Phase A Difference - Input (Phase U-)	
3	B+	Phase B Difference + Input (Phase V+)	
4	B-	Phase B Difference - Input (Phase V-)	
5	Z+	Phase Z Difference + Input (Phase W+)	
6	Z-	Phase Z Difference - Input (Phase W-)	
7	SRD+	Send/Receive Difference + (Pulse/Magnetic Pole Changeover +)	
8	SRD-	Send/Receive Difference - (Pulse/Magnetic Pole Changeover -)	
9	LC_SRD+	Loadcell Communication +	
10	LC_SRD-	Loadcell Communication -	
11	NC	Unconnected	
12	E24V	Sensor Power Output	
13	0V	24V Power Supply GND	
14	BAT+	Backup Battery Power Supply	
15	BAT-	Battery Ground	
16	VCC	Encoder Power	
17	GND	GND	
18	LC_VCC	Loadcell Power +	
19	LC_GND	Loadcell Power -	
20	BKR-	Brake Release Output Signal - (COM : Common to All Axes)	
21	BKR+	Brake Release Output Signal +	
22	NC	Unconnected	
23	RSV	Sensor Input (Reserve)	
24	OT	Sensor Input (Over Travel)	
25	CREEP	Sensor Input (Creep sensor)	
26	LS	Sensor Input (limit switch)	

### 2.2.4 Connection of PIO

For the signal assignment of each wire, refer to the following considering the operation mode.

- Image of wiring

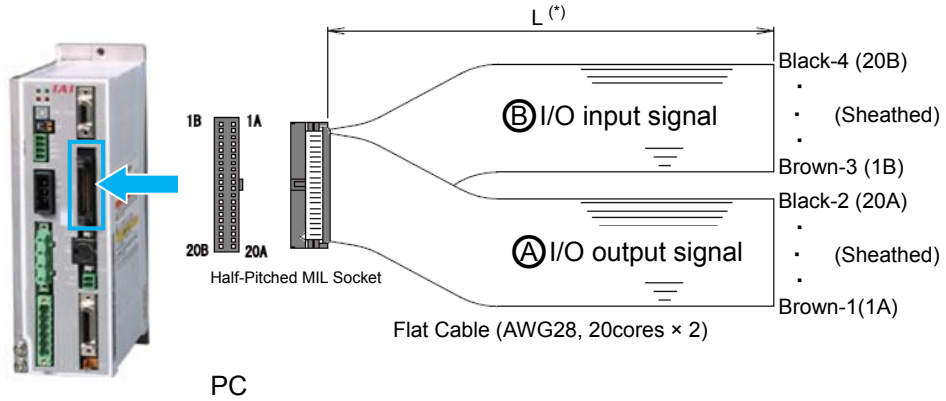

\* Indicate the enclosed I/O cable length in "m" unit in the controller model code. (MAX. 5m)  
 Up to 10m is available at maximum with separate sold option.  
 (Model: CB-PAC-PIO□□□: □□□ is cable length L e.g. 020 = 2m)

No.	Cable Color	Wiring	No.	Cable Color	Wiring
1A	BR-1	Flat Cable (A) (Solderless) AWG28	1B	BR-3	Flat Cable (B) (Solderless) AWG28
2A	RD-1		2B	RD-3	
3A	OR-1		3B	OR-3	
4A	YW-1		4B	YW-3	
5A	GN-1		5B	GN-3	
6A	BL-1		6B	BL-3	
7A	PL-1		7B	PL-3	
8A	GY-1		8B	GY-3	
9A	WT-1		9B	WT-3	
10A	BK-1		10B	BK-3	
11A	BR-2		11B	BR-4	
12A	RD-2		12B	RD-4	
13A	OR-2		13B	OR-4	
14A	YW-2		14B	YW-4	
15A	GN-2		15B	GN-4	
16A	BL-2		16B	BL-4	
17A	PL-2		17B	PL-4	
18A	GY-2		18B	GY-4	
19A	WT-2		19B	WT-4	
20A	BK-2		20B	BK-4	

- Wiring Method

Conduct the connection of I/O to the controller is to be carried out using the dedicated I/O cable. Cable length is to be indicated in the controller model code. Please check the controller model code. A desired I/O cable can be selected from 2m (standard), 3m, and 5m cables. Up to 10m I/O cables are sold separately.

## 2.2.5 Multi-function Connector

The multi-function connector is equipped with following interfaces.

- 1) Analog output of load data
- 2) Feedback pulse output
- 3) Serial communication port 2 (SIO2)

[1] Image of wiring

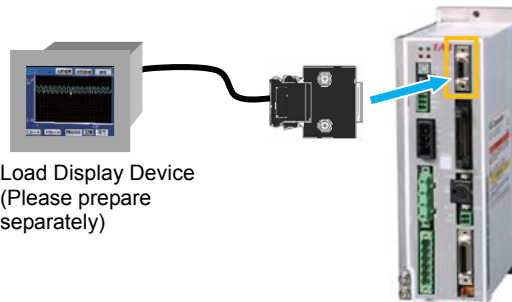

[2] Multi-function connector (MF I/F)

	Model	Remarks
Cable Side	10114-3000PE (3M)	
Controller Side	10214-52A2PL (3M)	

Pin No.	Signal name	Items	Applicable cable diameter
1	IOUT	Load data detected at loadcell is output as analog data (current)	0.2mm <sup>2</sup> (AWG24)
2	GND		
3	SD+	SIO communication line for display device For display of each data	
4	SD-		
5	-	Not used	
6	-		
7	AFB	Feedback pulse (+A)	
8	/AFB	Feedback pulse (-A)	
9	BFB	Feedback pulse (+B)	
10	/BFB	Feedback pulse (-B)	
11	ZFB	Feedback pulse (+Z)	
12	/ZFB	Feedback pulse (-Z)	
13	GND	0V (For feedback pulse)	
14	GND	0V (For SIO communication line)	

## [3] Wiring Method

**⚠ Caution:** Enclosed only in plug and shell.  
Do the same wiring layout as the following option.

Connect the multi-function connector to the enclosed connector (Model: 10114-3000PE). See below for how to lay out the power supply wires.

- 1) Prepare a cable.  
(Multiple twisted pair shielded cable with AWG24 (0.2mm<sup>2</sup>) or cable enclosed in the connected unit (host side))
- 2) Solder to the connector directly.  
Pay attention not to have short circuit with a terminal next to it by having pretinning and so on.

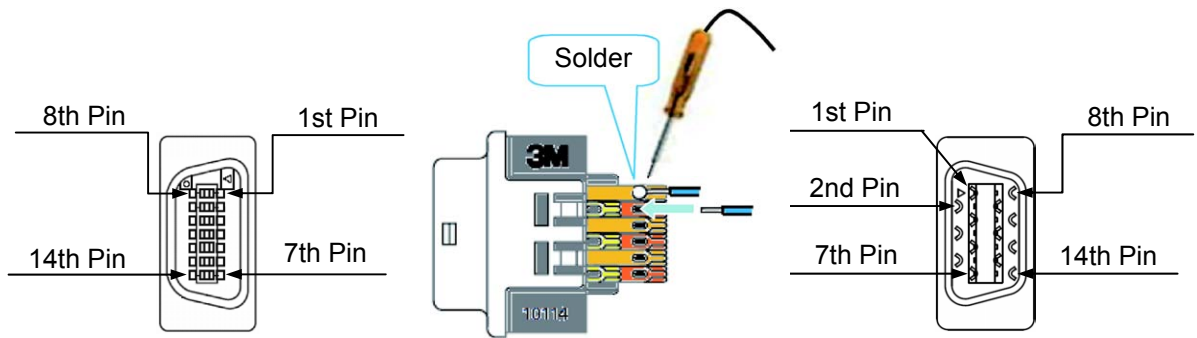

## [4] Connector with Cable (Option)

Model: CB-SC-PIOS□□□ □□□ is cable length: e.g. 020 = 2m  
Cable length: For differential system, MAX. 10m  
For open collector, MAX. 2m

(Note) There is no connector equipped on the host controller (PLC, etc.) side. Make an appropriate treatment that suits the host controller (PLC, etc.). Also, to prevent the noise influence as much as possible, make the cable as short as possible.

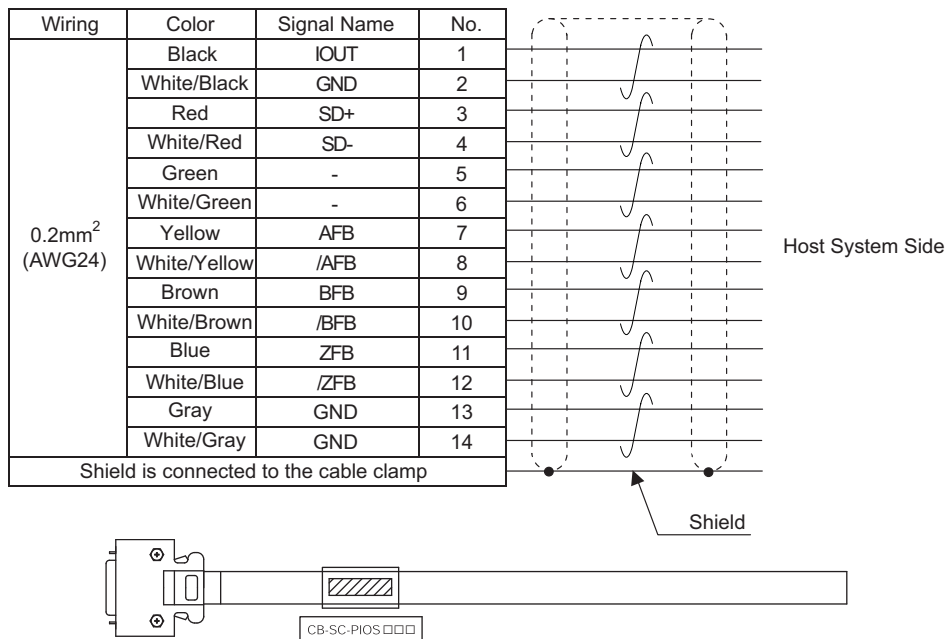

[5] Pulse Converter: JM-08

The pulse converter converts command pulses in the those in the differential mode to open collector mode.

Use this converter if the host controller sends output pulses in the applicable for open collector (24V type).

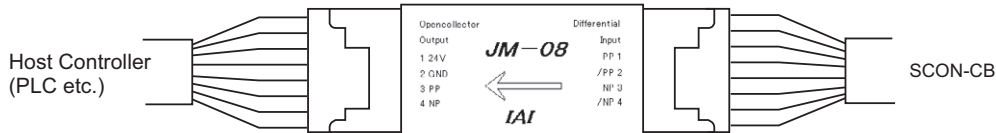

**⚠ Caution :**

- 1) Pay attention not to insert wrongly because it is the same e-CON connector as input and output. Putting the power on with the insertion being wrong will burn JM-08.
- 2) Use the pulse converter in the ambient temperature range between 0°C to 40°C.
- 3) The temperature increase of about 30°C occurs during operation. Accordingly, neither install several pulse converters in close contact nor install them within a duct. Do not install the pulse converter near other heating devices.
- 4) If more than one pulse converters are installed, set a pulse converter apart from another by 10mm or more.
- 5) Make the wiring between the host controller (PLC etc.) and JM-08 as short as possible.  
Long wires make it easy to pick up noise. Also make the wiring between JM-08 to SCON controller as short as possible. Place JM-08 close to the host controller.

A recommended installation sample is shown in the figure below.

- Make the cable length between the host controller and pulse converter as short as possible.

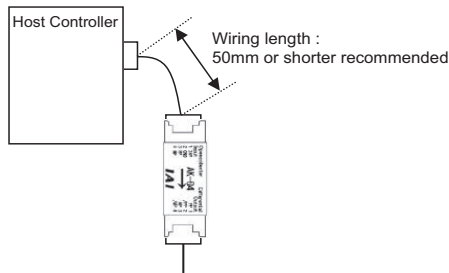

- Keep pulse converters separated for 10mm or more from each other.

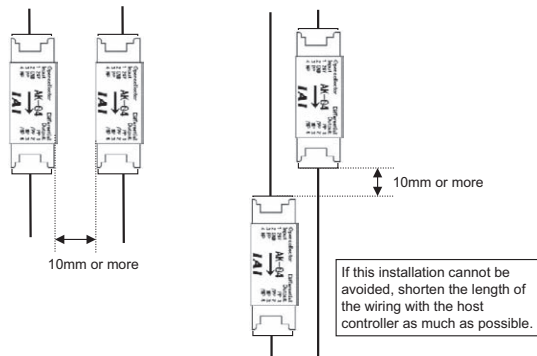

## 2.2.6 Connection of Regenerative Unit

Connect regenerative unit (s) with attached cables as shown in the figure below.

- 1) When connecting 1 unit : Connect with enclosed cable (CB-SC-REU)
- 2) When connecting 2 or more units : Connect with enclosed cable (CB-ST-REU)

- Image of wiring

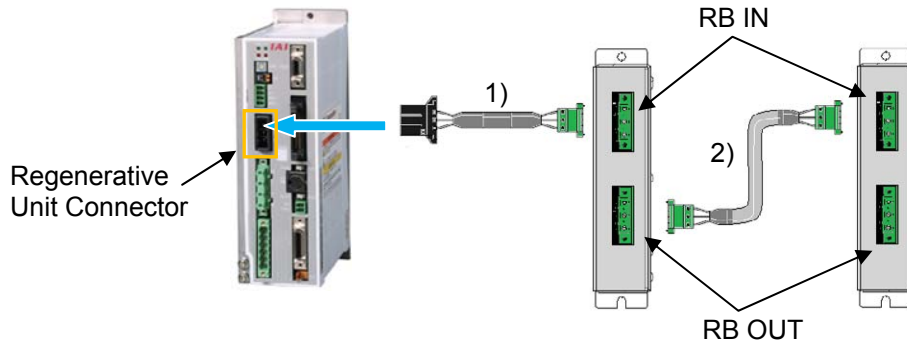

- Specification of connector for connecting external regenerative unit

Item	Items and Model	
Connector Name	External Regenerative Unit Connector (RB)	
Cable Side	1-178128-3	
Controller Side	1-178138-5	

Pin No.	Signal name	Items	Applicable cable diameter
	RB+	Regenerative resistor+ (Motor drive DC voltage)	Dedicated cable is enclosed to regenerative unit
	RB-	Regenerative resistor-	
	PE	Grounding Terminal	

- [Reference for the number of connected units: except for RCS2-RA13R]

Wattage of Motor		Number of Connected Regenerative Units
Horizontal Orientation /Vertical Orientation	to 100W	Not necessary
	101 to 400W	1
	401 to 750W	2

- [Reference for the number of connected units: RCS2-RA13R]

Wattage of Motor		Number of Connected Regenerative Units
Horizontal Orientation	Lead 1.25	Not necessary
	Lead 2.5	1
Vertical Orientation	Lead 1.25	1
	Lead 2.5	1



**⚠ Caution:** 1. The reference table for the number of connected units a reference assuming back and forth operation is made in rated acceleration/deceleration speed with rated load for 1000mm stroke with the actuator operation duty 50%.

2. Regenerative energy is absorbed inside the controller and when it exceeds the limit, error code "OCA" overheat error is generated. Add an external regenerative unit if this occurs.

More units of regenerative unit than referred in the table for the number of connected units are required if the operation duty is higher than 50%. The maximum quantity of the external regenerative units that can be connected is as stated below:

Less than 400W ····· 2 units  
 400W or more ····· 4 units  
 (Never attempt to connect more than described above since it may cause a malfunction.)

[1] Connecting Cable

1) Regenerative resistor connection cable for SCON (CB-SC-REU□□□)

□□□ is cable length (e.g.) 010 = 1m

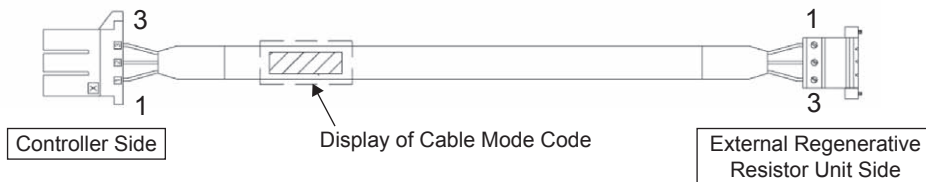

Wiring	Color	Signal	No.	No.	Signal	Color	Wiring
KIV 1.0mm <sup>2</sup> (AWG17)	Light Blue	RB+	1	1	RB+	Light Blue	KIV 1.0mm <sup>2</sup> (AWG17)
	Brown	RB-	2	2	RB-	Brown	
	Green/Yellow	PE	3	3	PE	Green/Yellow	

2) Regenerative resistor connection cable for XSEL (CB-ST-REU□□□)

□□□ is cable length (e.g.) 010 = 1m

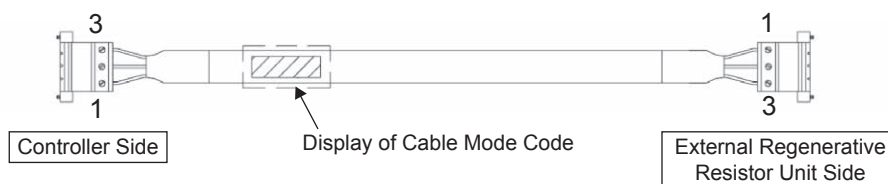

Wiring	Color	Signal	No.	No.	Signal	Color	Wiring
KIV 1.0mm <sup>2</sup> (AWG17)	Light Blue	RB+	1	1	RB+	Light Blue	KIV 1.0mm <sup>2</sup> (AWG17)
	Brown	RB-	2	2	RB-	Brown	
	Green/Yellow	PE	3	3	PE	Green/Yellow	

## 2.2.7 SIO Connector Connection

SIO connectors can be used not only for the connection of teaching tool, but also for the connection of the host controller (PLC, touch panel and PC).

For the operation, refer to the instruction manual of each module.

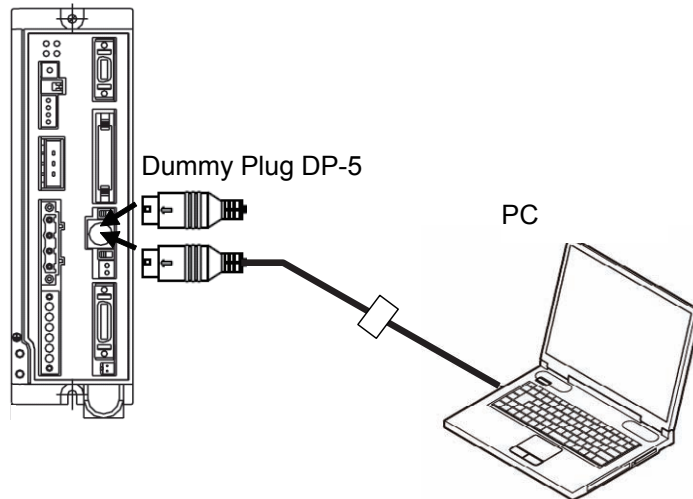

SIO Connector	Items and Model	
Connector Name	SIO Connector	
Cable Side	miniDIN 8 Pin	
Controller Side	TCS7587-0121077	

Pin No.	Signal name	Items	Applicable cable diameter
1	SGA	Teaching tool signal+	Dedicated connection cables provided by us
2	SGB	Teaching tool signal-	
3	5V	Power supply for teaching tool	
4	ENB	Enable signal input	
5	EMGA	Emergency stop signal A	
6	24V	Power supply for teaching tool	
7	0V	0V	
8	EMGB	Emergency stop signal B	
Shell	0V	0V	

**⚠ Caution :** Removing the SIO connector while the power is ON causes a transient emergency stop. Thus, the devices such as the actuator which are in operation will stop.  
Do not disconnect the SIO connector during the operation.  
For SCON-CGB, in case the SIO connector is not used, make sure to insert the dummy plug DP-5 for teaching pendant.

## 2.3 Servo Press Controller for Motors of 3000W and above (PIO Control)

\* Refer in Section 2.1 for the controller for motors of to 750W.

### 2.3.1 Wiring Diagram (Connection of Devices)

[1] Basic Wiring Diagram

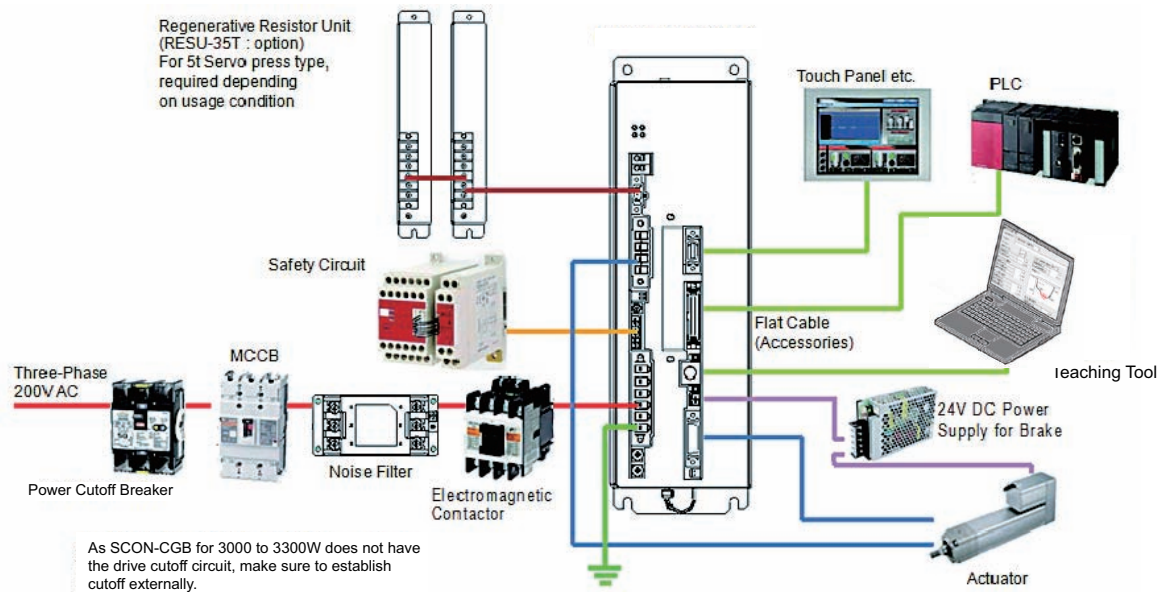

**Caution :** Make sure to turn the power to the controller OFF when inserting or removing the connector that connects the PC software or touch panel teaching to the controller.  
Inserting or removing the connector while the power is turned ON causes a controller failure.

## 2.3.2 Wiring

### [1] Main Power Circuit

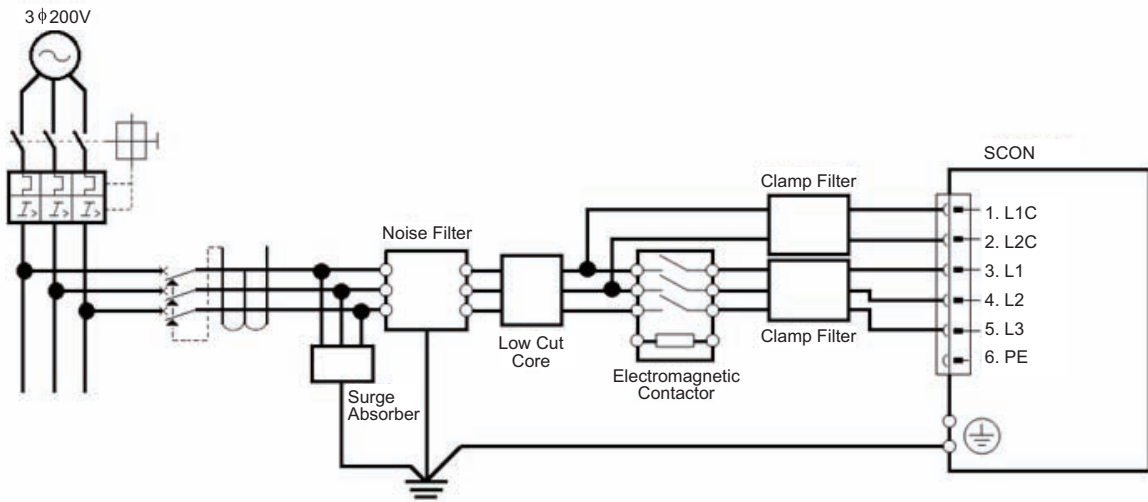

### [2] Brake Power Supply Circuit

When using an actuator equipped with a brake, supply 24V DC to the controller and the actuator.

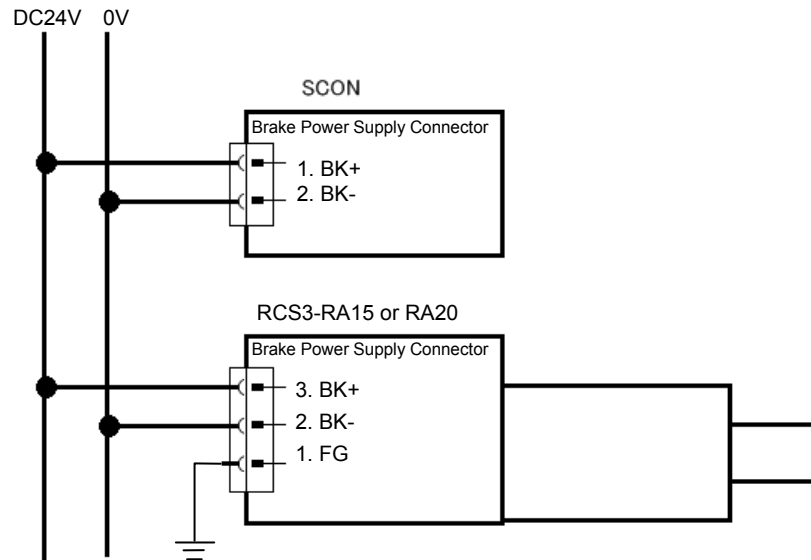

Brake Power Supply Connector Type (Cable Side)

- SCON : MC1.5/2-ST-3.5 (Phoenix Contact)
- RCS3-RA15/RA20 : MC1.5/3-STF-3.5 (Phoenix Contact)

### [3] Actuator Emergency Stop Circuit (System I/O Connector)

As an example of a circuit, cases of 2 conditions are shown.

\* The controller for motors of 3000W and above is not equipped with the built-in SIO connector connection detection circuit and drive cutoff circuit.

★Reference: Operate the actuator for try (Note: It is not emergency stop)

- 1) Stop supplying external motor power at emergency stop input
- 2) Example for Wiring for Equivalent to Safety Category 4

★Reference: Make the emergency stop input (EMG-) of the device valid and have a trial drive of the actuator.

#### • Example of a Circuit

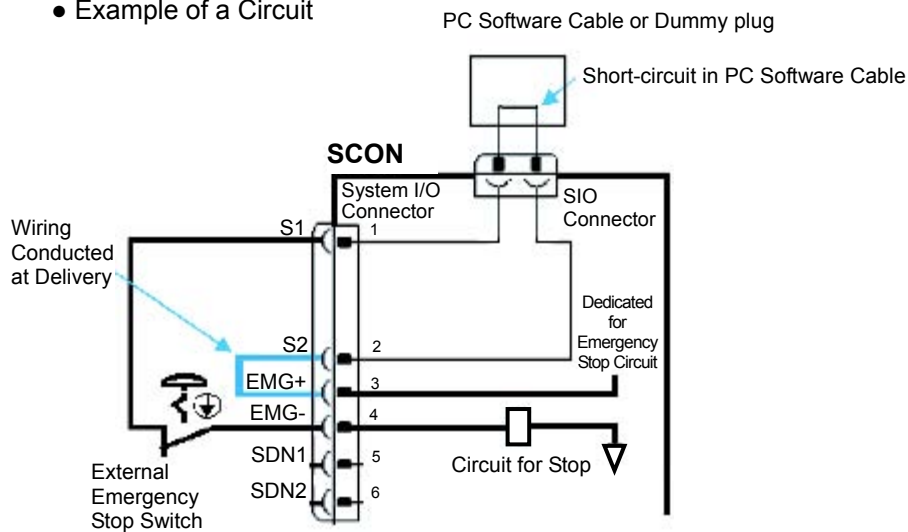

#### • Image of Wiring

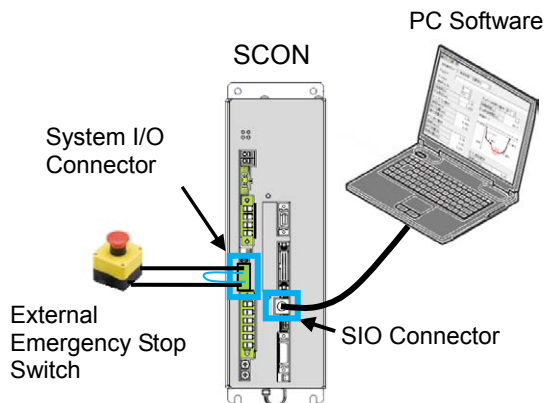

1) Stop supplying external motor power at emergency stop input

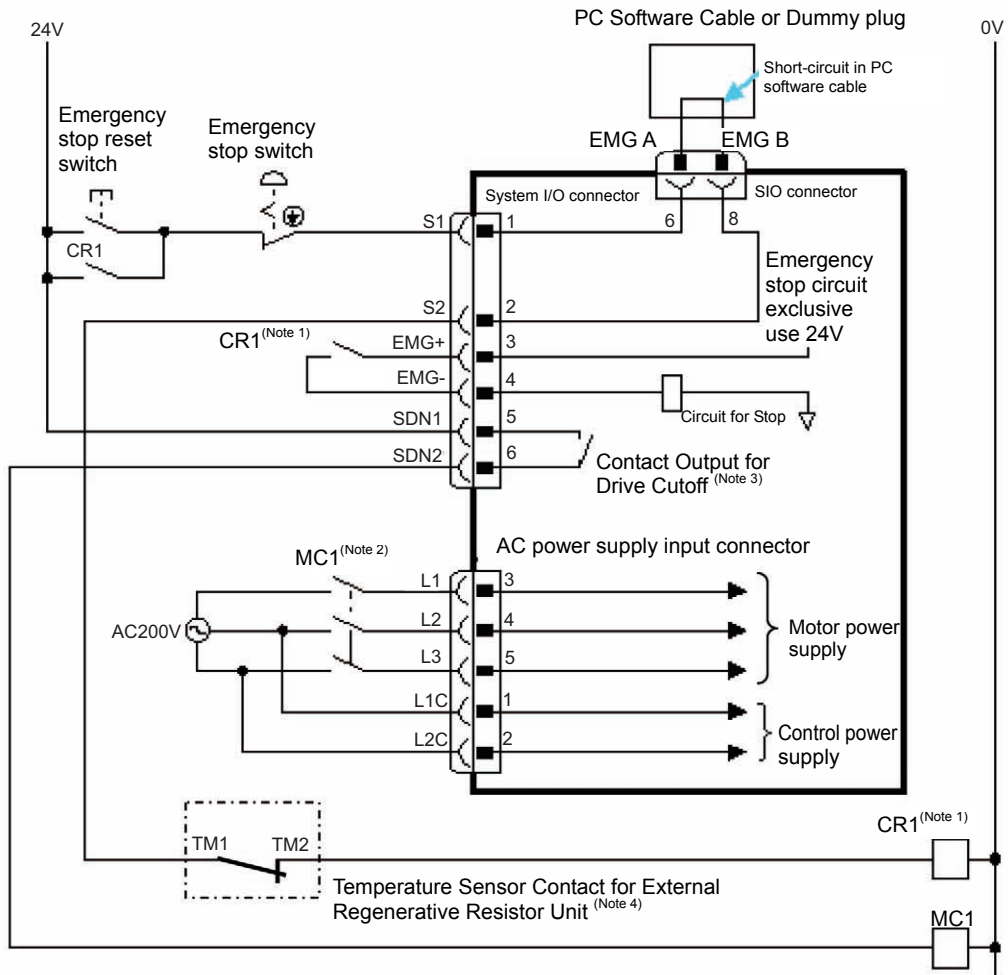

- Note 1 The rating for the emergency stop signal to turn ON/OFF at contact CR1 is 24V DC and 10mA or less.
- Note 2 Connect such as a connector to L1/L2/L3 terminals when cutting off the motor power source externally.  
(This controller is not equipped with internal drive cutoff relay.)
- Note 3 It is the contact output to control the drive cutoff device connected externally. The rating is 30V DC and 200mA or less. [Refer to 2.4.2 for detail]
- Note 4 Connect the temperature sensor contact when external regenerative resistor units are connected.

2) Example for Wiring for Equivalent to Safety Category 4

In order to construct a system applicable for the Safety Categories, use the TP adaptor (RCB-LB-TGS) and establish the circuit construction following the example below.

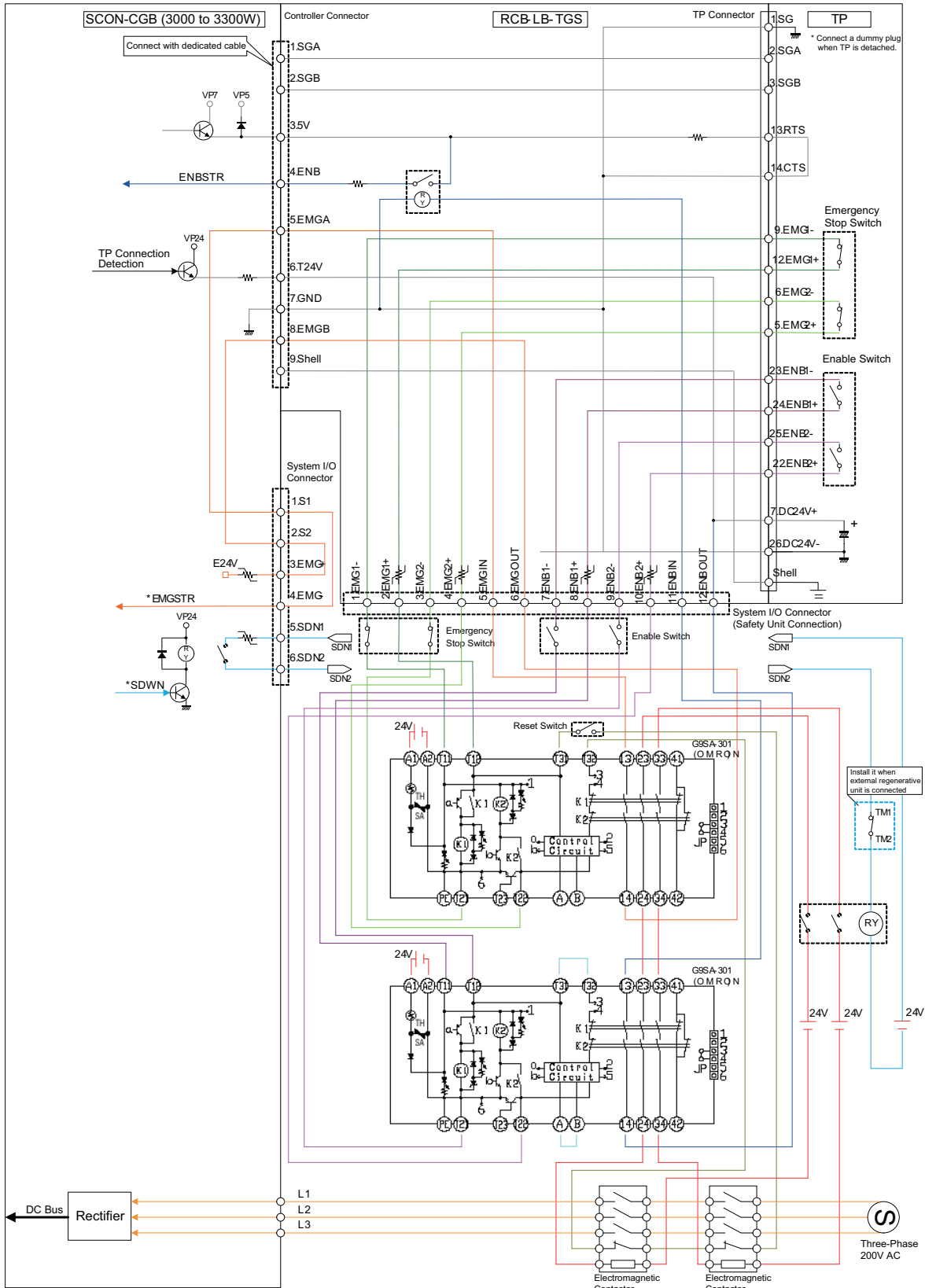

[4] Motor • Encoder Circuit

Use the dedicated connection cables for the connection between an actuator and controller.  
 \* In the case of brake specification, please provide the DC24V to the actuator [Refer to 2.4.1.2 for details.]

1) Connecting the single axis robots

SCON

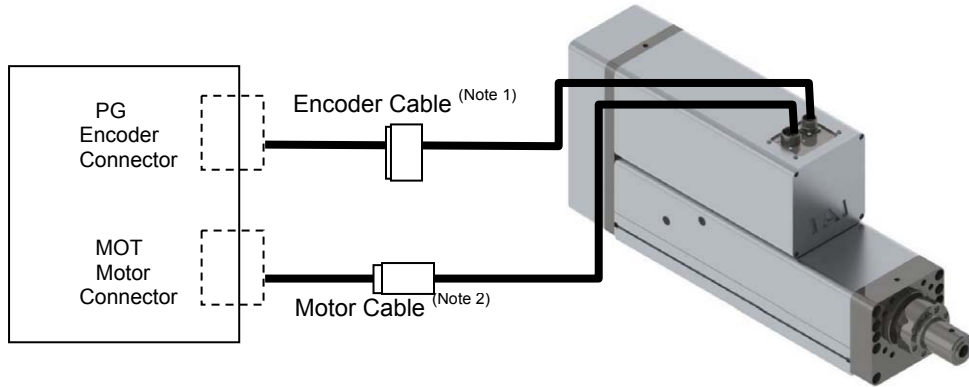

Note 1 Applicable Encoder Cable Model Codes □□□ : Cable Length Example) 030 = 3m

Actuator Series Name	Cable
RCS3-RA15/RA20	CB-RCS3-PLA□□□-RB (robot cable)

Note 2 Applicable Motor Cable Model Codes □□□ : Cable Length Example) 030 = 3m

Actuator Series Name	Cable
RCS3-RA15/RA20	CB-RCS3-MA□□□-RB (robot cable)



## [5] PIO Circuit

### 1) PIO Circuit for CB/CGB Types

- List of Control Signal Assignments and Features

See the table below for the signal assignment of the I/O flat cable. Follow the following table to connect the external equipment (PLC etc).

Pin No.	Category	Signal Abbreviation	Signal Name	Function Description
1A	24V	P24	P24	Supply 24V DC power for I/O power
2A	24V	P24		
3A	-	-		
4A	-	-		
5A	Input	PC1	Command Program No. 1	Indicate the press program number to make operation. The available to indicate range is 0 to 63. Indicate in the binary data expressed in PC1 to PC32. e.g.) For Program No.3 : PC1, PC2 is turned ON For Program No.10: PC2, PC8 is turned ON For Program No.61: PC1, PC4, PC8, PC16, PC32 is turned ON
6A		PC2	Command Program No. 2	
7A		PC4	Command Program No. 4	
8A		PC8	Command Program No. 8	
9A		PC16	Command Program No. 16	
10A		PC32	Command Program No. 32	
11A		PSTR	Program Start	Turn this signal ON after indicating in the command program number and then the press program starts to be executed. Turn this signal ON while a program is executed or an axis is moving and then an alarm occurs.
12A		PHOM	Program Home Return Movement	Turn this signal ON after indicating in the command program number and then the actuator moves to the <b>program home position of the indicated press program.</b> Turn this signal ON while a program is executed or an axis is moving and then an alarm occurs.
13A		ENMV	Axis Operation Permission	Turn this signal ON and the axis movement and program execution get accepted. For the OFF as condition below: 1) Axis operation stop 2) Press program stop 3) FPST signal input disable 4) Servo ON is continued (Note) When this signal is turned OFF, even if the signal gets turned back ON, the axis movement or program execution that stopped on the way would not resume.
14A		FPST	Program Compulsory Stop	Turn this signal ON and then the program in execution stops. At the time to input this signal, whether to move to the program home position in execution or not can be selected (*).
15A	CLBR	Loadcell Calibration Detective	Turn this signal ON for more than 20ms to perform calibration (adjustment) of loadcell.	
16A	BKRL	Brake Release	The brake will forcibly be released.	
17A	RMOD	Operation Mode Switch	The operating mode is selectable when the operation mode switch of the controller is set to AUTO. (The setting is AUTO when signal is OFF, and MANU when ON.)	
18A	HOME	Home Return	The controller will perform home return when this signal is turned ON.	
19A	RES	Reset	Turn the signal ON to reset the alarm.	
20A	SON	Servo ON Command	Turn the signal ON to servo ON. Turn the OFF to Servo OFF.	

\* Select the Parameter No.179.

Pin No.	Category	Signal Abbreviation	Signal Name	Function Description																							
1B	Output	PCMP	Program Finished in Normal Condition	This signal turns ON to show that the press program has finished in normal condition and moved to the standby stage. It is kept on till the next press program execution, axis movement command or servo-OFF command.																							
2B		PRUN	Program Executed	This signal turns ON to show the press program is in execution. "In execution" means from the startup of the program till the end of the standby stage. It does not turn ON while in movement to the program home position.																							
3B		PORG	Program Home Position	This signal turns ON to show the current position is at the program home position of the indicated press program.																							
4B		APRC	While in Approaching the Operation	This signal turns ON to show the approach stage in the press program is in operation.																							
5B		SERC	While in Probing Operation	This signal turns ON to show the probing stage in the press program is in operation.																							
6B		PRSS	While in Pressurizing Operation	This signal turns ON to show the pressurize stage in the press program is in operation.																							
7B		PSTP	Pressurize during the Stop	This signal turns ON to show the stop stage in the press program is in operation.																							
8B		MPHM	Program Home Return during the Movement	This signal turns ON in the following conditions; 1) Program home movement 2) While depressurizing stage in the press program is in operation 3) While returning stage in the press program is in operation 4) While in escape operation to the program home position due to an alarm generated 5) While in escape operation to the program home position due to program compulsory finish																							
9B		JDOK	Judgement OK	Total judgment is made from the values of the position and the load at the end of the judgment period. (The result is maintained till execution of next program.)																							
10B		JDNG	Judgement NG	<table border="1"> <thead> <tr> <th rowspan="2">Signal</th> <th colspan="5">Judgement</th> </tr> <tr> <th>Position OK Load OK</th> <th>Position NG Load OK</th> <th>Position OK Load NG</th> <th>Position NG Load NG</th> <th>Position Invalid Load Invalid</th> </tr> </thead> <tbody> <tr> <td>JDOK</td> <td>ON</td> <td>OFF</td> <td>OFF</td> <td>OFF</td> <td>OFF</td> </tr> <tr> <td>JDNG</td> <td>OFF</td> <td>ON</td> <td>ON</td> <td>ON</td> <td>OFF</td> </tr> </tbody> </table>	Signal	Judgement					Position OK Load OK	Position NG Load OK	Position OK Load NG	Position NG Load NG	Position Invalid Load Invalid	JDOK	ON	OFF	OFF	OFF	OFF	JDNG	OFF	ON	ON	ON	OFF
Signal		Judgement																									
		Position OK Load OK	Position NG Load OK	Position OK Load NG	Position NG Load NG	Position Invalid Load Invalid																					
JDOK		ON	OFF	OFF	OFF	OFF																					
JDNG		OFF	ON	ON	ON	OFF																					
11B		CEND	Loadcell Calibration Completion	Turns ON after loadcell calibration is complete. This signal turns OFF if CLBR signal is turned OFF.																							
12B		RMDS	Operation Mode Status Output	Output the controller operation mode status. This signal turns OFF when the controller is in AUTO Mode, and on when in MANU Mode.																							
13B	HEND	Home Return Completion	This signal will turn ON when home return has been completed. It will be kept ON unless the home position is lost.																								
14B	SV	Servo ON Status Output	This signal will remain ON while the servo is ON.																								
15B	*ALM	Alarm	Turns ON when controller in normal condition, and OFF when alarm is generated.																								
16B	*ALML	Light Failure Alarm	OFF when a message level alarm is generated.																								
17B	-	-																									
18B	-	-																									
19B	0V	N	N	Supply 0V DC power for I/O power																							
20B	0V	N																									

(Reference) signal of active low

Signal with "\*" expresses the signal of active low. Active low signal is an output signal of the type is normally ON in the power-on status and turned OFF at signal output.

• Examples for Connection Circuit

Use the attached cable for the I/O connection.

Model : CB-PAC-PIO□□□ (□□□ indicates the cable length L. Example. 020 = 2m)

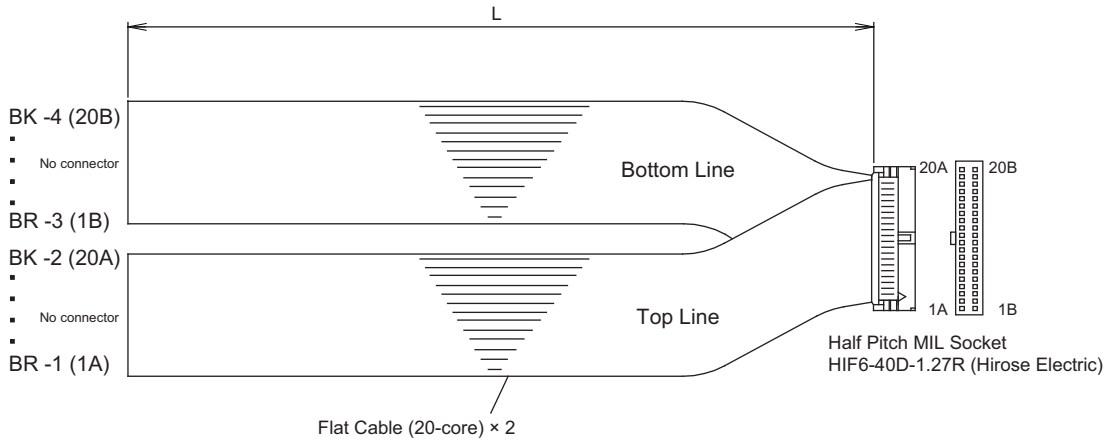

**Caution :** When having a conduction check on the flat cable, make sure not to spread out the inside of the connector female pins. It may cause a contact error and may disable normal operation.

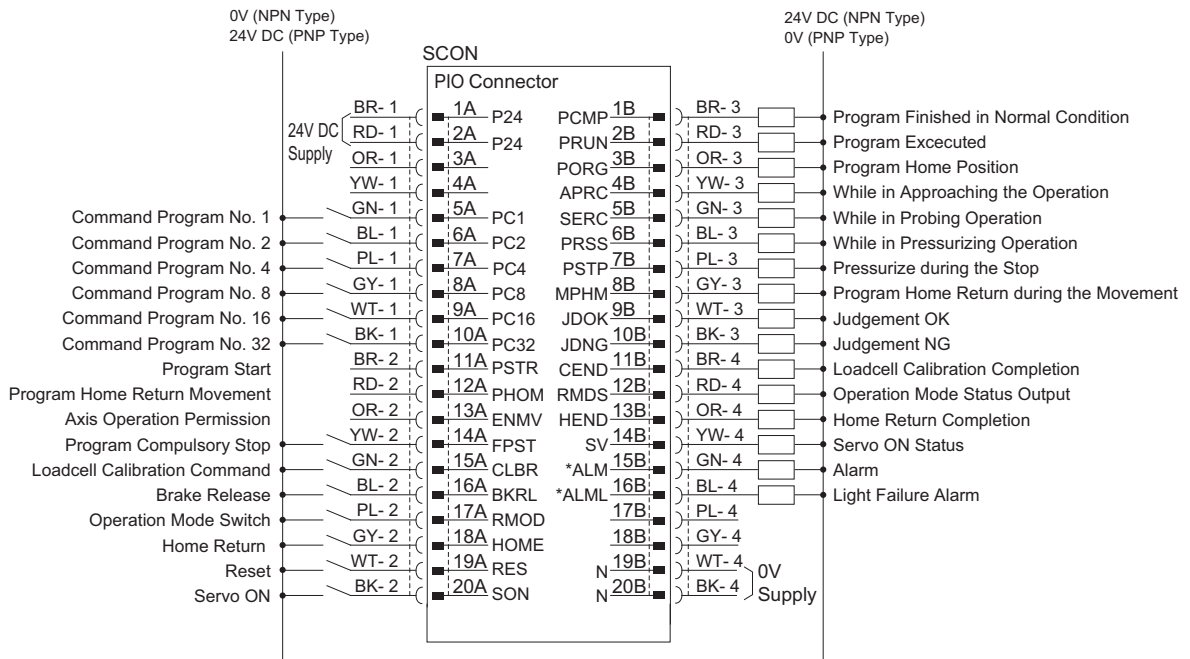

“\*” in codes above shows the signal of the active low. Processing occurs when an input signal of the type is turned OFF. An output signal of the type is normally ON in the power-on status and turned OFF at signal output.

## 2) PIO Circuit for LC/LCG Types

### •List of Control Signal Assignments and Features

The table below shows the signal assignment of the flat cable. Follow the following table connect the external equipment (such as PLC).

Refer to LC Ladder Programming Manual (ME0329) provided separately for how to assign memories in built-in ladder or how to use it.

Pin No.	Category	I/O No.	Signal Name	Function Description	Relevant Sections
1A	24V		Power Supply	Power Supply for I/O +24V	
2A	24V		Power Supply	Power Supply for I/O +24V	
3A	NC			Not used	-
4A					
5A	General Input	IN0	X000	They are 24V general-purposed terminals. Assign to the built-in ladder and use them if necessary.	Refer to LC ladder Programming Manual provided separately
6A		IN1	X001		
7A		IN2	X002		
8A		IN3	X003		
9A		IN4	X004		
10A		IN5	X005		
11A		IN6	X006		
12A		IN7	X007		
13A		IN8	X008		
14A		IN9	X009		
15A		IN10	X00A		
16A		IN11	X00B		
17A		IN12	X00C		
18A		IN13	X00D		
19A		IN14	X00E		
20A	IN15	X00F			
1B	General Output	OUT0	X000	They are 24V general-purposed terminals. Assign to the built-in ladder and use them if necessary.	Refer to LC ladder Programming Manual provided separately
2B		OUT1	X001		
3B		OUT2	X002		
4B		OUT3	X003		
5B		OUT4	X004		
6B		OUT5	X005		
7B		OUT6	X006		
8B		OUT7	X007		
9B		OUT8	X008		
10B		OUT9	X009		
11B		OUT10	X00A		
12B		OUT11	X00B		
13B		OUT12	X00C		
14B		OUT13	X00D		
15B		OUT14	X00E		
16B	OUT15	X00F			
17B	NC			Not used	-
18B					
19B	0V		Power Supply	Power Supply for I/O 0V	
20B	0V		Power Supply	Power Supply for I/O 0V	

## • Examples for Connection Circuit

Use the attached cable for the I/O connection.

Model : CB-PAC-PIO□□□ (□□□ indicates the cable length L. Example. 020 = 2m)

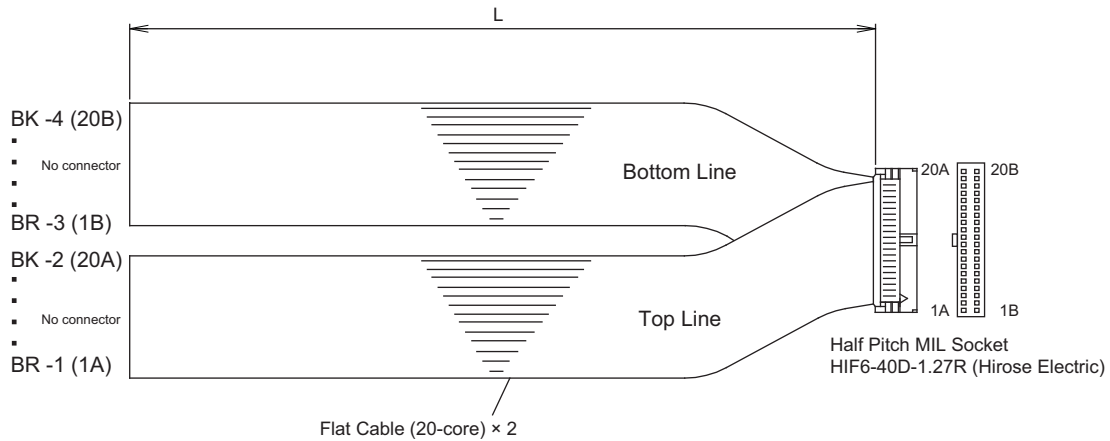

**Caution :** When having a conduction check on the flat cable, make sure not to spread out the inside of the connector female pins. It may cause a contact error and may disable normal operation.

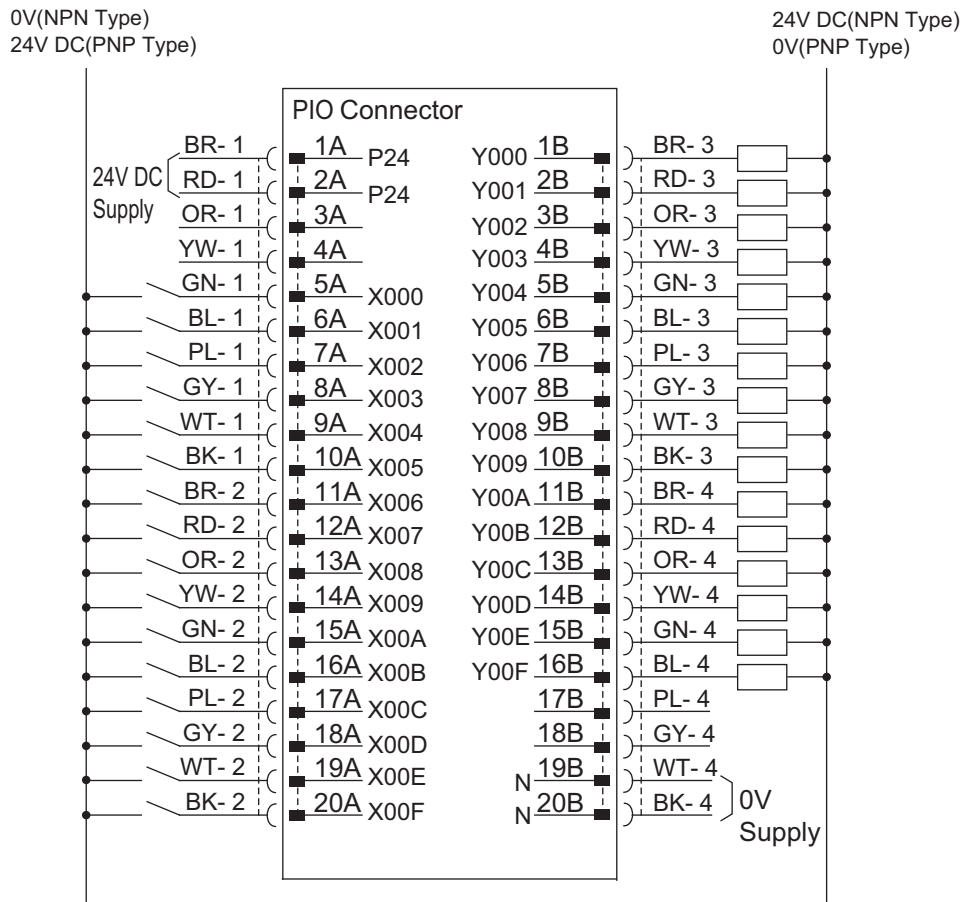

“\*\*” in codes above shows the signal of the active low. Processing occurs when an input signal of the type is turned OFF. An output signal of the type is normally ON in the power-on status and turned OFF at signal output.

[6] Circuit of Regenerative Units

Refer to [3] Actuator Emergency Stop Circuit in this chapter for connection of temperature sensor contact (TM1 and 2).

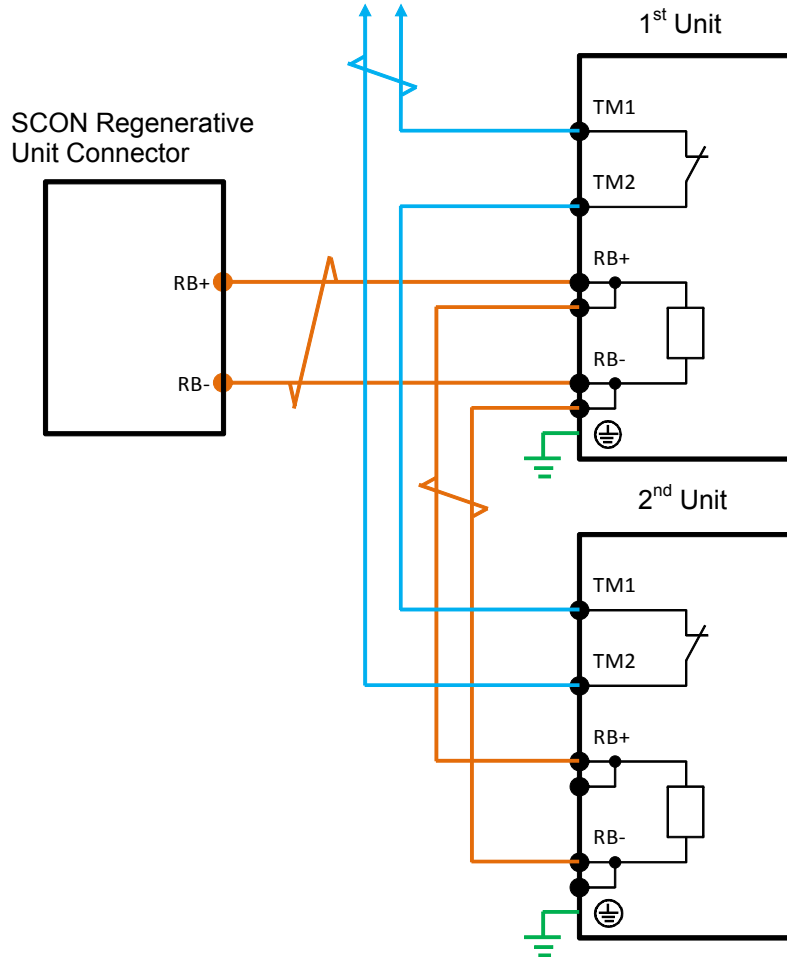

## [7] Multi-function Connector

### 1) When Host Inputting Feedback Pulse with Line Receiver

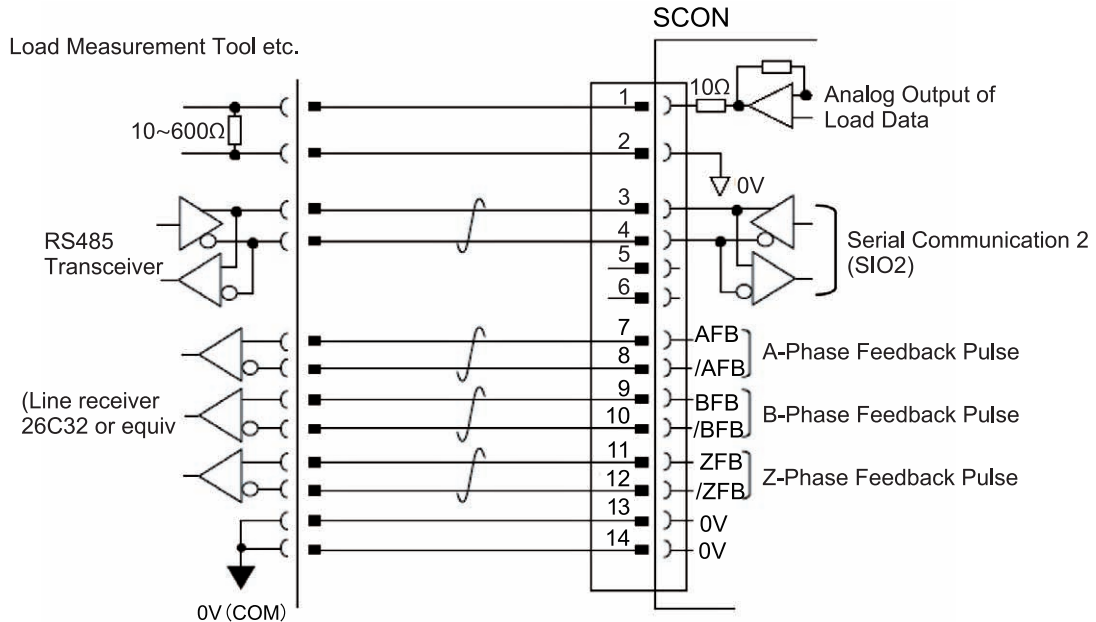

### 2) When Host Inputting Feedback Pulse with Open Collector It is necessary to pulse converter (JM-08 : Option).

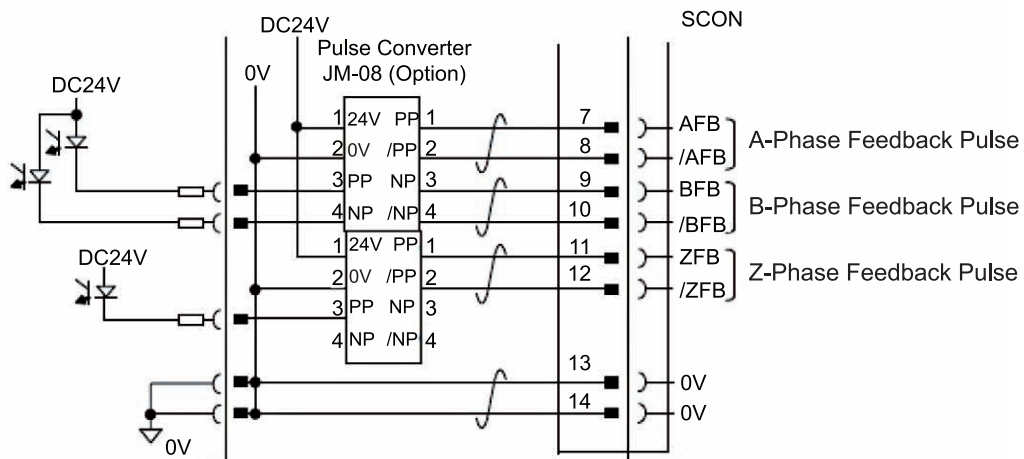

**Caution:** Use the same power source for the positioning unit of the host and JM-08.

## 2.4 Controller for Motors of 3000W and above

\* Refer in Section 2.1 and 2.2 for the controller for motors of to 750W.

### 2.4.1 Wiring for Power Supply Circuit

#### 2.4.1.1 Main Power Circuit (Power Supply Connector)

Power Supply Type	Specifications	Reference
Motor Power Supply	Three-Phase 200 to 230V AC $\pm 10\%$ 50/60Hz	
Control Power Supply	Single-Phase 200 to 230V AC $\pm 10\%$ 50/60Hz	

Supply the power stated below.

The load current will differ depending on the connected actuators and so on. Select and prepare circuit breaker and leakage breaker suitable to the specifications. [Refer to Section 1.3] Also, prepare noise filters and clamp filters referring to the image below.

• Image of Wiring

AC200 to 230V

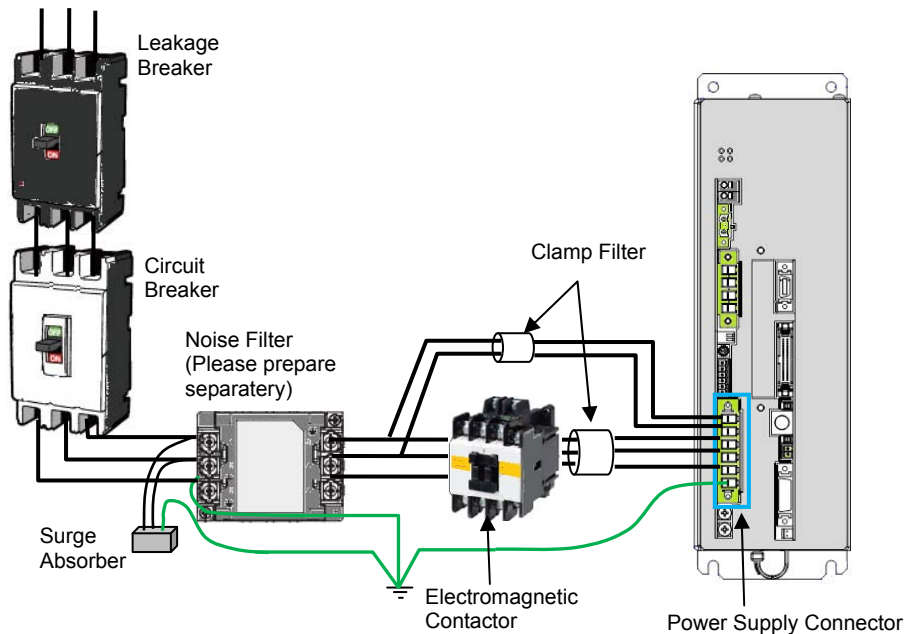

Parts Name	Model	Supplier	Reference
1) Circuit Breaker	For Three-Phase		
2) Leakage Breaker	Three-Phase, for Inverter		
3) Surge Absorber	R·A·V-781BXZ-4	Okaya Electric Industries Co., Ltd.	
4) Noise Filter	TAC-20-683	COSEL	
5) Electromagnetic Contactor	For Three-Phase		
6) Clamp Filter	ZCAT3035-1330	TDK	
7) Power Supply Cable (for Control Power Supply)	AWG18		Rated Voltage at 600V or more Temperature Rating at 60degC or more
8) Power Supply Cable (for Motor Power Supply)	AWG12		
9) Ground Cable	AWG12		

**⚠ Caution:** In case the components stated in the table above are not installed, this controller may cause operation error due to noise influence. Apply these components considering the noise environment and power supply circumstances. It is not compulsory, but is recommended to install them.



● **Wiring Method**

Connect the wiring of power supply to the enclosed connector (Model code: PC5/6-STF-7,62: Phoenix Contact).

See below for how to lay out the power supply wires.

- 1) Loosen the terminal screw with using such as a slotted screwdriver to open up the inlet.
- 2) Reveal the sheath for 10mm on the cable that satisfies the cable diameter complies the specification shown in the table below and put it in the inlet.
- 3) Tighten the terminal screw with using such as a slotted screwdriver. The inlet closes and affixes the wire.
- 4) Connect all the wires in the same manner and insert the enclosed connector to the power connector.

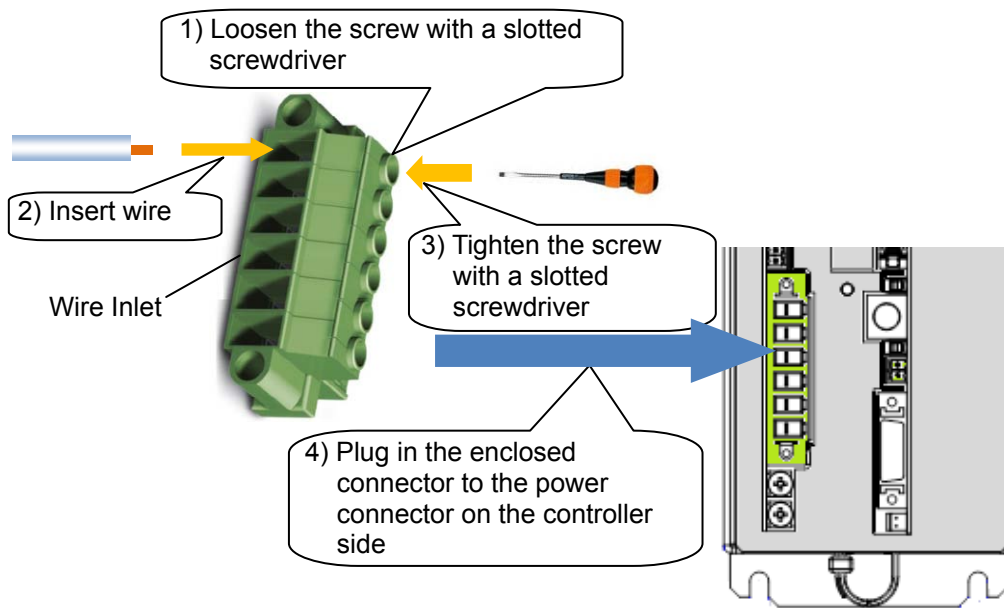

Power supply connector (PWR)

Pin No.	Signal name	Items	Applicable cable diameter
1	L1C	Control power AC input	0.75mm <sup>2</sup> (AWG18)
2	L2C		
3	L1	Motor power AC input	3.3mm <sup>2</sup> (AWG12)
4	L2		
5	L3		
6	PE	Protective grounding wire	3.3mm <sup>2</sup> (AWG12)

## 2.4.1.2 Brake Power Supply (Brake Power Connector)

Supply 24V DC  $\pm 10\%$  and 0.1A at maximum to the controller and 24V DC  $\pm 10\%$  and 1.5A at maximum to the actuator when an actuator equipped with a brake is used.

- Image of Wiring

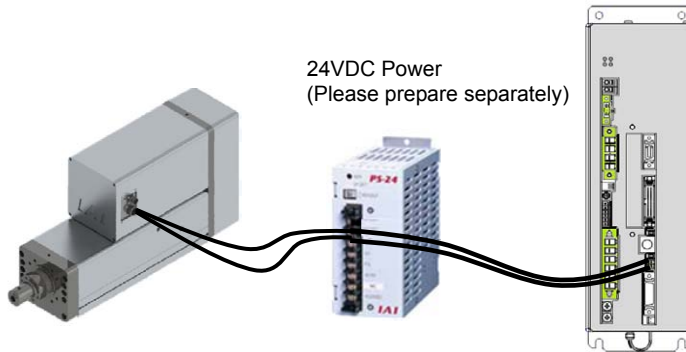

- Wiring Method

Connect the power supply to the enclosed connector\* (Model code: MC1.5/2-ST-3.5: Phoenix Contact).

\* Controller side : Model code : MC1.5/2-ST-3.5: Phoenix Contact

Actuator side : Model code : FMC1.5/3-STF-3.5: Phoenix Contact

See below for how to lay out the power supply wires.

- 1) Loosen the terminal screw with using such as a slotted screwdriver to open up the inlet.
- 2) Reveal the sheath for 7mm (controller side) and 10mm (actuator side) on the cable that satisfies the cable diameter complies the specification shown in the table below and put it in the inlet.
- 3) Tighten the terminal screw with using such as a slotted screwdriver. The inlet closes and affixes the wire.
- 4) Connect all the wires in the same manner and insert the enclosed connector to the power connector.

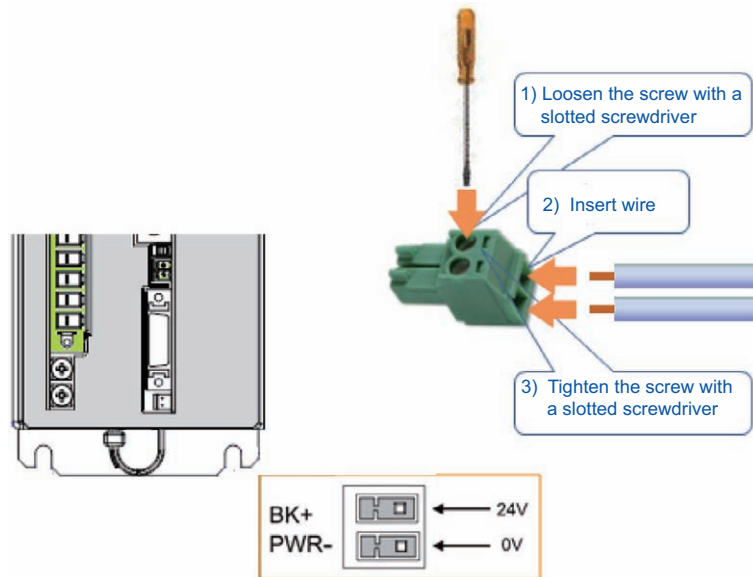

Brake Power Supply Connector

Pin No.	Signal name	Items	Applicable cable diameter
	BK+	24V DC power input	1.25 to 0.5mm <sup>2</sup> (AWG16 to 20)
	PWR-	24V DC ground	

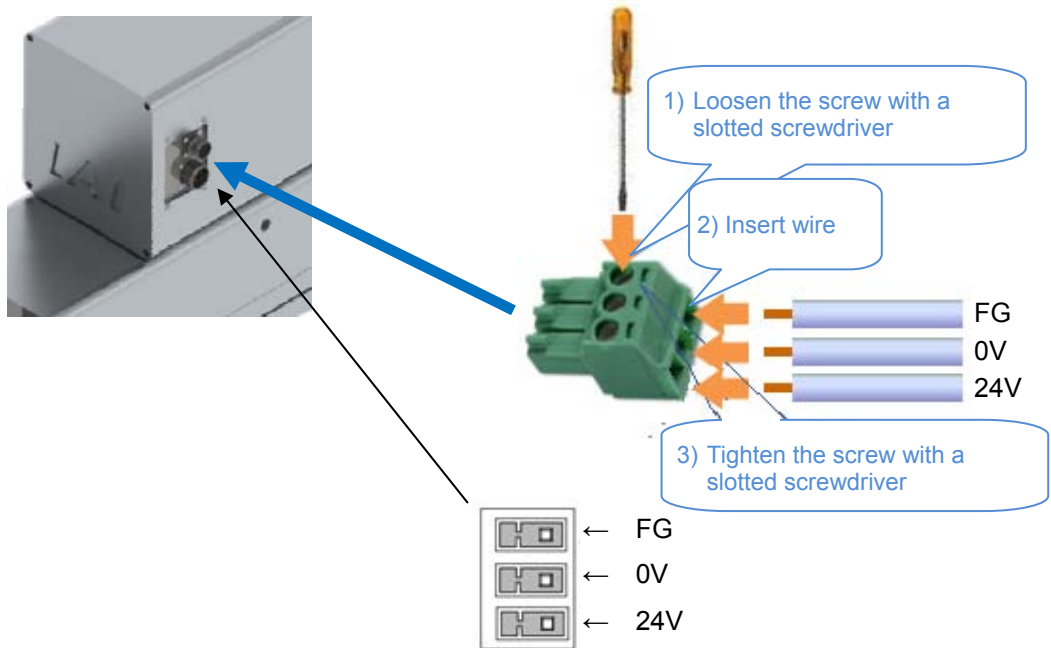

Brake Power Supply Connector

Pin No.	Signal name	Items	Applicable cable diameter
	FG	Frame ground	1.25 to 0.5mm <sup>2</sup> (AWG16 to 20)
	0V	24V DC ground	
	24V	24V DC power input	

## 2.4.2 Wiring of Emergency Stop Circuit (System I/O)

Make sure to construct the wiring of the emergency stop circuit considering the suitability to the Safety Category of the whole system.

- Image of Wiring

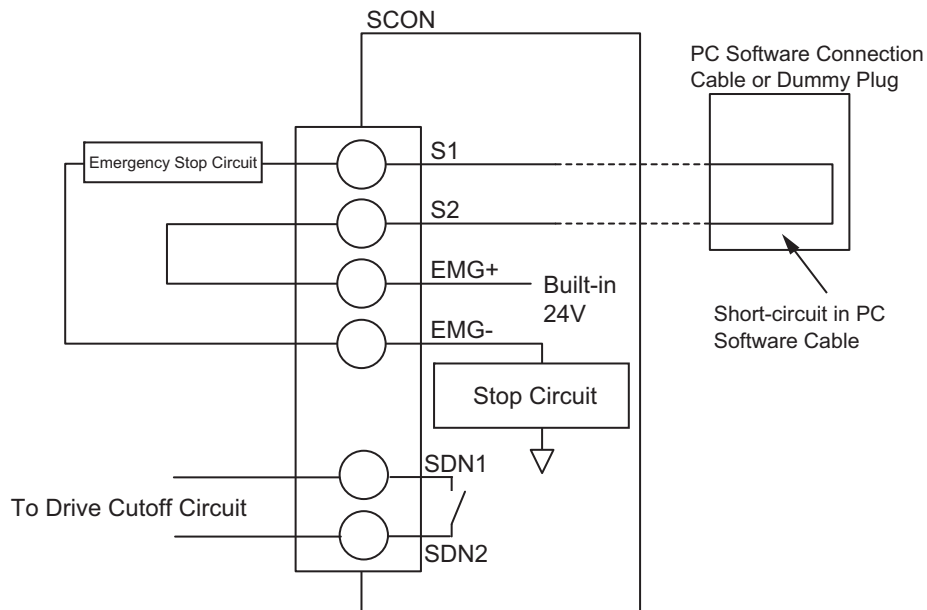

- Note 1 It is not equipped with a relay that automatically identifies that a teaching tool was inserted and switches over the wiring layout. Connect a dummy plug to the SIO connector in normal operations.
- Note 2 Construct the circuit considering the safety category of the whole equipment.
- Note 3 Make sure to construct the emergency stop circuit using the built-in 24V (EMG+ Terminal) output for EMG- Terminal.
- Note 4 As it is not equipped with the built-in motor drive cutoff relay, it is necessary to establish external drive cutoff.

### For the SDN terminal (Drive cutoff contact output)

#### SDN1, SDN2

- It is the contact output to control the drive cutoff device connected externally.
- Configure the circuit in such a way that the drive source will never be turned on when these contacts are open.  
When turning on the power, turn on the control power first, confirm that these contacts are closed, and then turn on the drive power.
- The rating of this contact is 30V Max. / 200mA Max.

#### Conditions to Open SDN Contact

- 1) At stop signal input (when the dry contact connected between EMG+ and EMG- is open)
- 2) When an alarm is generated (Cold start level)
- 3) In disable condition

● **Wiring Method**

Connect the wiring of operation stop (system I/O connector) to the enclosed connector (Model code: FMC1.5/6-ST-3.5: Phoenix Contact).

See below for how to lay out the power supply wires.

- 1) Loosen the terminal screw with using such as a slotted screwdriver to open up the inlet.
- 2) Reveal the sheath for 7mm on the cable that satisfies the cable diameter complies the specification shown in the table below and put it in the inlet.
- 3) Tighten the terminal screw with using such as a slotted screwdriver. The inlet closes and affixes the wire.
- 4) Connect all the wires in the same manner and insert the enclosed connector to the power connector.

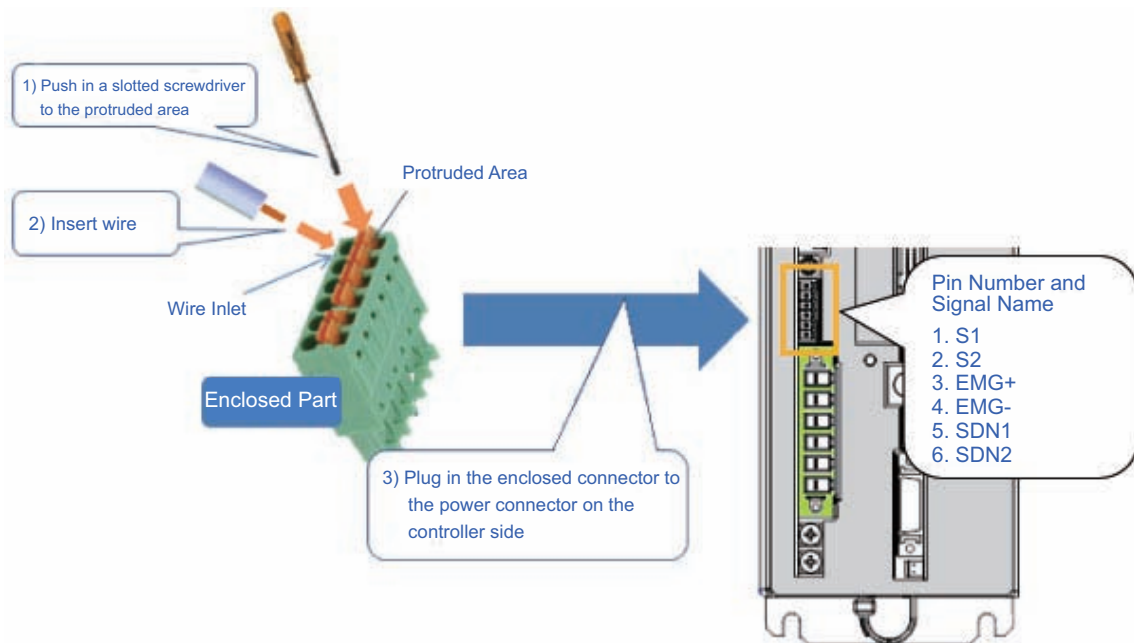

System I/O connector

Pin No.	Signal name	Items	Applicable cable diameter
1	S1	Operation stop switch contact	1.25 to 0.5mm <sup>2</sup> (AWG16 to 20)
2	S2	Operation stop switch contact	
3	EMG+	Operation stop dedicated power output	
4	EMG-	Operation stop input	
5	SDN1	Drive cutoff contact output	
6	SDN2	Drive cutoff contact output	

### 2.4.3 Connection of Actuator

Connect the motor cable to the MOT connector.  
 Connect the encoder cable to the PG connector.

- Image of wiring

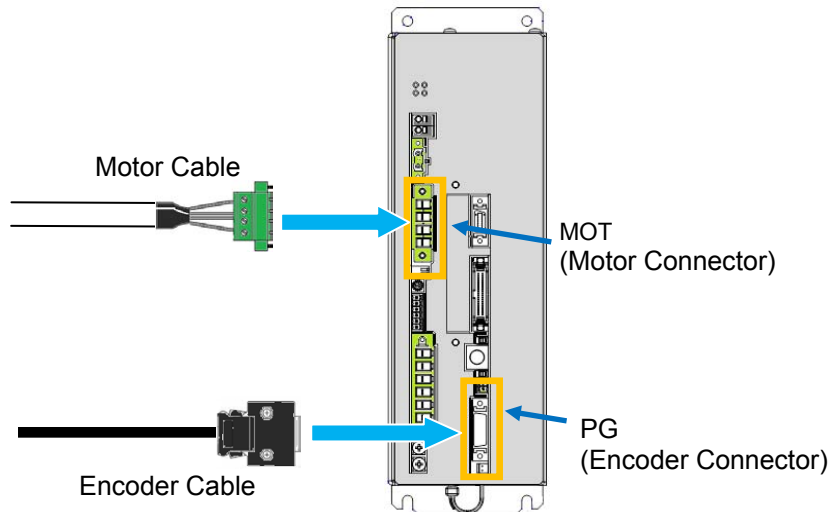

**⚠ Caution :** For Absolute Type, remove the absolute battery connector from the controller before connecting the encoder cable.

**Motor Connector (MOT)**

	Model	Remarks
Cable Side	IPC5/4-STF-7.62	
Controller Side	IPC5/4-GF-7.62	

Pin No.	Signal name	Items	Applicable cable diameter
1	PE	Protective grounding wire	Dedicated cable for IAI actuator
2	U	Motor drive U-phase	
3	V	Motor drive V-phase	
4	W	Motor drive W-phase	

**Encoder Connector (PG)**

	Model	Remarks
Cable Side	10126-3000PE	
Controller Side	10226-6202JL	

Pin No.	Signal name	Items	Applicable cable diameter
1	A+	Phase A Difference + Input (Phase U+)	Cable dedicated for IAI encoders
2	A-	Phase A Difference - Input (Phase U-)	
3	B+	Phase B Difference + Input (Phase V+)	
4	B-	Phase B Difference - Input (Phase V-)	
5	Z+	Phase Z Difference + Input (Phase W+)	
6	Z-	Phase Z Difference - Input (Phase W-)	
7	SRD+	Send/Receive Difference + (Pulse/Magnetic Pole Changeover +)	
8	SRD-	Send/Receive Difference - (Pulse/Magnetic Pole Changeover -)	
9	LC_SRD+	Loadcell Communication +	
10	LC_SRD-	Loadcell Communication -	
11	NC	Unconnected	
12	E24V	Sensor Power Output	
13	0V	24V Power Supply GND	
14	BAT+	Backup Battery Power Supply	
15	BAT-	Battery Ground	
16	VCC	Encoder Power	
17	GND	GND	
18	LC_VCC	Loadcell Power +	
19	LC_GND	Loadcell Power -	
20	BKR-	Brake Release Output Signal - (COM : Common to All Axes)	
21	BKR+	Brake Release Output Signal +	
22	NC	Unconnected	
23	RSV	Sensor Input (Reserve)	
24	OT	Sensor Input (Over Travel)	
25	CREEP	Sensor Input (Creep sensor)	
26	LS	Sensor Input (limit switch)	

### 2.4.4 Connection of PIO

For the signal assignment of each wire, refer to the following considering the operation mode.

- Image of wiring

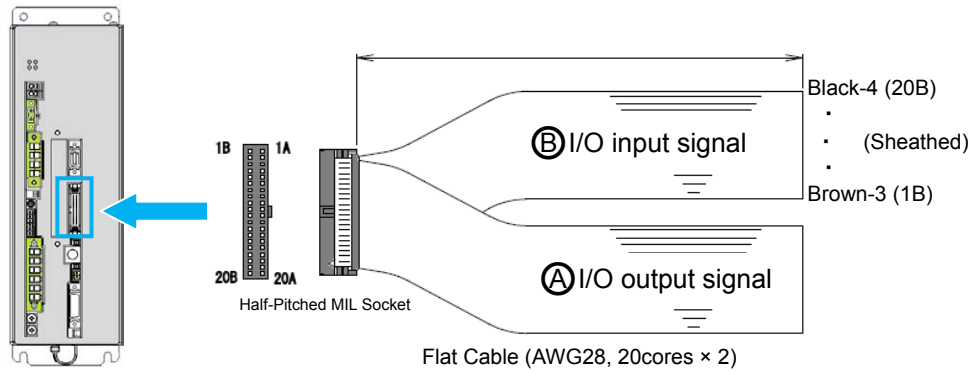

\* Indicate the enclosed I/O cable length in "m" unit in the controller model code.  
 (MAX. 5m)  
 Up to 10m is available at maximum with separate sold option.  
 (Model: CB-PAC-PIO□□□: □□□ is cable length L e.g. 020 = 2m)

No.	Cable Color	Wiring	No.	Cable Color	Wiring
1A	BR-1	Flat Cable (A) (Solderless) AWG28	1B	BR-3	Flat Cable (B) (Solderless) AWG28
2A	RD-1		2B	RD-3	
3A	OR-1		3B	OR-3	
4A	YW-1		4B	YW-3	
5A	GN-1		5B	GN-3	
6A	BL-1		6B	BL-3	
7A	PL-1		7B	PL-3	
8A	GY-1		8B	GY-3	
9A	WT-1		9B	WT-3	
10A	BK-1		10B	BK-3	
11A	BR-2		11B	BR-4	
12A	RD-2		12B	RD-4	
13A	OR-2		13B	OR-4	
14A	YW-2		14B	YW-4	
15A	GN-2		15B	GN-4	
16A	BL-2		16B	BL-4	
17A	PL-2		17B	PL-4	
18A	GY-2		18B	GY-4	
19A	WT-2		19B	WT-4	
20A	BK-2		20B	BK-4	

- Wiring Method

Conduct the connection of I/O to the controller is to be carried out using the dedicated I/O cable. Cable length is to be indicated in the controller model code. Please check the controller model code. A desired I/O cable can be selected from 2m (standard), 3m, and 5m cables. Up to 10m I/O cables are sold separately.



## 2.4.5 Multi-function Connector

The multi-function connector is equipped with following interfaces.

- 1) Analog output of load data
- 2) Feedback pulse output
- 3) Serial communication port 2 (SIO2)

### [1] Image of wiring

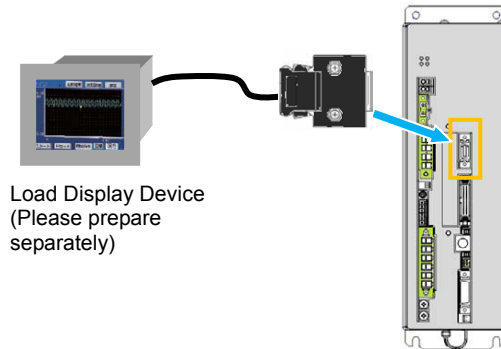

### [2] Multi-function connector (MF I/F)

Item	Items and Model	
Connector Name	Multi-function connector (MF I/F)	
Cable Side	10114-3000PE (3M)	
Controller Side	10214-52A2PL (3M)	

Pin No.	Signal name	Items	Applicable cable diameter
1	IOUT	Load data detected at loadcell is output as analog data (current)	0.2mm <sup>2</sup> (AWG24)
2	GND		
3	SD+	SIO communication line for display device For display of each data	
4	SD-		
5	-	Not used	
6	-		
7	AFB	Feedback pulse (+A)	
8	/AFB	Feedback pulse (-A)	
9	BFB	Feedback pulse (+B)	
10	/BFB	Feedback pulse (-B)	
11	ZFB	Feedback pulse (+Z)	
12	/ZFB	Feedback pulse (-Z)	
13	GND	0V (For feedback pulse)	
14	GND	0V (For SIO communication line)	

## [3] Wiring Method

**⚠ Caution: Enclosed only in plug and shell.  
Do the same wiring layout as the following option.**

Connect the multi-function connector to the enclosed connector (Model: 10114-3000PE). See below for how to lay out the power supply wires.

- 1) Prepare a cable.  
(Multiple twisted pair shielded cable with AWG24 (0.2mm<sup>2</sup>) or cable enclosed in the connected unit (host side))
- 2) Solder to the connector directly.  
Pay attention not to have short circuit with a terminal next to it by having pretinning and so on.

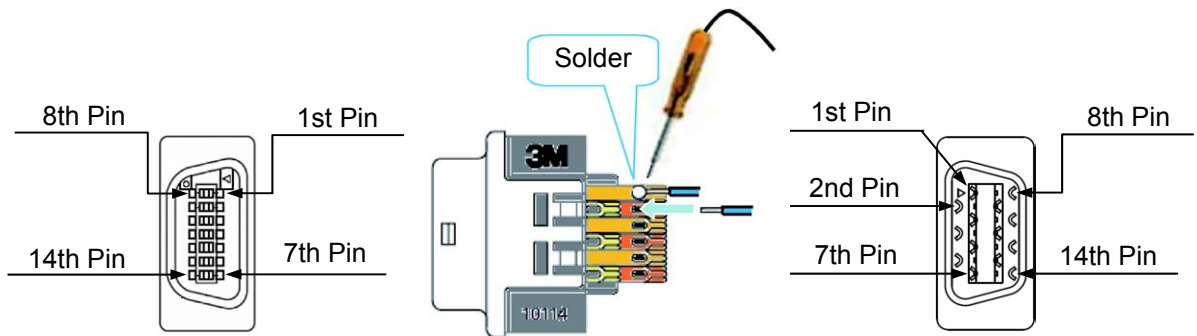

## [4] Connector with Cable (Option)

Model: CB-SC-PIOS□□□ □□□ is cable length: e.g. 020 = 2m  
Cable length: For differential system, MAX. 10m  
For open collector, MAX. 2m

(Note) There is no connector equipped on the host controller (PLC, etc.) side. Make an appropriate treatment that suits the host controller (PLC, etc.). Also, to prevent the noise influence as much as possible, make the cable as short as possible.

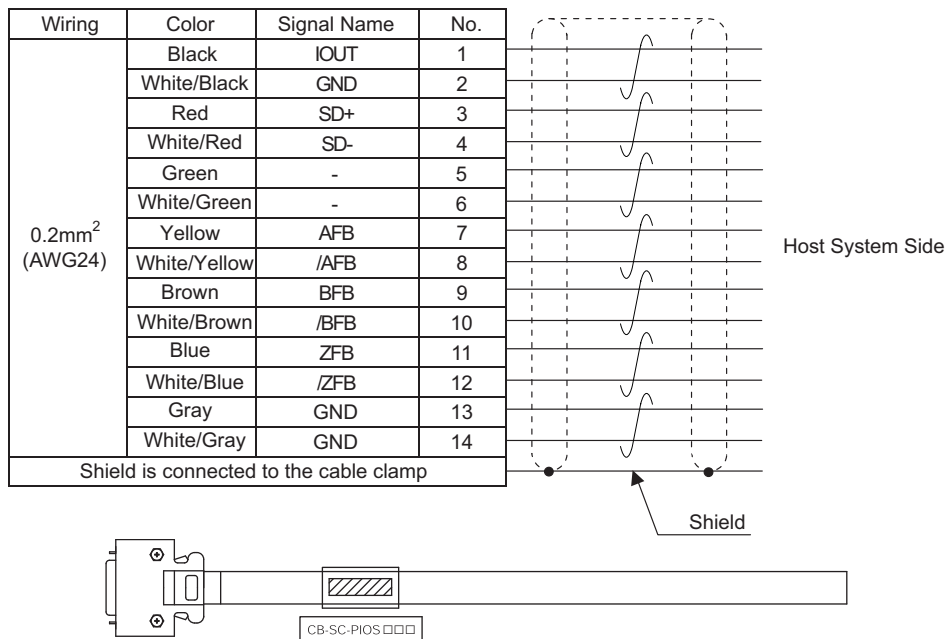

[5] Pulse Converter: JM-08

The pulse converter converts command pulses in the those in the differential mode to open collector mode.

Use this converter if the host controller sends output pulses in the applicable for open collector (24V type).



**Caution :**

- 1) Pay attention not to insert wrongly because it is the same e-CON connector as input and output. Putting the power on with the insertion being wrong will burn JM-08.
- 2) Use the pulse converter in the ambient temperature range between 0°C to 40°C.
- 3) The temperature increase of about 30°C occurs during operation. Accordingly, neither install several pulse converters in close contact nor install them within a duct. Do not install the pulse converter near other heating devices.
- 4) If more than one pulse converters are installed, set a pulse converter apart from another by 10mm or more.
- 5) Make the wiring between the host controller (PLC etc.) and JM-08 as short as possible.  
Long wires make it easy to pick up noise. Also make the wiring between JM-08 to SCON controller as short as possible. Place JM-08 close to the host controller.

A recommended installation sample is shown in the figure below.

- Make the cable length between the host controller and pulse converter as short as possible.

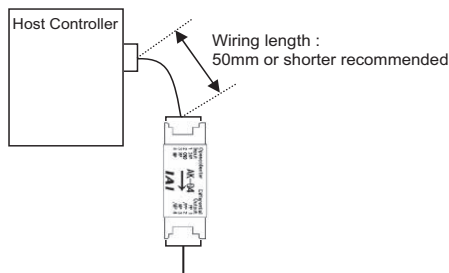

- Keep pulse converters separated for 10mm or more from each other.

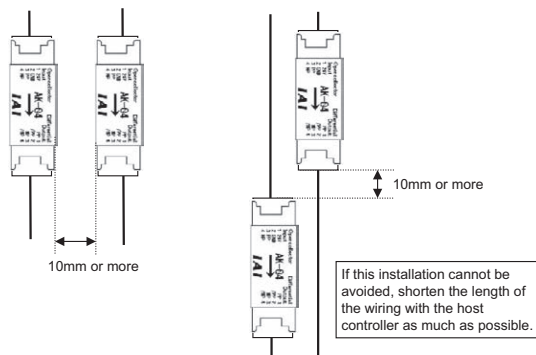

## 2.4.6 Connection of Regenerative Unit

Lay out necessary number of regenerative units.

- Image of wiring

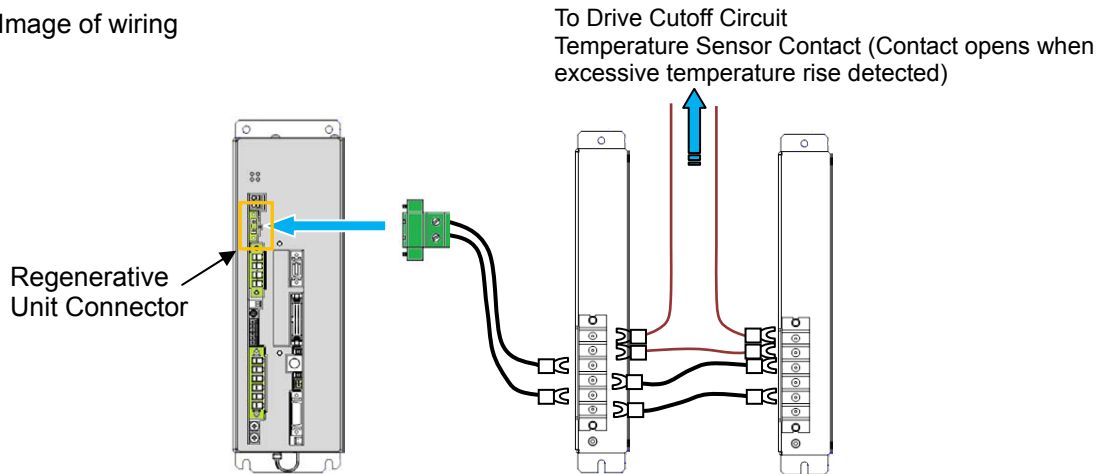

- [Reference for the number of connected units]

Actuator Model	Cycle Time [sec]	Number of Connected Regenerative Units [units]
RCS3-RA15R (3t type)	2.5 or more	0 (Not necessary)
	Less than 2.5	1
RCS3-RA20R (5t type)	12 or more	0 (Not necessary)
	6 or more less than 12	1
	3.5 or more less than 6	2
	Number less than 3.5 not available for setting	

The number of connectable units is the same regardless of the orientation of the actuator installation (horizontal / vertical).

The number of connectable regenerative units is two units at the maximum. In case "OCA" overheat alarm gets generated even with two units connected, adjust the operational conditions such as to make the standby duration longer or to make the velocity lower.

- Caution :**
- 1) Connecting three regenerative unit or more will cause malfunction.
  - 2) Do not attempt to touch the regenerative units during use as the temperature gets very high.
  - 3) Do not install them near a flammable object.
  - 4) It is recommended to use cables with high heat resistance performance. Also, consider wire layout so the cables would not touch the regenerative units.
  - 5) The unit is equipped with a built-in temperature sensor. Establish the circuit constructed to cut off the power source when the temperature sensor is in operation.
  - 6) The number of connected units in the table is a reference for when a work piece of 10kg is mounted and the standby duration is set to 1 second.

● **Wiring Method**

Connect the wiring of the enclosed connector (Model code: GIC2,5/2-STF-7,62: Phoenix Contact). See below for how to lay out the power supply wires.

- 1) Loosen the terminal screw with using such as a slotted screwdriver to open up the inlet.
- 2) Reveal the sheath for 7mm on the cable that satisfies the cable diameter complies the specification shown in the table below and put it in the inlet.
- 3) Tighten the terminal screw with using such as a slotted screwdriver. The inlet closes and affixes the wire.
- 4) Connect all the wires in the same manner and insert the enclosed connector to the power connector.

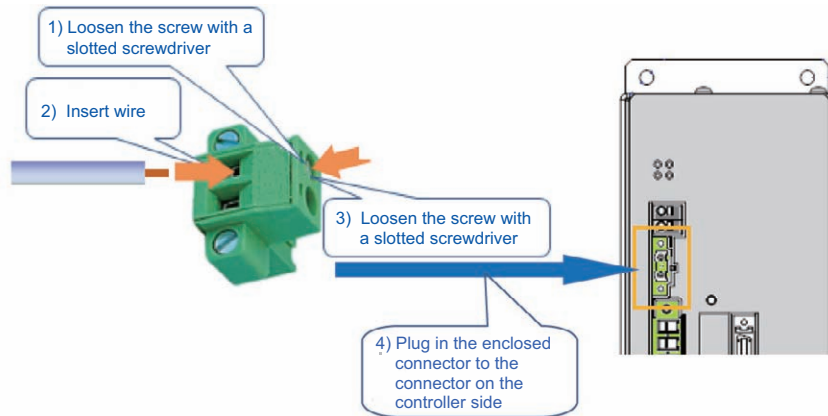

**Specifications of Connector Part Connected to External Regenerative Unit on Controller Side**

Item	Items and Model	
Connector Name	External Regenerative Unit Connector (RB)	
Cable Side	GIC2,5/2-STF-7,62	
Controller Side	GIC2,5/2-GF-7,62	

Pin No.	Signal name	Items	Applicable cable diameter
/	RB+	Regenerative Resistor +	0.75mm <sup>2</sup> (AWG18) Use copper conductive wires with rated voltage at 600V or more and temperature rating at 60degC or more.
/	RB-	Regenerative Resistor -	

● **Wiring on Regenerative Unit Side**

Perform wiring with crimping a conforming cable described below to an M4 solderless terminal.

**Specifications for External Regenerative Unit Connection Terminal Block**

Item	Specification
Terminal Screw	M4
Applicable Cable Diameter	AWG18
Tightening Torque	1.2Nm

Pin No.	Signal name	Items	Applicable cable diameter
/	TM1	Temperature Sensor Contact (N.C.)	0.75mm <sup>2</sup> (AWG18) Use copper conductive wires with rated voltage at 600V or more and temperature rating at 60degC or more.
/	TM2	Temperature Sensor Contact (N.C.)	
/	RB+	Regenerative Resistor +	
/	RB+	Regenerative Resistor +	
/	RB-	Regenerative Resistor -	
/	RB-	Regenerative Resistor -	

### 2.4.7 SIO Connector Connection

SIO connectors can be used not only for the connection of teaching tool, but also for the connection of the host controller (PLC, touch panel and PC).

For the operation, refer to the instruction manual of each module.

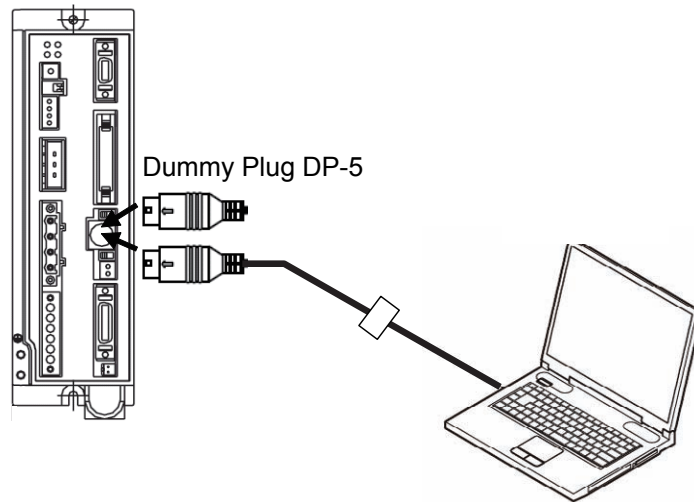

Item	Items and Model	
Connector Name	SIO Connector	
Cable Side	miniDIN 8 Pin	
Controller Side	TCS7587-0121077	

Pin No.	Signal name	Items	Applicable cable diameter
1	SGA	Teaching tool signal+	Dedicated connection cables provided by us
2	SGB	Teaching tool signal-	
3	5V	Power supply for teaching tool	
4	ENB	Enable signal input	
5	EMGA	Emergency stop signal A	
6	24V	Power supply for teaching tool	
7	0V	0V	
8	EMGB	Emergency stop signal B	
Shell	0V	0V	

**⚠ Caution :** If the controller is connected with a teaching device, set the operation mode setting switch to MANU.  
 Removing the SIO connector while the power is ON causes a transient emergency stop. Thus, the devices such as the actuator which are in operation will stop.  
 Do not disconnect the SIO connector during the operation.  
 In case the SIO connector is not used, make sure to insert the dummy plug DP-5 for teaching pendant.

## Chapter 3 Operation

**⚠ Caution :** For SCON-LC/LCG Types, get knowledge for how to operate in this chapter, and see Ladder Programming Manuals [ME0329 and ME0330] provided separately.

### 3.1 Explain the Operation Mode and Setting

#### 3.1.1 Power Supply and Cutoff

(1) Procedure to Supply Power

The procedure described below is for the case the parameters are in the setting conducted before delivery and not in error generated or emergency stop condition.

- 1) After confirming the wiring is conducted properly, supply power to peripheral devices (such as PIO and fieldbus) first in case they are installed.
- 2) Supply control power.
- 3) Supply motor drive power.

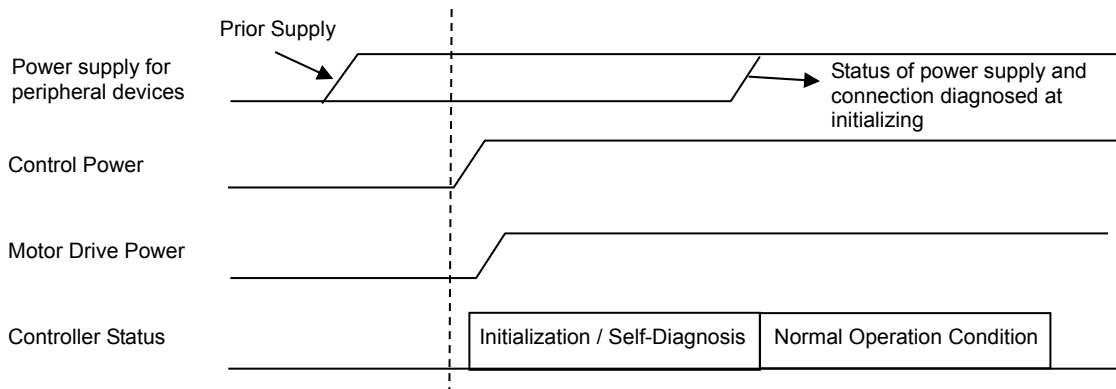

(Note) Supply control power and motor power at the same time or control power first.  
Supply motor drive power within 1sec after supplying the control power. An alarm will be generated if passed 1sec or more.

(2) Procedure to Shut off Power

Have a procedure in the reversed order from supplying the power.

(Note) There may be a case that the power error and the control power voltage drop could occur at power shutoff, but it is not an error.

### 3.1.2 Explain the Operation Mode

[1] What is Servo Press

Pressing direction is only the direction to press towards the work piece.

⚠ Caution : Pressing direction is only the direction to press towards the work piece. It is not applicable for pulling against the work piece.

Desired pressing operation can be easily realized with fine-tuning of pressurizing force, speed, etc. This controller is used with combination from two types of pressurizing modes and four types or five types of stopping systems.

No.	Pressurize Mode	Stopping System	Stop Status
1)	Speed Control	Potition Stop	Positioning Stop
2)		Distance Stop	
3)		Load Stop	
4)		Incremental Load Stop	
5)	Force Control	Potition Stop	Pressing Operation Continued
6)		Distance Stop	
7)		Load Stop	
8)		Incremental Load Stop	
9)		Potition Stop 2	

⚠ Caution : The speed control mode and and position stop 2 of the above 9) conducts the positioning at the set position. Therefore, the position after pressurizing is constant, but the pressing force may not be stable.  
The force control mode except for the position stop 2 above 9), conducts the pressing at the set load as target pressing force. Therefore, the pressing force after pressurizing is constant, but the position may not be stable.

#### 1) Sppeed Control Position Stop

With the position set in pressurizing condition as the target position, movement is conducted forward (press) with the pressurizing speed kept constant. After reaching the set position, stops with the position kept constant.

Even if the load fluctuates while moving forward, the speed is kept as constant as possible. It should be used in the pressing operation that requires a stop after movement in the indicated distance.

\* Program alarm gets generated when reached the maximum load.

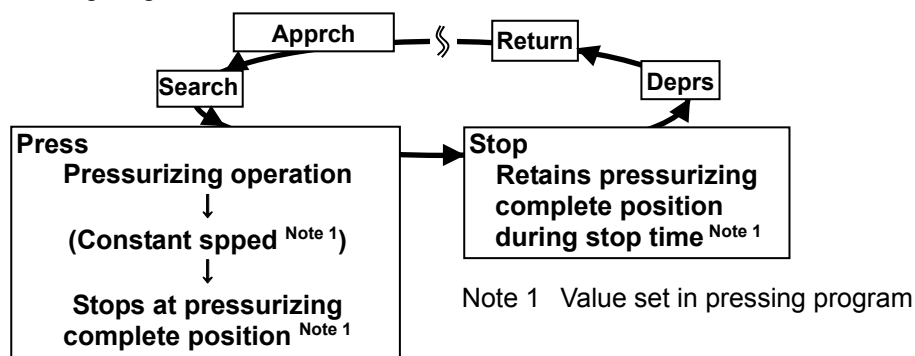



**2) Spped Control Distance Stop**

With the position set in pressurizing condition as the target distance, movement is conducted forward (press) with the pressurizing speed kept constant. After moving forward for the set distance, stops with the position kept constant. Even if the load fluctuates while moving forward, the speed is kept as constant as possible. It should be used in the pressing operation that requires a stop after movement in the indicated distance even if the pressurizing start position may change.  
 \* Program alarm gets generated when reached the maximum load.

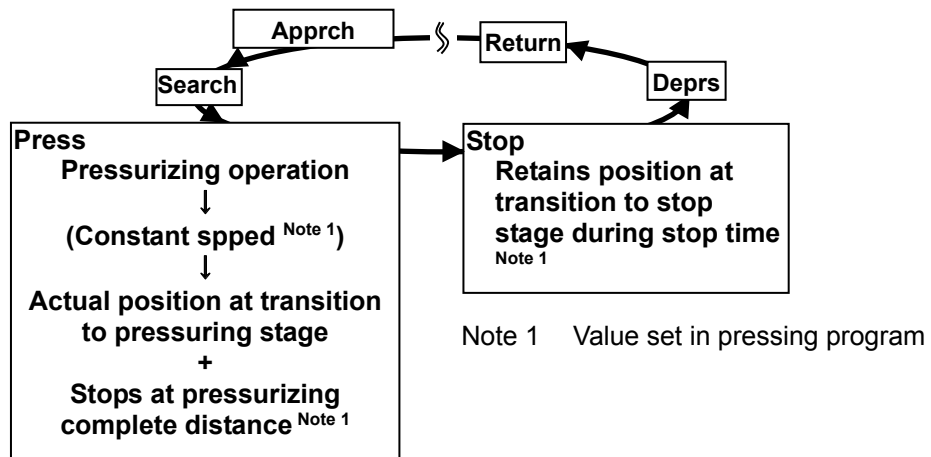

**3) Spped Control Load Stop**

It moves forward till detecting the load that setting load, and the movement is conducted forward (press) with the pressurizing speed kept constant till detection. After detecting the setting load, it stops with the position kept constant. Even if the load fluctuates while moving forward, the speed is kept as constant as possible. It should be used in the pressing operation that requires a stop at the position that the indicate load detected.  
 \* Program alarm gets generated when reached the pressurizing limit position.

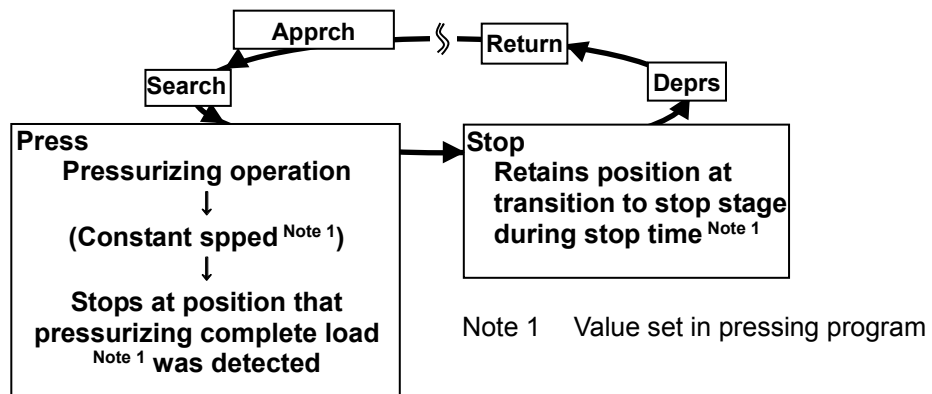

**4) Sppeed Control IncrementalLoad Stop**

It moves forward till detecting the load that incremental load set in the pressurizing condition is added to the pressurizing start load, and the movement is conducted forward (press) with the pressurizing speed kept constant till detection. After detecting the added load, it stops with the position kept constant.

Even if the load fluctuates while moving forward, the speed is kept as constant as possible. It should be used in the pressing operation that requires a stop at the position that the load that the set incremental load is added to the pressurizing start load is detected.

\* Program alarm gets generated when reached the pressurizing limit position.

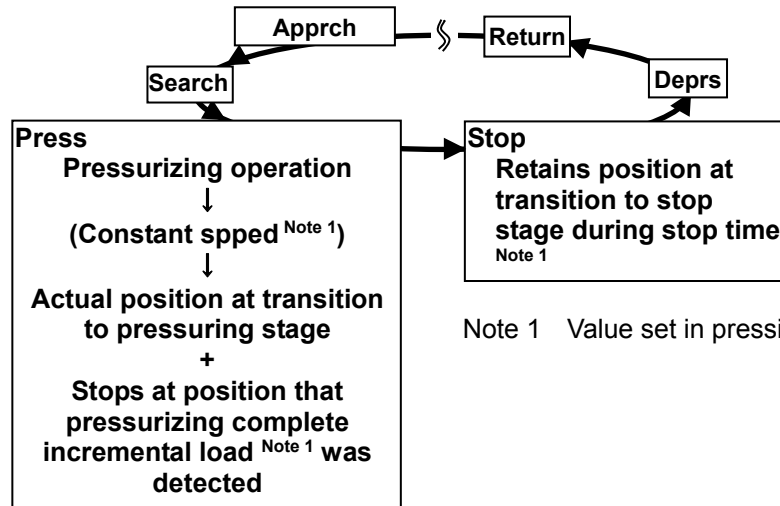

Note 1 Value set in pressing program

**5) Force Control Position Stop**

With the position set in pressurizing condition as the target position, movement is conducted forward (press) with the pressurizing speed kept constant up to set position (Note 1). With the load at the time of reaching the set position as the target load, stop (Note 2) is conducted with the pressing force kept constant.

\* Program alarm gets generated when reached the maximum load at pressurizing. The program alarm also gets generated when the position exceeded the range of  $\pm 0.1\text{mm}$  at transition to stop stage.

Note 1: After transitioned to the force control, pressurizing speed would not be constant.

(The condition of transition is to be set in Parameter No. 173 Force Control Transition Threshold)

Note 2: When a subject to be pressed (work piece) has moved away, the actuator chases for 0.1mm at maximum. Therefore, the actual stop position may exceed 0.1mm at maximum from the set position.

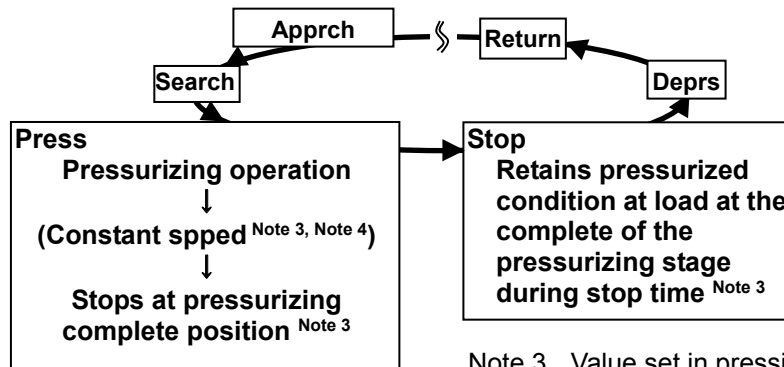

Note 3 Value set in pressing program

Note 4 The velocity may not be constant during the force control.

**6) Force Control Distance Stop**

With the position set in pressurizing condition the target distance, movement is conducted forward (press) with the pressurizing speed kept constant up to set position (Note 1). With the load at the time that moving forward for the set distance is complete as the target load, stop (Note 2) is conducted with the pressing force kept constant. It should be used in the pressing operation that requires a stop in detection load of after movement position in the indicated distance even if the pressurizing start position may change.

\* Program alarm gets generated when reached the maximum load at pressurizing. The program alarm also gets generated when the position exceeded the range of  $\pm 0.1\text{mm}$  at transition to stop stage.

Note 1: After transitioned to the force control, pressurizing speed would not be constant.  
(The condition of transition is to be set in Parameter No. 173 Force Control Transition Threshold)

Note 2: When a subject to be pressed (work piece) has moved away, the actuator chases for 0.1mm at maximum. Therefore, the actual stop position may exceed 0.1mm at maximum from the set position.

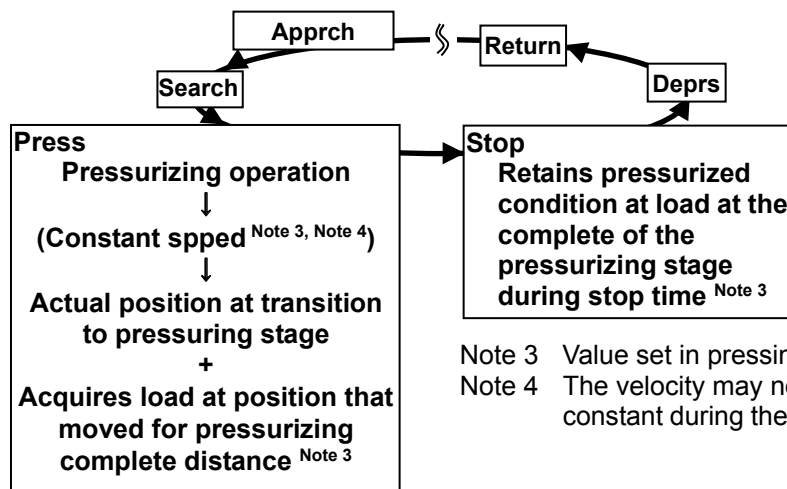

**7) Force Control Load Stop**

With the position set in pressurizing condition the target distance, movement is conducted forward (press) with the pressurizing speed kept constant up to set position (Note 1). Stop is conducted with the pressing force kept constant so it reaches the target load. It should be used in the pressing operation that requires a stop at the position that the indicate load detected.

\* Program alarm gets generated when reached the pressurizing limit position.

Note 1: After transitioned to the force control, pressurizing speed would not be constant.  
(The condition of transition is to be set in Parameter No. 173 Force Control Transition Threshold)

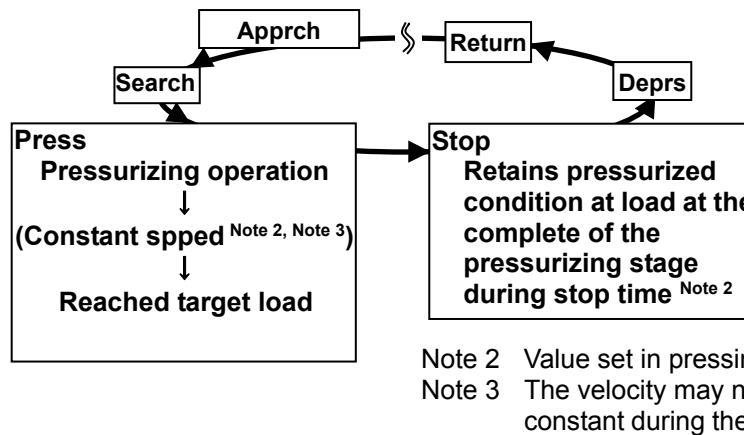

**8) Force Control Incremental Load Stop**

With the position set in pressurizing condition the target distance, movement is conducted forward (press) with the pressurizing speed kept constant up to set position (Note 1). With the load at the time that moving forward for the set distance is complete as the target load, stop is conducted with the pressing force kept constant. It should be used in the pressing operation that requires a stop at the position that the load that the set incremental load is added to the pressurizing start load is detected.

\* Program alarm gets generated when reached the pressurizing limit position.

Note 1: After transitioned to the force control, pressurizing speed would not be constant.

(The condition of transition is to be set in Parameter No. 173 Force Control Transition Threshold)

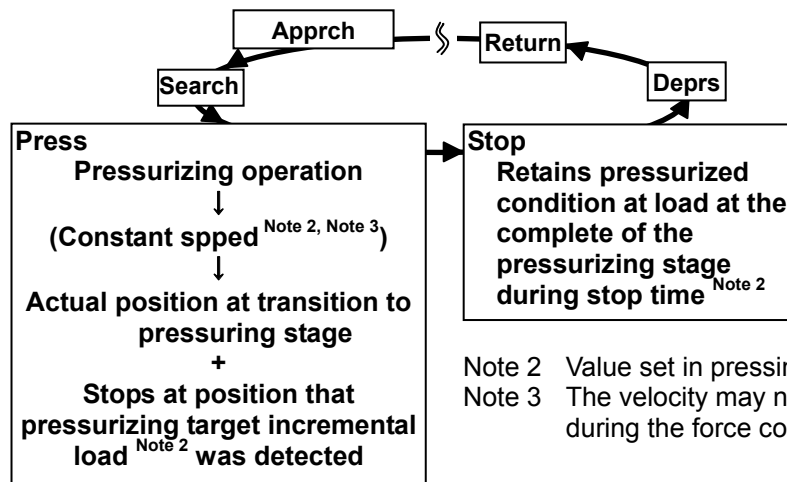

**9) Force Control Position Stop 2**

With the target load setting set in the pressurizing condition as the target, pressing operation is conducted under condition that the load reaches the target load by the pressurizing complete position. Once it reaches the setting position, stop is performed with the position retained constant.

\* Monitoring of load and position will not be conducted during stop after pressurizing is complete.

\* Program alarm will be generated if the actuator has not reached the pressurizing target load when it reached the pressurizing complete position.

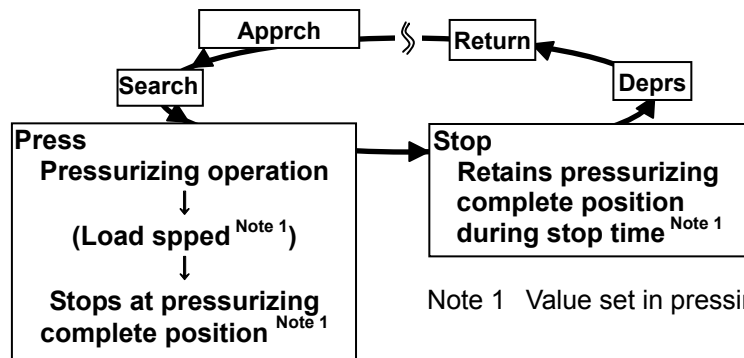

## [2] Press Program

The operation of the servo press SCON is to be conducted by setting and executing the press program.

Press program setting is to be conducted in the PC software applicable for servo press (\*).

Shown below is the flow of press program operation.

\* Refer to PC software (ME0155) provided separately for the applicable versions.

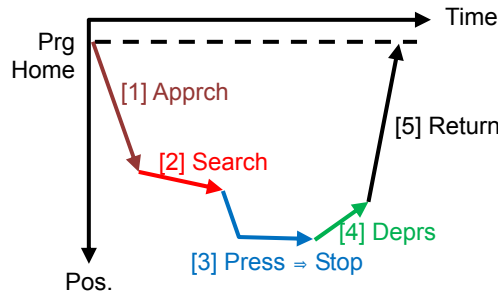

The press program consists of the 5 stage.

- 1) Approach : High speed movement before touching the work piece
- 2) Probing : Detection of touching work piece
- 3) Pressurize ⇒ Stop : Stop for indicated period after pressurizing
- 4) Decompressing : Movement away from work piece (slow-speed)
- 5) Return : Return the program home (high-speed)

## [3] Judgement

Judgment is made by the result of load and position\* at pressing work complete.

\* Setting is available also to judge only with load or position.

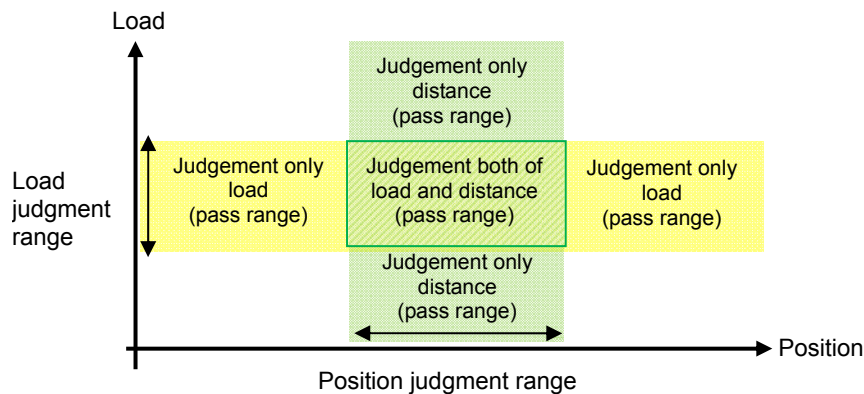

Judgment is held in every 1ms period for the duration from the moment of the pressurizing finish till the operation stop.

If a value out of the judgement range is detected even for once in the timeframe of judgment, it is judged as a failure (program alarm).

- ⚠ Caution :
- 1) Judgment will not be started until pressurizing has completed in the normal condition.
  - 2) In Force Control / Load (Incremental Load) Stop Mode, the pressurizing operation continues till the load gets in the specified range of the setting load. The program alarm will not be generated even if the load exceeds the setting load significantly at the moment of getting into the pressurizing stage. Also, judgment will not start until the load gets back in the setting load.

### 3.1.3 Basic Operation Setting

Select the pressurizing operation mode and set the five stages of the press program.

#### 3.1.3.1 Prepare a Setting

- 1) Start PC software applicable for servo press.
- 2) Select the program section in the initial window, click on the required program number and the program setting screen opens.

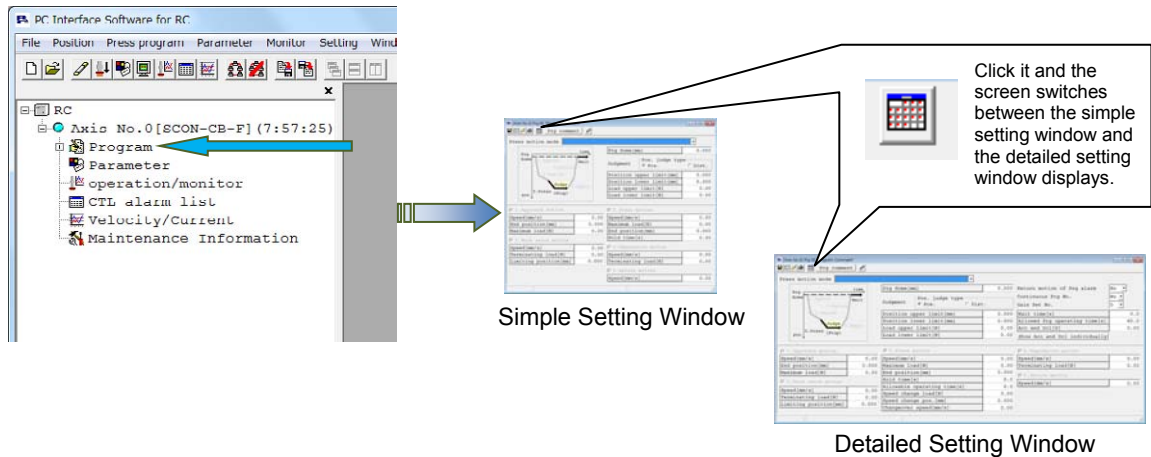

#### 3.1.3.2 Select the Press Motion Mode

Select the press motion mode on the setting window.

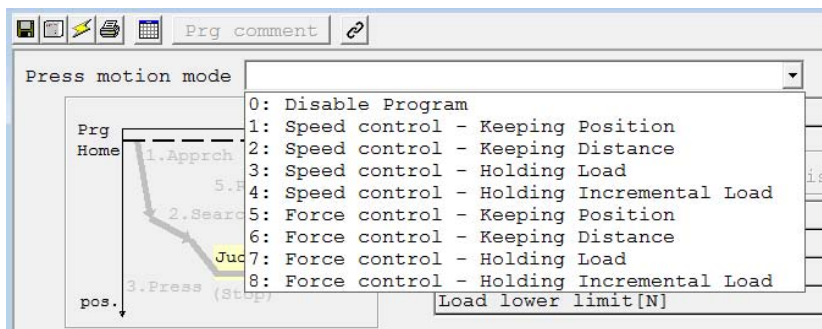

## 3.1.3.3 Setting of Press Program Each Stage

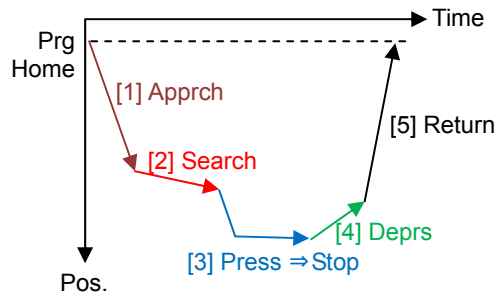

\* Even though there are 5 stages in the press program, operation can be cancelled except for the pressurizing stage which is always necessary to operate. Operation is conducted for the stages that show a check mark in the check box beside each stage No.

### [0] Setting of Program (Prg) Home

Register the press program start position.  
 Input a number in the Prg Home box.  
 Input available range  
 Prg Home [mm] = 0.000 to Effective Stroke Length

Prg Home [mm]	0.000
---------------	-------

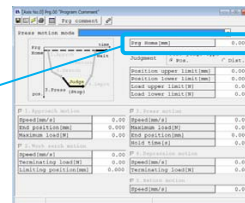

### [1] Setting of Approach Stage

It is an operation to approach before touching a work piece from the program home position.  
 Set the speed, end position, and maximum load. (It shows the input available range)

- Speed [mm/s]:  
= 1 to Actuator maximum Speed (Note 1)
- End Position [mm]:  
End Position [mm] ≤ Effective Stroke Length
- Maximum Load [N] (Load to generate Prg Alarm (Note 2) once detected):  
= 0.0 to Actuator maximum Pressing force (Note 1)  
Put a check mark if approach operation is necessary.

<input checked="" type="checkbox"/> 1. Approach motion	
Speed [mm/s]	0.00
End position [mm]	0.000
Maximum load [N]	0.00

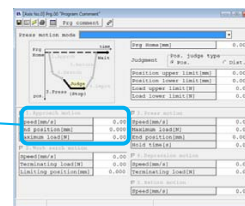

Note 1 The setting differs depending on the actuator. Refer to 9.4 Motor Capacity of Connectable Actuators for details.  
 Note 2 It returns to Prg Home Position when Prg alarm is generated. (It is available to stop at the position by setting. [Refer to 3.1.4 Detailed Setting [3]])

## [2] Setting of Work Search Stage

It is an operation to check the touch to a work piece with low speed operation. Set the speed, terminating load, and limiting position. (It shows the input available range)

- Speed [mm/s]:  
= 1 to Pressing Speed <sup>(Note 1)</sup>
- Terminating Load [N] (Load that is able to judge the touch to a work piece):  
= 0.01 to Actuator maximum Pressing force <sup>(Note 1)</sup>
- Limiting Position [mm]  
(Prg Alarm <sup>(Note2)</sup> generated if work piece not found before reaching this position):  
Approach complete position < Limiting Position [mm] ≤ Effective Stroke Length  
Prg home Home < Limiting Position [mm]  
Put a check mark if work search motion is necessary.

<input checked="" type="checkbox"/> 2. Work search motion	
Speed[mm/s]	0.00
Terminating load[N]	0.00
Limiting position[mm]	0.000

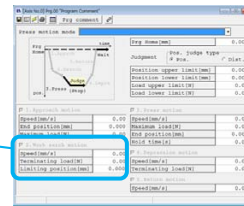

## [3] Setting of Pressurizing (Pause After Completion) Stage

Press operation is to be conducted following the selected pressurizing operation mode. Establish the settings in the sections, such as speed, stop time, etc., related to each pressurizing operation mode. (It shows the input available range)

Common Setting

- Speed [mm/s]:  
= 1 to Pressing Speed <sup>(Note 1)</sup>  
\* Speed change during pressurizing is also available. Refer to 3.1.4 Detailed Setting for detailed.
- Hold Time [s] (Stop duration till moving to depressurizing stage after pressurizing stop):  
= 0.0 to 999.9

3. Press motion	
Speed[mm/s]	0.00
Setting for each pressurizing operation mode	
Hold time[s]	0.0

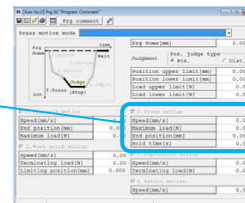

Note 1 The setting differs depending on the actuator. Refer to 9.4 Motor Capacity of Connectable Actuators for details.

Note 2 It returns to Prg Home Position when Prg alarm is generated. (It is available to stop at the position by setting. [Refer to 3.1.4 Detailed Setting [3]])



## Setting of Each Pressurizing Operation Mode

### 1) Speed Control Position Stop

- Maximum Load [N] (Load to generate Prg Alarm <sup>(Note 2)</sup> once detected):  
= 0.01 to Actuator maximum Pressing force <sup>(Note 1)</sup>
- Pressurize End Position [mm] (Position to stop pressurizing):  
Limiting Position of Probing Stage ≤ (Pressurize) End Position ≤ Effective Stroke Length

Maximum load[N]	0.00
End position[mm]	0.000

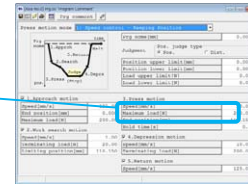

### 2) Speed Control Distance Stop

- Maximum Load [N] (Load to generate Prg Alarm <sup>(Note 2)</sup> once detected):  
= 0.01 to Actuator maximum Pressing force <sup>(Note 1)</sup>
- Pressurize End Distance [mm]  
(Distance from probing stage complete position to point to stop pressurizing):  
Complete Position of Probing Stage + (Pressurize) End Distance ≤ Effective Stroke Length

Maximum load[N]	0.00
End distance [mm]	0.000

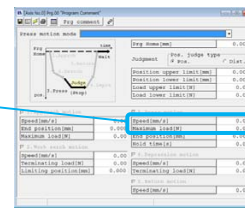

### 3) Speed Control Load Stop

- Pressurize Terminating Load [N] (Load to stop pressurizing):  
= 0.01 to Actuator maximum Pressing force <sup>(Note 1)</sup>
- Pressurize Limiting Distance [mm] (Prg Alarm <sup>(Note 2)</sup> generated once reaching this position):  
Limiting Position of Probing Stage ≤ (Pressurize) Limiting Position ≤ Effective Stroke Length

Terminating load[N]	0.00
Limiting position[mm]	0.000

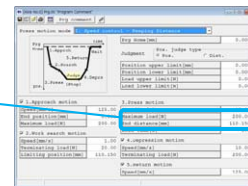

### 4) Speed Control Incremental Load Stop

- End Incremental Load [N]  
(With the load at probing stage complete as the datum, incremental load till pressurizing stop):  
= 0.01 to Actuator maximum Pressing force <sup>(Note 1)</sup>
- Pressurize Limiting Position [mm] (Prg Alarm <sup>(Note 2)</sup> generated once reaching this position):  
Limiting Position of Probing Stage < (Pressurize) Limiting Position ≤ Effective Stroke Length

End incremental load[N]	0.00
Limiting position[mm]	0.000

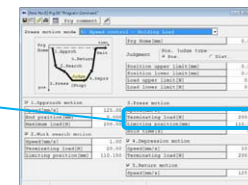

Note 1 The setting differs depending on the actuator. Refer to 9.4 Motor Capacity of Connectable Actuators for details.  
 Note 2 It returns to Prg Home Position when Prg alarm is generated. (It is available to stop at the position by setting. [Refer to 3.1.4 Detailed Setting [3]])

## 5) Force Control Position Stop

- Maximum. Load [N] (Load to generate Prg Alarm <sup>(Note 2)</sup> once detected):  
= 0.01 to Actuator maximum Pressing force <sup>(Note 1)</sup>
- Pressurize End Position [mm] (Position to stop pressurizing):  
Limiting Position of Probing Stage ≤ Pressurize End Position ≤ Effective Stroke Length

Maximum load[N]	0.00
End position[mm]	0.000

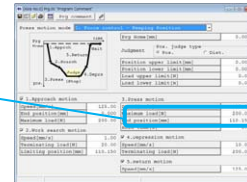

## 6) Force Control Distance Stop

- Maximum. Load (Load to generate Prg Alarm <sup>(Note 2)</sup> once detected):  
= 0.01 to Actuator maximum Pressing force <sup>(Note 1)</sup>
- Pressurize End Distance [mm]  
(Distance from probing stage complete position to point to stop pressurizing):  
End Position of Probing Stage + (Pressurize) End Distance ≤ Effective Stroke Length

Maximum load[N]	0.00
End distance[mm]	0.000

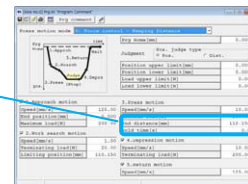

## 7) Force Control Load Stop

- Target Load [N] (Load to stop pressurizing):  
= 0.01 to Actuator maximum Pressing force <sup>(Note 1)</sup>
- Pressurize Limiting Position [mm] (Prg Alarm <sup>(Note 2)</sup> generated once reaching this position):  
Limiting Position of Probing Stage + Pressurize Limiting Position ≤ Effective Stroke Length

Target load[N]	0.00
Limiting position[mm]	0.000

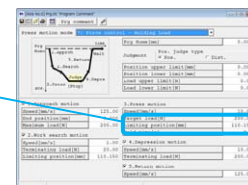

## 8) Force Control Incremental Stop

- Target Incremental Load [N]  
(With the load at probing stage complete as the datum, incremental load till pressurizing stop):  
= 0.01 to Actuator maximum Pressing force <sup>(Note 1)</sup>
- Pressurize Limiting Position [mm] (Prg Alarm <sup>(Note 2)</sup> generated once reaching this position):  
Limiting Position of Probing Stage < Pressurize Limiting Position ≤ Effective Stroke Length

Target incremental load[N]	0.00
Limiting position[mm]	0.000

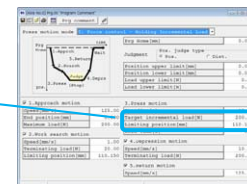

Note 1 The setting differs depending on the actuator. Refer to 9.4 Motor Capacity of Connectable Actuators for details.

Note 2 It returns to Prg Home Position when Prg alarm is generated. (It is available to stop at the position by setting. [Refer to 3.1.4 Detailed Setting [3]])

### 9) Force Control Position Stop 2

- Target Load [N] (Target load at pressurizing operation):  
= 0.01 to Max. Pressing Force
- Pressurizing Complete Position [mm] (position to stop pressurizing):  
Searching Stage Limit Position ≤ Pressurizing Complete Position ≤ Effective Stroke Length

Target load[N]	0.00
End position[mm]	0.000

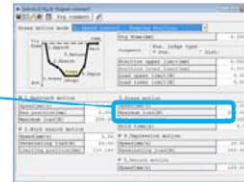

Note 1 The setting differs depending on the actuator. Refer to 9.4 Motor Capacity of Connectable Actuators for details.  
 Note 2 It returns to Prg Home Position when Prg alarm is generated. (It is available to stop at the position by setting. [Refer to 3.1.4 Detailed Setting [3]])

### [4] Setting for Decompressing stage

It is an operation to move away from a work piece in low speed.  
 Set the speed, depression terminating load. (It shows the input available range)

- Speed [mm/s]:  
= 0.01 to Pressing Speed (Note 1)
- Depression Terminating Load [N]  
(judged as depressurizing complete once the load gets below this setting):  
= 0.01 to Actuator maximum. Pressing force (Note 1)  
Put a check mark if Depression motion is necessary.

<input checked="" type="checkbox"/> 4. Depression motion	
Speed[mm/s]	0.00
Terminating load[N]	0.00

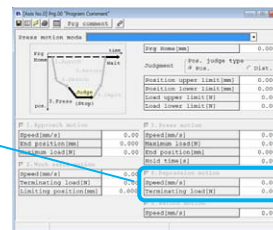

### [5] Setting for Probing Stage

It is an operation to move away from a work piece in high speed and return to the program home position.  
 Set the speed. (It shows the input available range)

- Speed [mm/s]:  
= 1 to Actuator maximum Speed (Note 1)  
Put a check mark if Return motion is necessary.

<input checked="" type="checkbox"/> 5. Return motion	
Speed [mm/s]	0.00

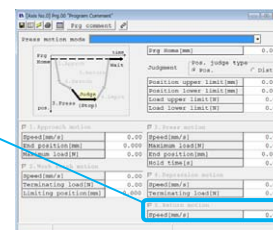

## [6] Judgement

Judgment can be conducted with the position (distance) and load while in stop time at the pressurizing stage complete.

Setting is available also to judge only with load or position.

Set the upper and lower limits for the position and load. (It shows the input available range)

Caution 1) Upper Limit = Judgment will not be executed if set to lower limit.

2) Upper Limit < Prg Alarm <sup>(Note 2)</sup> will be generated if set to Upper Limit < Lower Limit.

- Position (distance) Upper Limit [mm]:  
= 0.000 to Effective Stroke Length
- Position (distance) Lower limit [mm]:  
= 0.000 to Effective Stroke Length
- Load Upper Limit [N]:  
= 0.01 to 100% of actuator maximum pressing force <sup>(Note 1)</sup>
- Load Lower Limit [N]:  
= 0.01 to Actuator maximum pressing force <sup>(Note 1)</sup>

**Judgment with Position**

Judgment		Pos. judge type
		<input checked="" type="radio"/> Pos. <input type="radio"/> Dist.
Position upper limit [mm]	0.000	
Position lower limit [mm]	0.000	
Load upper limit [N]	0.00	
Load lower limit [N]	0.00	

**Judgment with Distance**

Judgment		Pos. judge type
		<input type="radio"/> Pos. <input checked="" type="radio"/> Dist.
Distance upper limit [mm]	0.000	
Distance lower limit [mm]	0.000	
Load upper limit [N]	0.00	
Load lower limit [N]	0.00	

**Note 1** The setting differs depending on the actuator. Refer to 9.4 Motor Capacity of Connectable Actuators for details.

**Note 2** It returns to Prg Home Position when Prg alarm is generated. (It is available to stop at the position by setting. [Refer to 3.1.4 Detailed Setting [3]])

This is the end of the press program basic setting.  
Transfer → Write in the set content to the controller.

**Transfer Button**  
Click it to transfer the setting to the controller.

To establish settings in detail such as to have a chained operation of several programs or operation at Prg Alarm generation, refer to the detailed setting in the following page.

## 3.1.4 Detailed Settings (Optional Settings)

Set the following detailed items if necessary.

- [1] Gain set
- [2] Continuous Prg No.
- [3] Return Motion of Prg Alarm
- [4] Acc and Dcl
- [5] Show Acc and Dcl Individually
- [6] Wait Time
- [7] Allowed Prg Operating Time
- [8] Detailed Settings for Pressurizing Stage (Allowable Operation Time, Speed Switchover)

Settings are to be established in the detailed setting window.

Click on the indicated button in the simple setting window, and the screen switches to the detailed setting window.

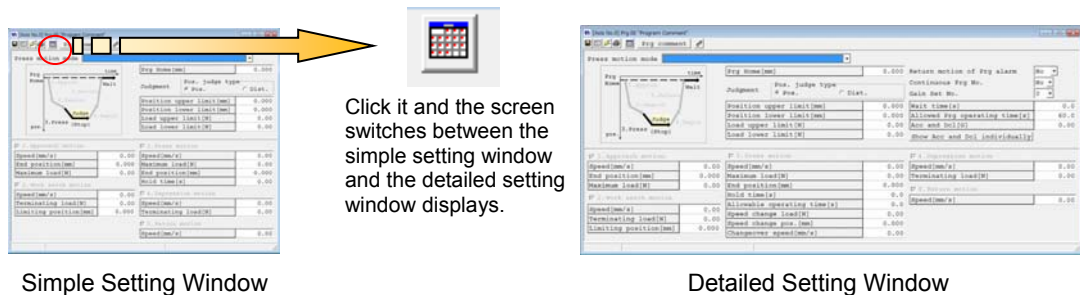

### [1] Gain set

The four types of servomotor gain settings registered in advance can be switched over for each press program. [Servo adjustment refer to section 7.3]

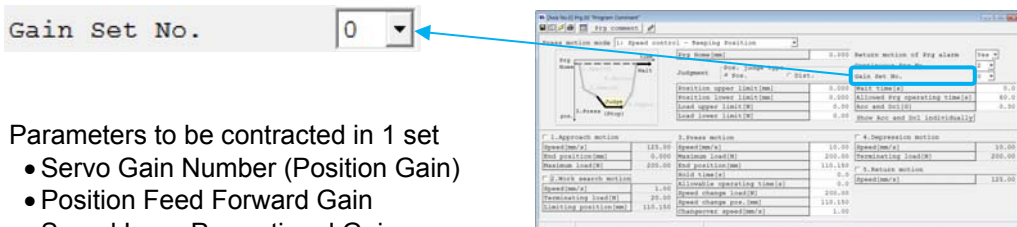

- Parameters to be contracted in 1 set
- Servo Gain Number (Position Gain)
  - Position Feed Forward Gain
  - Speed Loop Proportional Gain
  - Speed Loop Integral Gain
  - Torque Filter Time Constant
  - Current Control Band Number
  - Force Gain

Set the indicated gain set number in the gain set box.

Setting	Parameter Set Select	Parameter No.
0	Gain set 0	7, 71, 31 to 33, 54, 94
1	Gain set 1	120 to 125, 174
2	Gain set 2	126 to 131, 175
3	Gain set 3	132 to 137, 176

[2] Continuous Prg No.

If several press programs are required to be operated in a row, indicate the program number that is desired to be executed. Programs can be chained infinitely. Also, the same program No. can be set.

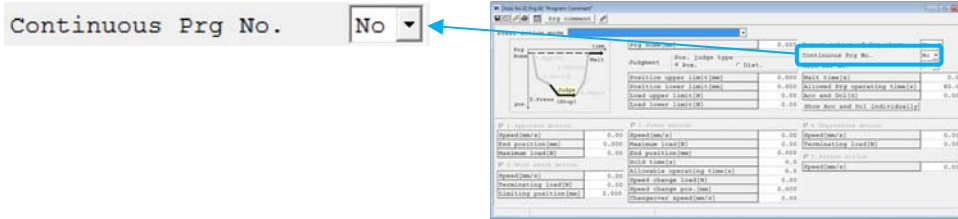

e.g.) Using Press Program 1 only up to the pressurizing stage, and have Press Program 2 in charge for the pressurizing stage and returning stage to have a double pressing operation. (Set 2 to the chain Prg number of Press Program 1)

- Setting for Press Program 1:

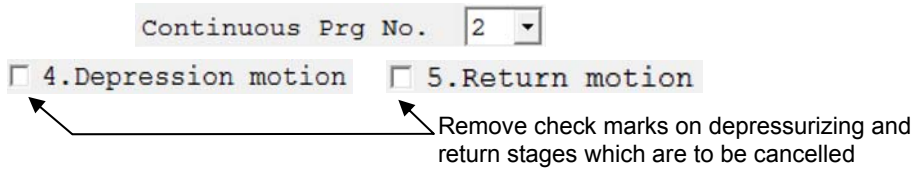

- Setting for Press Program 2:

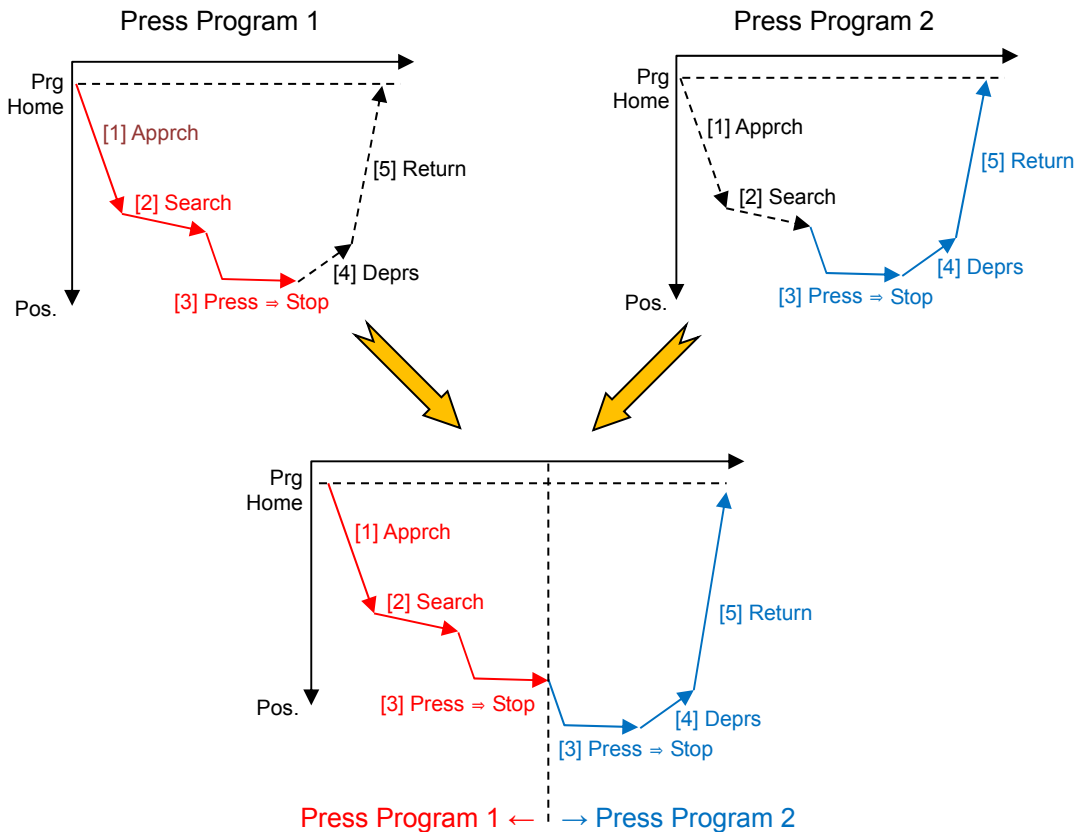
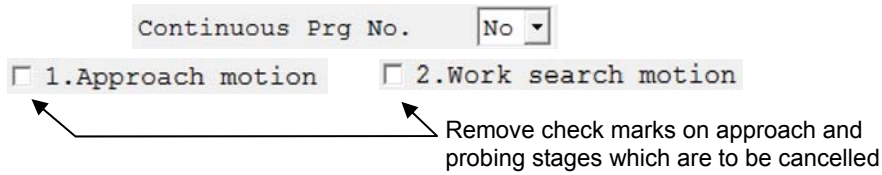

[3] Return Motion of Prg Alarm

Select whether to return to Prg Home Position and turn the servo OFF or to stop at the point without returning when Prg Alarm is generated.

Return motion of Prg alarm

- Yes : To return
- No : Not to return

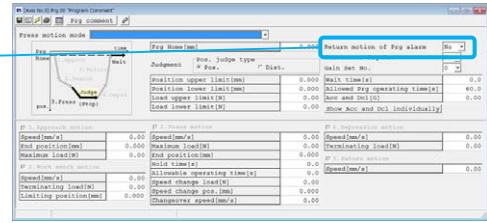

Note 1: When an alarm other than Prg Alarm is generated, operation to return to Prg Home Position would not be made. It stops at the point.

Note 2: When returning to Prg Home Position, Parameter No. 8 Speed Initial Value is used for speed and Parameter No. 9 Acceleration/Deceleration Initial Value for acceleration and deceleration.

[4] Acc and Dcl

Establish the setting for acceleration when operating the actuator in the press program. Check [5] Show Acc and Dcl Individually in the next section when setting the acceleration and deceleration individually for each stage. (It shows the input available range)

- Acc and Dcl [G]: = 0.01 to Actuator maximum Acc and Dcl (Note 1)

Acc and Dcl[G]

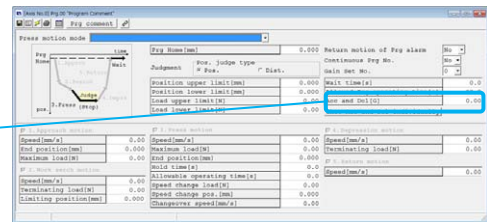

(Reference) In here, explains acceleration. The concept is the same for deceleration.  
 1G = 9800mm/s<sup>2</sup>: Acceleration to accelerate up to 9800mm/s in 1 second  
 0.3G: Acceleration to accelerate up to 9800mm/s × 0.3 = 2940mm/s in 1 second

[5] Show Acc and Dcl Individually

Establish the setting for acceleration of the actuator for each stage in a press program.

Show Acc and Dcl individually

Press Show Acc and Dcl Individual Button, and the acceleration and deceleration items get displayed in the setting items for each stage and setting adjustment becomes available. (It shows the input available range)

- Acc and Dcl [G]: = 0.01 to Actuator maximum Acc and Dcl (Note 1)

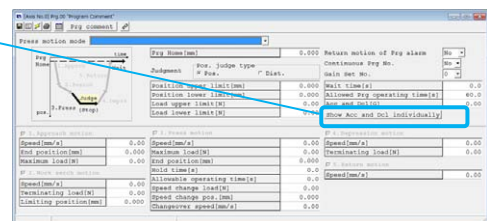

Note 1 The setting differs depending on the actuator. Refer to 9.4 Motor Capacity of Connectable Actuators for details.

## [6] Wait Time

Establish the setting for the wait time after a press program is completed in normal condition till the next program start command or chained Prg start. (It shows the input available range)

- Wait Time [s]:

= 0 to 999.9

Wait time[s]      0.0

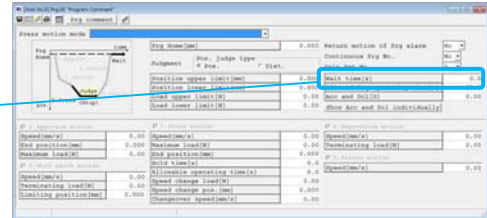

## [7] Allowed Prg Operating Time

Establish the setting for the allowable operation time for one program. When chained program is set, monitoring is conducted in the time set for each program. Prg alarm (Note 1) will be generated if a program does not finish in this time (wait time excluded). Also, judgment will not take place if set to 0. (It shows the input available range)

- Allowed Prg Operating Time [s]:

= 0 to 999.9

Allowed Prg operating time[s]      60.0

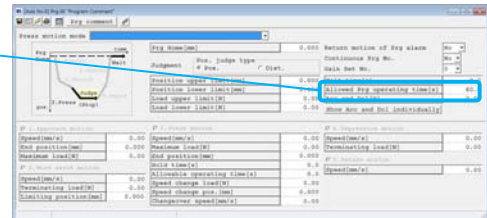

Note 1 It returns to Prg Home Position when Prg alarm is generated. (It is available to stop at the position by setting. [Refer to Detailed Setting (this chapter) [3]])



## [8] Detailed Settings for Pressurizing Stage (Allowable Operating Time, Speed Changeover)

### 1) Allowable Operating Time

Establish the setting for the allowable time of pressurize operation. Prg Alarm <sup>(Note 2)</sup> will be generated if exceeding the set time.

Also, judgment will not be executed if set to 0. (It shows the input available range)

- Allowable Operating Time [s]:  
= 0.0 to 999.9

Allowable operating time[s] 0.0

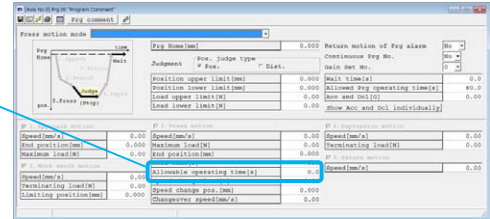

### 2) Speed Changeover

When reached the set position (distance)\* or set (incremental) load\* during pressurizing, the speed switches to that set as the switching speed. However, the speed switchover would not be conducted and moves to stop operation if the pressurizing complete condition is satisfied before. (It shows the input available range)

\* It differs depending on the selected pressurizing operation mode.

- Speed Change Pos. [mm]:  
= 0.001 to Effective Stroke Length

Speed change pos. [mm] 0.000

- Speed Change Load [N]:  
= 0.01 to maximum. Pressing Force <sup>(Note 1)</sup>

Speed change load[N] 0.00

- Changeover Speed [mm/s]:  
= 0.01 to Pressing Speed <sup>(Note 1)</sup>

Changeover speed[mm/s] 1.00

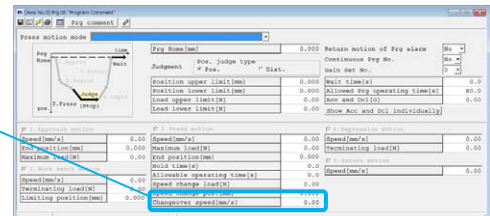
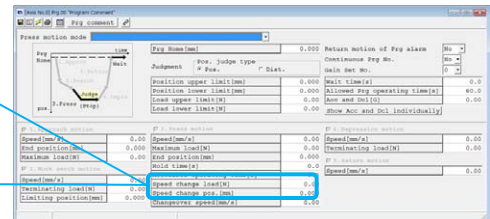

Note 1 The setting differs depending on the actuator. Refer to 9.4 Motor Capacity of Connectable Actuators for details.

Note 2 It returns to Prg Home Position when Prg alarm is generated. (It is available to stop at the position by setting. [Refer to Detailed Setting (this chapter) [3]])

### 3.2 Trial Run

Have a trial operation of the program set in the PC software.

**Caution:** (1) Do not attempt to establish the setting that exceeds the rated acceleration/deceleration speed which is stated in the catalog or an instruction manual of an actuator. Setting above the rated acceleration/deceleration may shorten the actuator life remarkably.  
 (2) In case there is impact or vibration on the actuator or work piece, decrease the acceleration and deceleration. Keeping using in such condition will shorten the actuator life remarkably.

#### 3.2.1 Manual Operation (Jog etc)

Open the operation window by selecting Operation/Monitoring. 1) Select the trial operation tag, 2) turn the servo ON, 3) have a home-return operation, and then 4) press Jog/Inching Button to have the actuator drive back and forth.

Input a number in 5) Position and 6) Speed and press  to have the direct indication movement to the input position.

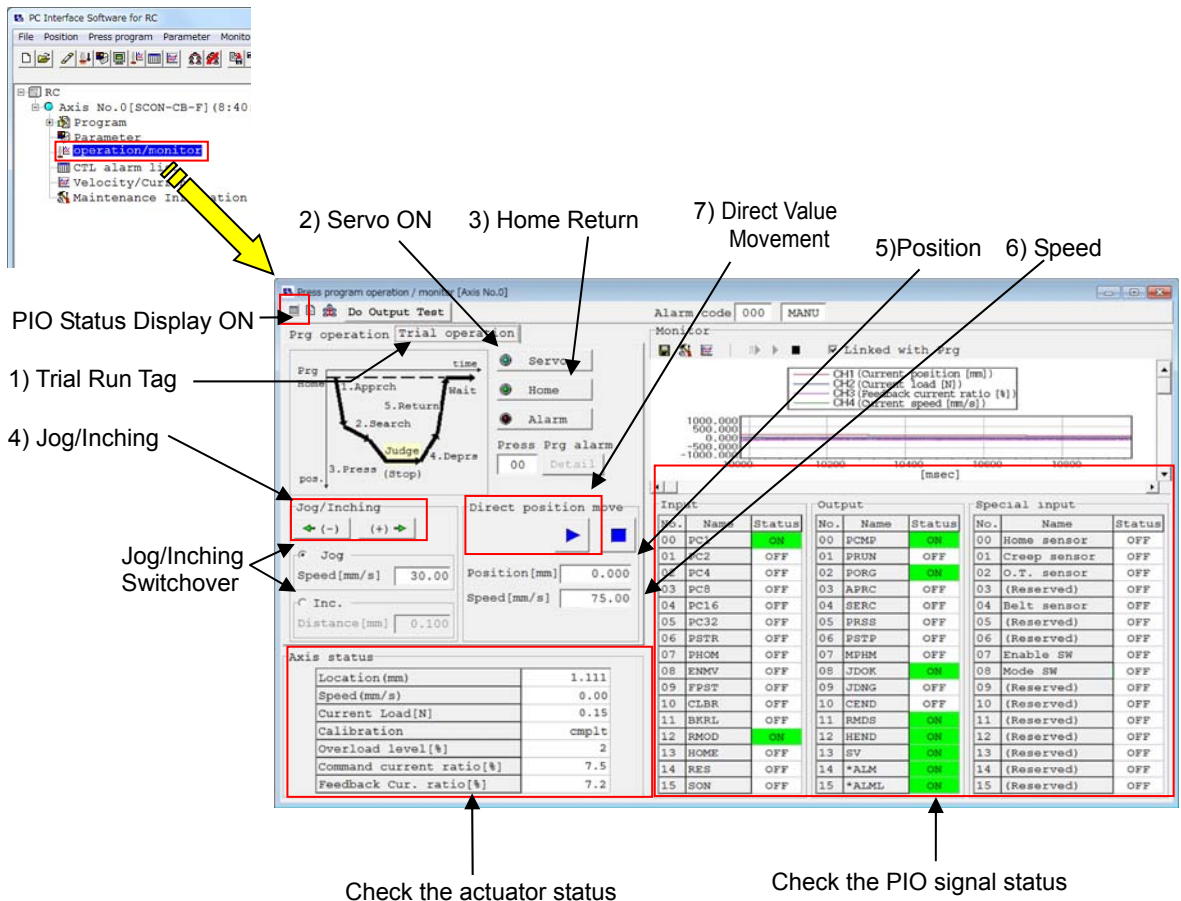

The screenshot shows the 'PC Interface Software for RC' with the 'Operation/monitor' window open. The window is annotated with numbered callouts:

- 1) Trial Run Tag:** Points to the 'Do Output Test' button.
- 2) Servo ON:** Points to the 'Servo' button.
- 3) Home Return:** Points to the 'Home' button.
- 4) Jog/Inching:** Points to the 'Jog/Inching' button.
- 5) Position:** Points to the 'Position[mm]' input field.
- 6) Speed:** Points to the 'Speed[mm/s]' input field.
- 7) Direct Value Movement:** Points to the 'Direct position move' button.

Other annotations include:

- PIO Status Display ON:** Points to a checkbox in the top left.
- Jog/Inching Switchover:** Points to the 'Jog' and 'Inc.' buttons.
- Check the actuator status:** Points to the 'Axis status' table.
- Check the PIO signal status:** Points to the 'Input', 'Output', and 'Special input' tables.

**Axis status table:**

Location[mm]	1.111
Speed[mm/s]	0.00
Current Load[N]	0.15
Calibration	cmplt
Overload level[%]	2
Command current ratio[%]	7.5
Feedback Cur. ratio[%]	7.2

**Input, Output, and Special input tables:**

No.	Name	Status	No.	Name	Status	No.	Name	Status
00	PC1	ON	00	PCMP	ON	00	Home sensor	OFF
01	PC2	OFF	01	PRUN	OFF	01	Creep sensor	OFF
02	PC4	OFF	02	PORG	ON	02	O.T. sensor	OFF
03	PC8	OFF	03	APRC	OFF	03	(Reserved)	OFF
04	PC16	OFF	04	SERC	OFF	04	Belt sensor	OFF
05	PC32	OFF	05	PRSS	OFF	05	(Reserved)	OFF
06	PSTR	OFF	06	PSTP	OFF	06	(Reserved)	OFF
07	PHCM	OFF	07	MPHM	OFF	07	Enable SW	OFF
08	ENMV	OFF	08	JDOK	ON	08	Mode SW	OFF
09	FPST	OFF	09	JNGK	OFF	09	(Reserved)	OFF
10	CLBR	OFF	10	CEND	OFF	10	(Reserved)	OFF
11	BKRL	OFF	11	RMDS	ON	11	(Reserved)	OFF
12	RMOD	ON	12	HEND	ON	12	(Reserved)	OFF
13	HOME	OFF	13	EV	ON	13	(Reserved)	OFF
14	RES	OFF	14	*ALM	ON	14	(Reserved)	OFF
15	SON	OFF	15	*ALML	ON	15	(Reserved)	OFF

### 3.2.2 Press Program Operation

#### [1] Preparation for Press Program Execution

Open the operation window by selecting Operation/Monitoring. The operation window differs from [3.2.1 Manual Operation] only in the operation part in the left of the window.

- 1) Select the Prg operation tag, 2) turn the servo ON and 3) have a home-return operation.
- 4) Indicate the start press program number, 5) press Prg Home Position and the actuator moves to the press program home position. 6) If finishing the program in 6) probing operation, press Probing Stop.

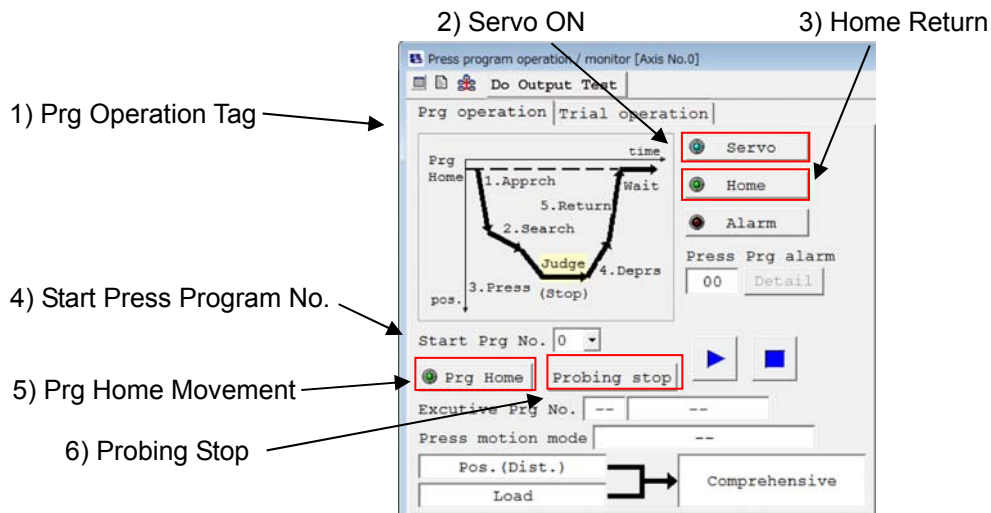

#### [2] Execute Press Program

- 1) Press to execute a press program.
- 2) Once the press program is finished in normal condition, results will be displayed in judgment, position (distance) judgment and load judgment.
- 3) In case an alarm is generated on the way, the alarm code will be displayed in Prg Alarm. Refer to Chapter 8 Troubleshooting to get rid of the cause of the alarm. To cancel the alarm, press alarm button.

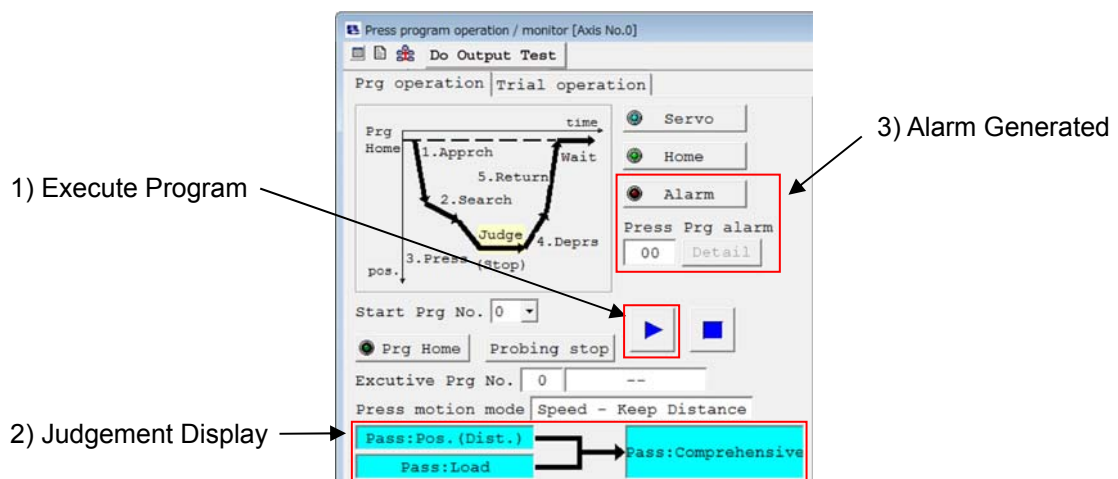

- Shown below is an example of the judgment window for the load judgment alarm. Alarm Code 4A gets generated when the load at press operation finish is not in the range of upper and lower limits of the judgment load.

The screenshot displays the 'Press program operation / monitor [Axis No.0]' window. It features a graph of 'time' vs 'pos.' with steps: 1.Approach, 2.Search, 3.Press (Stop), 4.Deprs, 5.Return, and Wait. Below the graph are controls for 'Start Prg No.', 'Prg Home', 'Probing stop', 'Excutive Prg No.', and 'Press motion mode'. A status bar at the bottom shows 'Pass:Pos. (Dist.)' and 'Fail:Load' leading to 'Fail:Comprehensive'. An 'Alarm' button is highlighted, and a 'Program alarm detail' window is open, displaying '4A : Fail: Load judgment [Axis No.0][Program No.0]' with an 'OK' button.

Turn on the Alarm Lamp  
Press Detail and content of an alarm is displayed.

Alarm Code

All Judgement NG

## 3.3 Operation with PIO

### 3.3.1 I/O Signal Controls

The input signal of this controller has the input time constant of 6ms considering the prevention of wrong operation by chattering and noise. Therefore, input each input signal for 6ms or more continuously. The signal cannot be identified if it is less than 6ms.

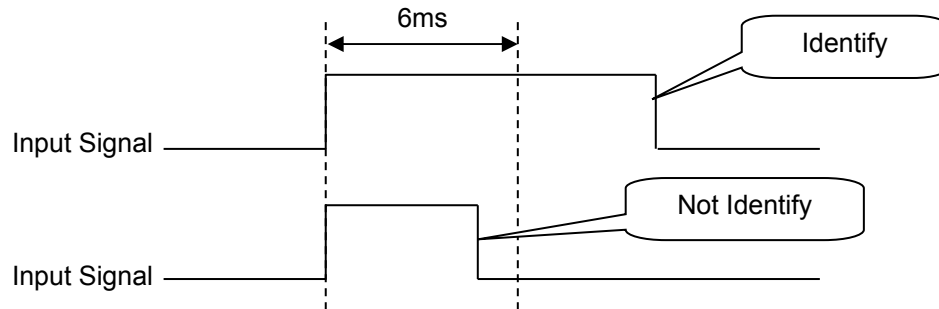

### 3.3.2 Operation Ready and Auxiliary Signals

[1] Operation Mode Switch (RMOD, RMDS)

PIO Signal	Input	RMOD
	Output	RMDS

Two operation modes are provided so that the operation by PIO signals does not overlap with the operation by a teaching tool such as PC software through SIO (serial) communication. The mode change is normally done by the RMOD signal or operation mode setting switch ON the front panel of the controller.

AUTO ..... Operation by PIO signals is valid.  
 MANU ..... Operation through teaching tool is valid.

The controller can be entered into the [MANU] mode by setting RMOD signal to ON. Because the RMOD signal is set to ON with the [MANU] mode selected by using the signal, make the operation sequence interlocked. The table below lists the switches ON the front panel, the modes selected by the RMOD signal and the corresponding output states of the RMDS signal.

○ : Selected or set to ON, × : Unselected or set to OFF

Condition		Status							
Teaching tool such as PC software	PIO Operation Invalid (Note 1)	○	○	○	○	×	×	×	×
	PIO Operation Allowed (Note 1)	×	×	×	×	○	○	○	○
Switches ON front panel	AUTO	○	○	×	×	○	○	×	×
	MANU	×	×	○	○	×	×	○	○
PIO Input	RMOD	×	○	×	○	×	○	×	○
PIO Output	RMDS	×	○	○	○	×	○	○	○
PIO valid: ◎, PIO invalid: ●		◎	●	●	●	◎	◎	◎	◎

Operation by normal PIO

Note 1 [PIO Operation Allowed] or [PIO Operation Invalid] is the function to select a restriction while the teaching tool such as PC software is connected.

**⚠ Caution:** (1) Note that selecting [PIO Operation Allowed] by using the teaching tool such as PC software makes all PIO signals valid to enable operation however the states of the switches and RMOD signal input may be. In this status, the actuator may be started depending on the signals from PLC.

(2) If the teaching tool such as PC software is disconnected from the controller, [PIO Operation Allowed] or [PIO Operation Invalid] holds the state selected before. After teaching operation or debugging is terminated, select [PIO Operation Allowed] and disconnect the teaching tool such as PC software from the controller.

### [2] Servo ON (SON, SV)

PIO Signal	Input	SON
	Output	SV

- 1) Servo ON signal SON is the input signal making the servo motor of the actuator operable.
- 2) If the servo ON is performed to enable operation, the SV output signal is turned ON.
- 3) With the power being supplied, then controller cannot be operated while the SV signal remains OFF. If the SON signal is turned OFF under operation of the actuator, the actuator is decelerated and stopped with the forced stop torque. After the stop, the servo OFF occurs to enter the motor into the free running state.

The brake (option) is of release-in-excitation type. Therefore, making the excitation on will release the brake (release) while making it OFF will lock the brake (lock).

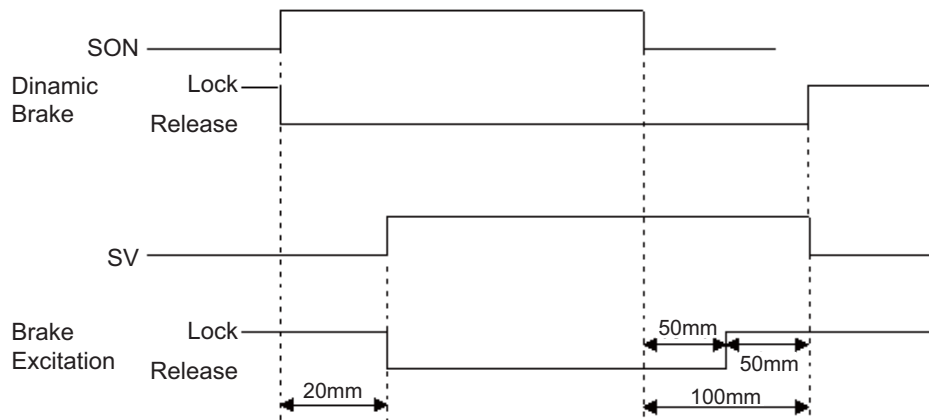

[3] Home Return (HOME, HEND)

PIO Signal	Input	HOME
	Output	HEND

The HOME signal is intended for automatic home return. The HOME signal is caught at the rising edge (ON edge) to start the home return. At completion of the home return, home return completion signal HEND is turned ON. The home-return complete signal HEND is kept on unless the memory of origin point is lost for a reason. Executing a press program without conducting the home-return operation will cause a program alarm.

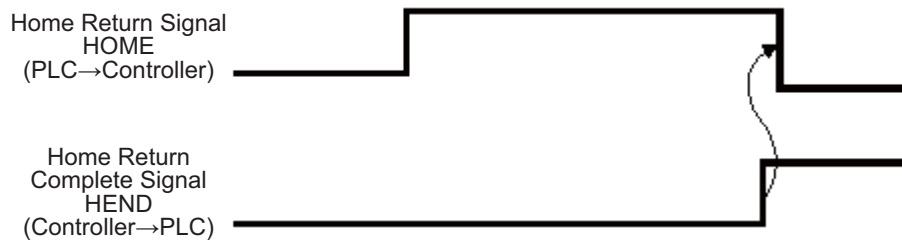

[Operation of Rod Type Actuator]

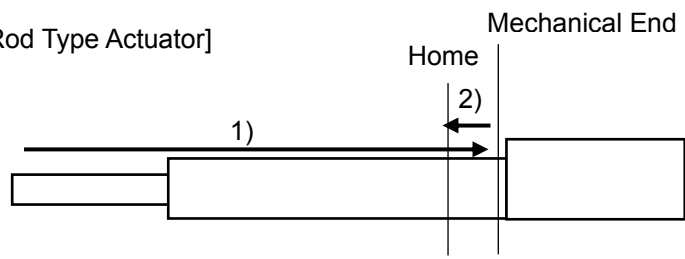

- 1) With the HOME signal being ON, the actuator moves toward the mechanical end at the home return speed.  
The moving speed is 20mm/s for most actuators but less than 20mm/s for some actuators. Refer to the instruction manual of each actuator.
- 2) The actuator is turned at the mechanical end and stopped at the home position. The moving distance <sup>(Note 1)</sup> is the value set by Parameter No.22 "Home return offset level".  
Note 1 It moves for the offset amount after the encoder Z-phase is detected.

[4] Alarm and Alarm Reset (\*ALM, RES)

PIO Signal	Input	RES
	Output	*ALM

- 1) Alarm signal \*ALM is set to ON in the normal status but turned OFF at the occurrence of an alarm at a level equal to or higher than the operation release level.
  - 2) Turning reset signal RES ON under occurrence of an alarm at the operation release level allows the alarm to be released. The action is taken at the rising edge (ON edge).
  - 3) The alarm reset should be done after the cause of the alarm is confirmed and removed. If alarm reset and restart are repeated many times without removal of the cause, a severe failure such as motor burnout may occur.
- (Note) Check the Alarm List for details of alarms.

[5] Light Failure Alarm (\*ALML)

PIO Signal	Output	*ALML
------------	--------	-------

The light malfunction alarm output (\*ALML Signal) turns off if a message level alarm gets generated due to such reasons as number of movement times target exceeding or error in the calendar feature.

This signal will be ON as long as the message level alarm is not issued.

[Refer to 8.4 Alarm Level of Alarm List for details.]

[6] Breake Release (BKRL)

PIO Signal	Input	BKRL
------------	-------	------

The brake can be released while BKRL signal is set to ON. For an actuator equipped with a brake, the brake is controlled automatically by ON/OFF of servo, but is necessary, in some cases such as for tuning which requires to move the rod manually by hand, to release the brake. This operation can be done by break release signal BKRL as well as the brake release switch ON the front panel of the controller.

 **Warning:** (1) Take sufficient care to release the brake. Inappropriate drop of the slider or rod may cause injury or malfunction of actuator body, work piece or system.  
 (2) After the brake is released, always make the brake applied again. Any operation with the brake remaining released is extremely dangerous. The slider or rod may drop to cause people to be injured and/or the actuator, the work and/or the machine to be damaged.



## [7] Load Cell Calibration (CLBR, CEND)

PIO Signal	Input	CLBR
	Output	CEND

A loadcell with no load is set to 0 [N] at shipment.

Do not fail to conduct a calibration when the condition that a pressing tool such as a pusher is attached is set to the origin (0 [N]).

Just before highly precise pressing, provide readjustment and inspection depending on the condition. (Set Parameter No. 117 to 1, and calibration is automatically conducted at the controller startup. Refer to explanations for parameter for details.)

- 1) Stop the operation. (Calibration cannot be performed while any axis is operating, pushing a work part or pause. If calibration signal CLBR is set to ON, alarm 0E1 Loadcell Calibration Error occurs).
- 2) Turn ON the load cell calibration signal (CLBR).
- 3) Once the calibration is complete, the calibration complete signal (CEND) turns ON. Thereafter, turn OFF the CLBR signal.  
If the calibration was not successful, a 0E1 Loadcell Calibration Error alarm generates. Try the calibration again.

**Caution:** Normal operation commands are not accepted while the CLBR signal is ON.

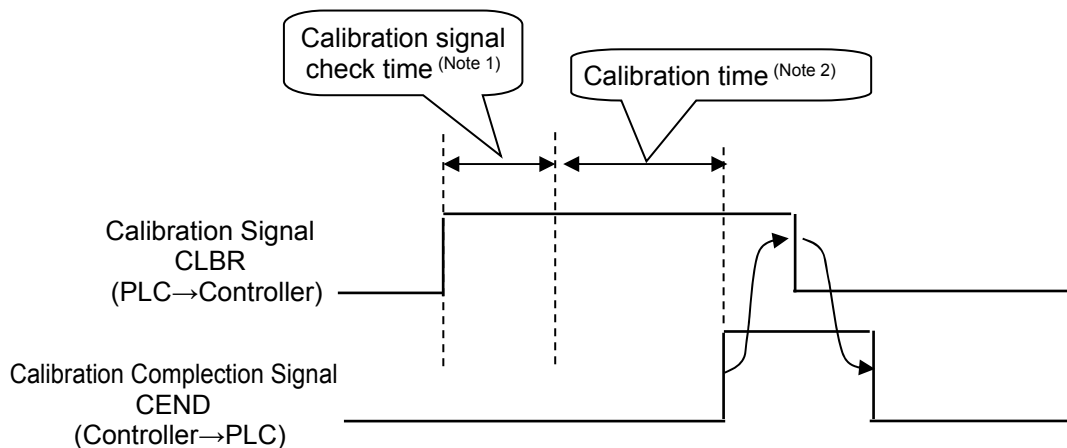

**Note 1** The time zone indicates the calibration signal check time (20ms). If CLBR is turned OFF within the period, the calibration signal is ignored to cancel the calibration.

**Note 2** The calibration time depends on Parameter No.119 "Loadcell Calibration Time" (factory setting: 10ms). However, if it is set to the automatic calibration at startup, the time should be fixed to 10ms no matter what the parameter setting is.

If CLBR is turned OFF during the period before CEND is turned ON, alarm 0E1 "Loadcell Calibration Error" occurs.

**[Reference]** Loadcell is a delicate measurement tool. To maintain its accuracy, it is suggested to have a calibration at regular intervals (conducted by the supplier). Please contact us for the details related to the calibration such as the calibration frequency.

**Caution:** The value to start calibration becomes (0 [N]) in the calibration. Therefore, make sure not to apply any load other than the weight of the tool attached on the loadcell at the calibration.

## 3.3.3 Operation

As a preparation for operation, after conducting to turn the servo ON, home-return operation and loadcell calibration, movement is made to Prg Home Position.

Indicate the press program number to operate next, and by inputting the press program start signal, the press program starts. To finish the program compulsorily, input the compulsory complete signal.

### 3.3.3.1 Operation Signal

#### [1] Program Operation

PIO Signal	Input	PC1 to PC32	Press program number
		PSTR	Press program start
		PHOM	Press program home movement
		ENMV	Accept axis operation
		FPST	Press program compulsory stop
	Output	PCMP	Press program finished in normal condition
		PRUN	Press program executed
		PORG	Press program home position
		APRC	While in approaching operation
		SERC	While in probing operation
		PRSS/PSTP	While in pressurizing operation/ While in pressurizing stop
		MPHM	In operation to press program home position
		JDOK/JDNG	Judgement OK / Judgement NG

#### [2] Press program number, Press program start (PC1 to PC32, PSTR)

PIO Signal	Input	PC1 to PC32
		PSTR

The press program number is shown with binary numbers in six digits from PC1 to PC32.

Press Program Number	Binary Description	PC32	PC16	PC8	PC4	PC2	PC1
0	000000	0	0	0	0	0	0
1	000001	0	0	0	0	0	1
			:				
15	001111	0	0	1	1	1	1
			:				
63	111111	1	1	1	1	1	1

It is to be indicated when executing the press program startup command. After indicating the press program number, turn on the press program start signal (PSTR), and then the indicated press program gets executed.

If PSTR Signal is turned ON during the press program execution or actuator operation, a program alarm occurs.

[3] Press Program Executed, Press Program Finished in Normal Condition (PRUN, PCMP)

PIO Signal	Output	PRUN
		PCMP

After the returning stage from the program start, PRUN signal turns ON to show the press program is executed until the standby time (setting established in detail settings) has passed. PCMP signal shows the press program has finished in normal condition. It turns on at the time that the returning stage is finished (standby time setting does not affect), and is kept ON until next press program execution, movement command or servo-OFF. PCMP signal would not turn ON at the press program home position movement complete.

[4] Press Program Home Movement, Press Program Home during Movement, Home Position (PHOM, MPHM, PORG)

PIO Signal	Input	PC1 to PC32
		PHOM
	Output	MPHM
		PORG

If the press program home position movement command signal (PHOM) is turned ON after displaying the press program number with binary numbers in six digits from PC1 to PC32, movement will be made to the program home position of the indicated press program. For the speed at the movement to the program home position, Parameter No. 8 Speed Initial Value is used. For acceleration and deceleration, Parameter No. 9 Acceleration/Deceleration Initial Value is used.

MPHM signal (\*) turns on during the program home position movement.

It stops after reaching the program home position, and PORG signal turns ON during stop. The program alarm occurs if turning PHOM signal ON while executing the press program.

\* MPH M signal turns ON also during depressurizing operation and returning operation.

[5] Accept Axis Operation (ENMV)

PIO Signal	Input	ENMV
------------	-------	------

The actuator is accepted to operate while this signal is ON.

The operation of the actuator and the press program stop when this signal is OFF.

This signal cannot be used for pause of the press program. (The press program would not resume even if stopping the press program with this signal and turn it ON again.)

[6] Press Program Compulsory Stop (FPST)

PIO Signal	Input	FPST
------------	-------	------

Turn this signal ON during the press program execution, and the press program in execution stops.

When this signal is turned ON, operation to return or not to return to the program home position is executed following the setting in Parameter No. 179 Returning Operation at Press Program Compulsory Stop. For the speed to return, Parameter No. 8 Speed Initial Value is used. For acceleration and deceleration, Parameter No. 9 Acceleration/Deceleration Initial Value is used.

This signal cannot be accepted during the press program home position movement.

[7] While in Approaching Operation (APRC)

PIO Signal	Output	APRC
------------	--------	------

While in approaching operation, this signal turns ON.

[8] While in Probing Operation (SERC)

PIO Signal	Output	SERC
------------	--------	------

While in probing operation, this signal turns ON.

[9] While in Pressurizing Operation (PRSS)

PIO Signal	Output	PRSS
------------	--------	------

While in pressurizing operation, this signal turns ON.

[10] While in Pressurizing Stop (PSTP)

PIO Signal	Output	PSTP
------------	--------	------

This signal turns on during stop after pressurizing complete.

[11] Judgement OK/ Judgement NG (APRC)

PIO Signal	Output	JDOK
		JDNG

Normal (JDOK) or error (JDNG) turns on following the result of pressing operation.

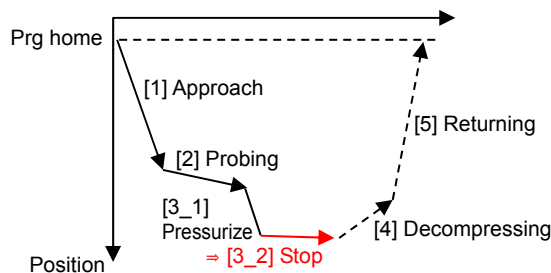

Judgement \* is conducted after pressurizing finish.

(Judgement is available even if 0 is set to stop time.)

\* Judgement is to be conducted following the setting (basic setting) of the judgement stage.

### 3.3.3.2 Example of Operation

Shown below figure is examples for when executing one press program to turn the servo ON, return to home position and having loadcell calibration.

- Example of operation

- 1) Turn ON (operation enable) axis movement permission signal (ENMV).
- 2) Indicate the press program number (PC1 to PC32).
- 3) Turn the press program home position movement signal (PHOM) ON. During the movement to home position, the press program home position movement signal is kept ON. The press program home position signal (PORG) turns ON once the home position movement completes.
- 4) Turn the press program start signal (PSTR) on to execute the press program.
  - The press program execution signal (PRUN) turns ON while the press program is executed
  - \* Duration from program start till standby time pass after return stage
- 5) Each stage execution signal is kept ON while each stage in the press program is executed.
  - While in approaching stage executed = While in approaching operation signal (APRC)
  - While in probing stage executed = While in probing operation signal (SERC)
  - While in pressurizing stage (pressurize) executed = While in pressurizing operation (APRC)
  - While in pressurizing stage (stop) executed = While in pressurizing stop (PSTP)
- 6) Judgment made for pressurizing stop (PSTP ON).
  - The result is output in judgment OK signal (JDOK) and judgment NG signal (JDNG).
  - \* When judged NG, 094: Press Program Alarm (Detail Code [49: Position (distance) judgement NG] or [4A: Load judgement NG]) should also be output. [Refer to 8.4.2 Program Alarm]
- 7) Once each of decompressing and return stage is finished, the press program normal complete signal (PCMP) turns ON.

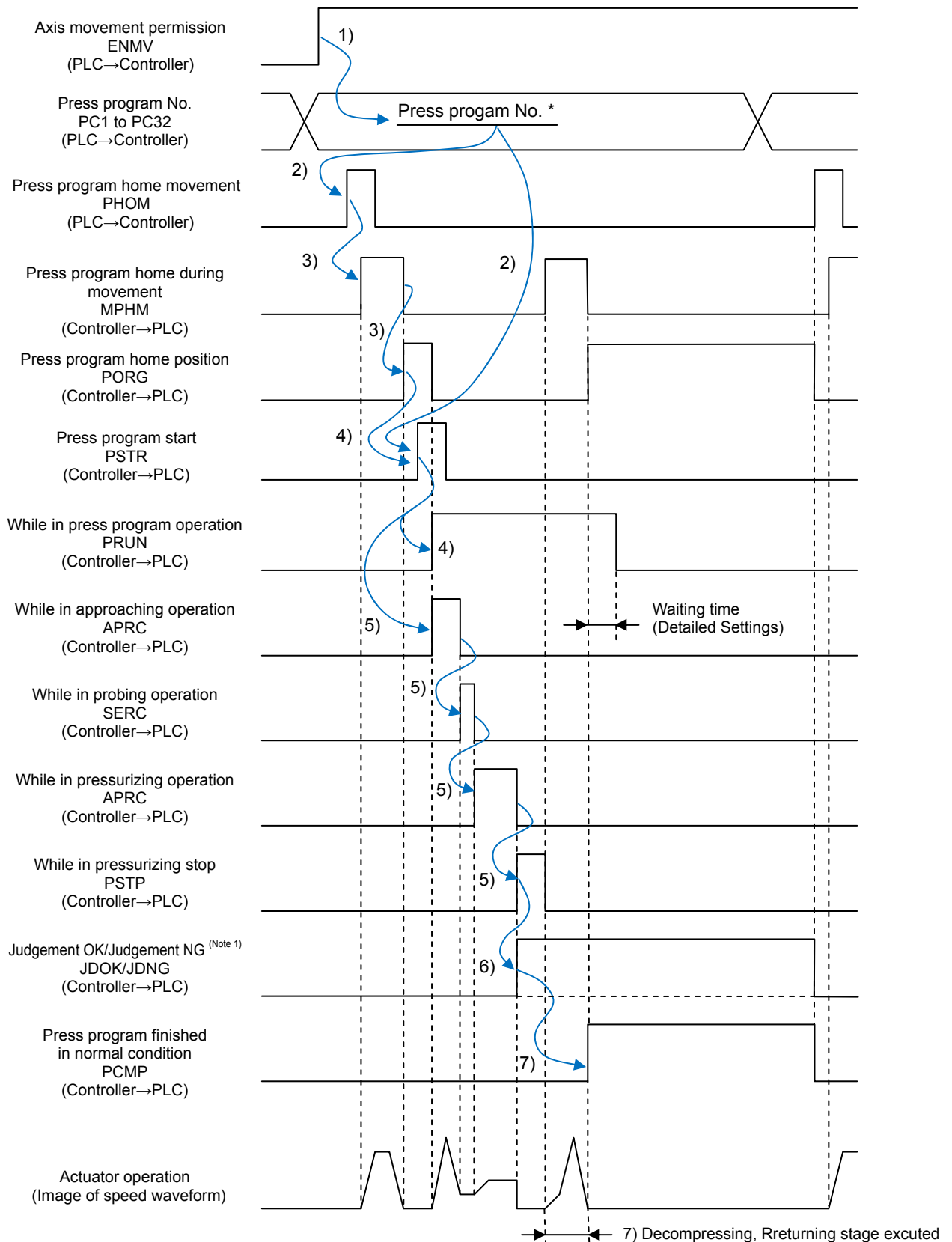

Note 1 When judged NG, 094: Press Program Alarm (Detail Code [49] or [4A]) should be output.

Note Have 6ms or more after the press program number input till turning PSTR ON. Even if having timer process of 6ms on PLC, it will be input to the controller at the same time and positioning may be held at another position. Establish the considering also the scan time of PLC.

## Chapter 4 Applicability to Fieldbus

Are applicable for the fieldbus shown in the list below. (It is the option which can be selected when purchasing)

It cannot be changed after the product is delivered.

Also, PIO cannot be equipped for the fieldbus type.

### ■ Type of Fieldbus

Fieldbus Name	Description	Details
DeviceNet	Control of the actuator is available with I/O communication using the control signals same as those for PIO or the numerical data communication.	Refer to the other ME0256 <sup>(Note1)</sup>
CC-Link		Refer to the other ME0254 <sup>(Note1)</sup>
PROFIBUS-DP		Refer to the other ME0258 <sup>(Note1)</sup>
CompoNet		Refer to the other ME0220 <sup>(Note1)</sup>
EtherCAT		Refer to the other ME0273 <sup>(Note1)</sup>
EtherNet/IP		Refer to the other ME0278 <sup>(Note1)</sup>
PROFINET IO		Refer to the other ME0333 <sup>(Note1)</sup>
MECHATROLINK- I / II <sup>(Note 2)</sup>	Control of the actuator is available with I/O communication using the control signals same as those for PIO or the numerical data communication.	Refer to the other ME0221 <sup>(Note1)</sup>

- Note 1
- Handled as a slave unit. For details of each network, check the Instruction Manuals of the master unit provided by the manufacturer and that of the installed PLC.
  - The Instruction Manuals describing how to use fieldbus are provided separately. Read them together with this manual.

- Note 2
- It is applicable only to remote I/O mode.

[Reference] Wiring Layout of Fieldbus

Follow the instruction manual of the master unit and PLC consists of each fieldbus for the details of how to perform connections.

1) DeviceNet Type

(Note) Prepare a terminal resistor separately when this controller is on the terminal.

Terminal resistor is required to be connected on the terminal.

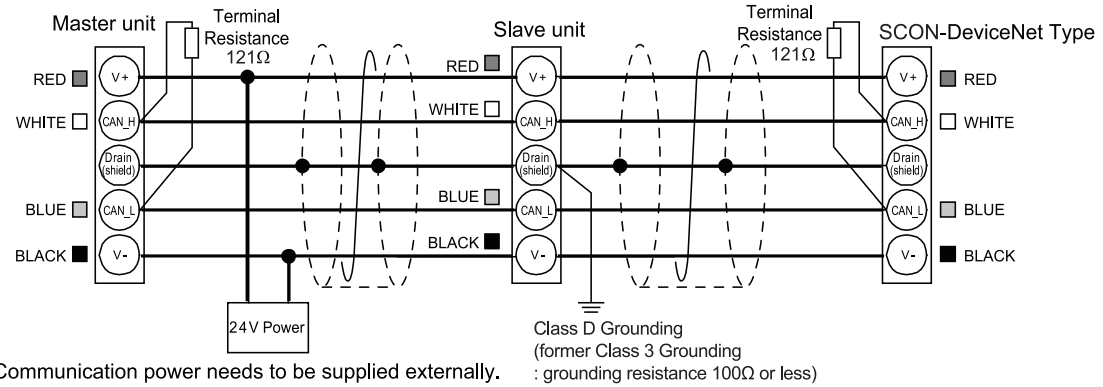

2) CC-Link Type

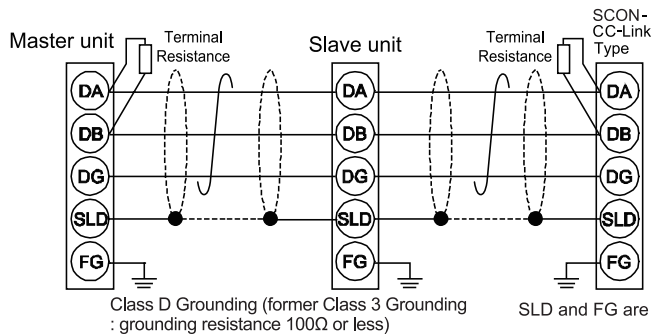

Terminal resistor is required to be connected on the terminal.

The terminal resistor differs depending on the type of the CC-Link dedicated cable.  
 Cable FANC-SBH...130Ω1/2W (CC-Link high performance cable)  
 Cable FANC-SB...110Ω1/2W (Dedicated for CC-Link Cable)

3) PROFIBUS-DP Type

Terminal resistor is required to be connected on the terminal.

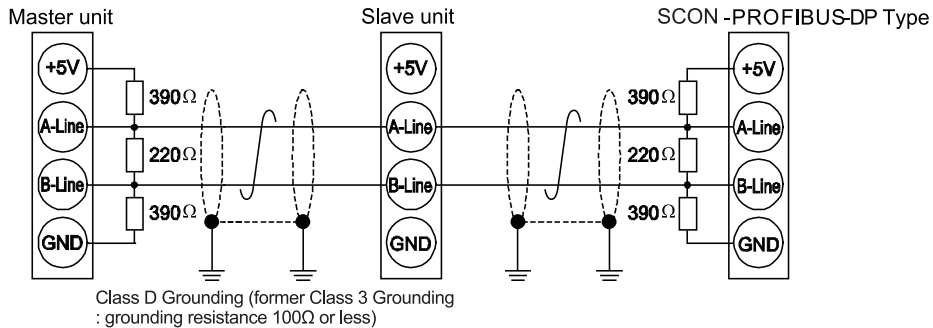



4) CompoNet Type

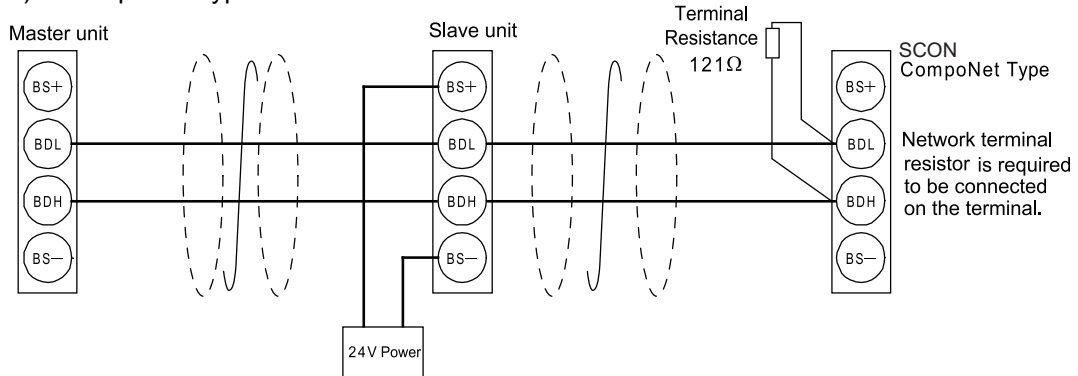

Power needs to be supplied separately for the slave devices that require communication power supply. At this time, there is no problem if applying communication power to the IAI controller.

5) EtherNet/IP Type

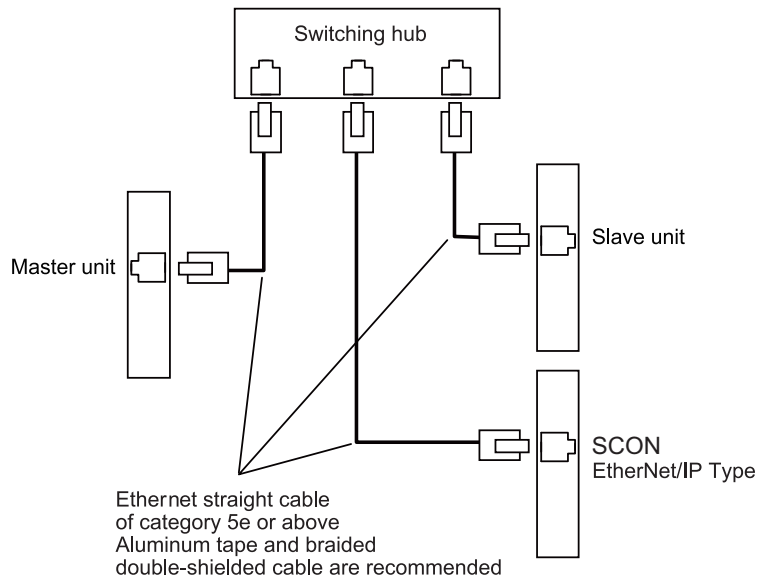

6) EtherCAT Type

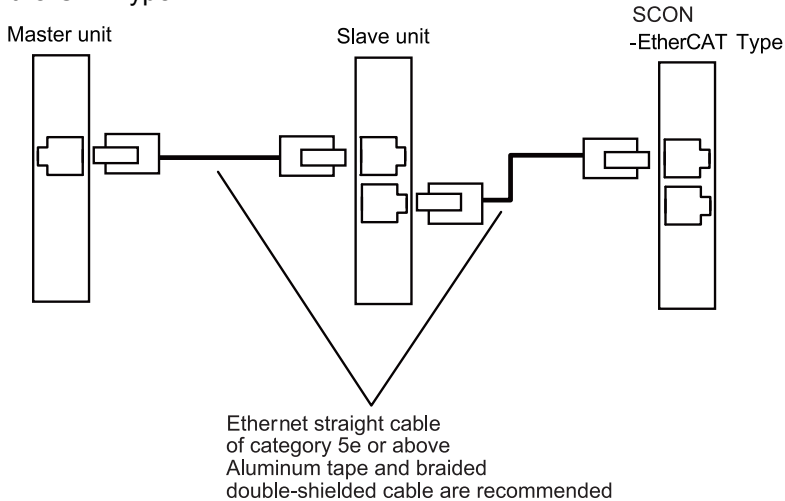

(Note) Terminal resistor is not necessary.

7) PROFINET-IO Type

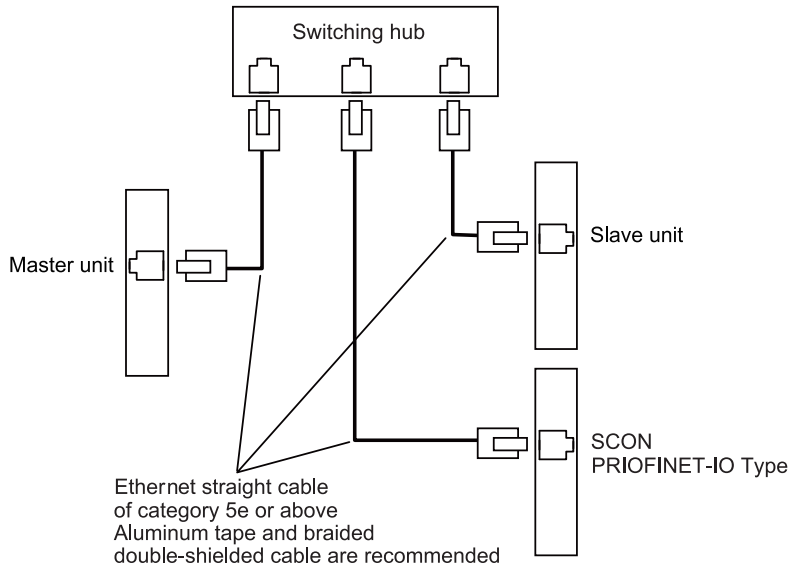

8) MECHATROLINK-III Type

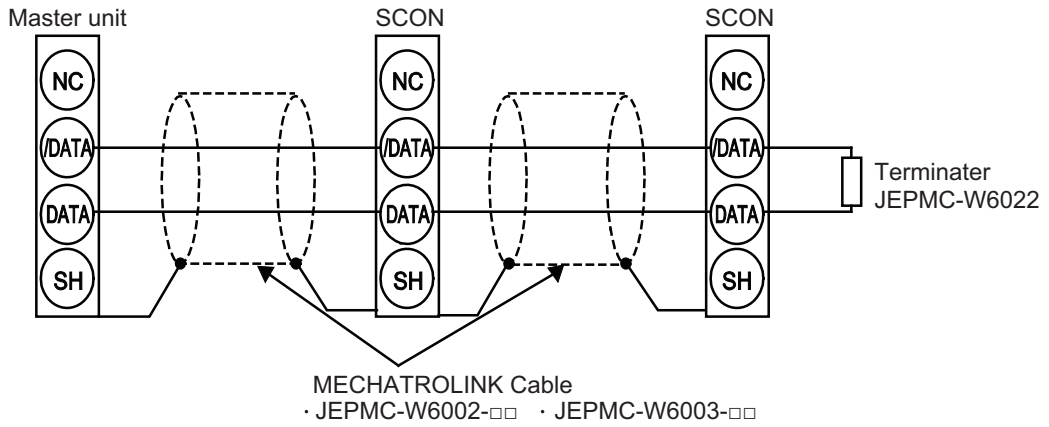

## Chapter 5 Feature of Multi-function Connector

In here, explains the feedback pulse output, analog output and serial communication 2 equipped in the multi-function connector (MF I/F).

### 5.1 Feedback Pulse Output

This controller can output the feedback pulse so connection can be established to such as a general-purposed load measurement tool.

The position detection data is output in the differential pulse (A-phase, B-phase and Z-phase: 2.5Mpps Max.). The host controller can read in the current position of the actuator in real time by using such as the counter feature.

6 types of feedback pulse train are available to select from. Set the pulse train format in Parameter No. 69 and active high/low in Parameter No. 70. Also, by establishing settings in Parameter No. 114 to 116, the electronic gear ratio different from the input pulse can be output.

 **Caution:**

- (1) It can be inactivated in User Parameter No. 68 “Feedback Pulse Valid/Invalid (Initial Setting)”. When it is not to be used, set it to Invalid.
- (2) When reading in this signal to the host controller and construct a closed loop, establish the setting with no logical contradiction.
- (3) Z-phase signal is output as it is when the actuator encoder is not the serial encoder. When it is the serial encoder, the range from 0 point (home) position to  $\pm 0.5$ deg of the mechanical angle is output as the Z-phase signal. This accuracy is guaranteed by the communication frequency with the encoder only when the number of the motor revolution is 100rpm or less.

#### 5.1.1 Setting

##### [1] Setting Feedback Pulse Output Effective

Set it if the feedback pulse is to be used.

No.	Name	Symbol	Unit	Input Range	Initial Value
68	Feedback Pulse Output	FPIO	-	0 to 1	1

You can select whether to enable or disable the feedback pulse output.

Setting 0: Enable

Setting 1: Disable

 **Caution:** Make this setting invalid if the feedback pulse is not output.

##### [2] Feedback Pulse Output to Motor Revolution Direction

It is to be set when required to switch between forward and reversed revolution of the feedback pulse output.

No.	Name	Symbol	Unit	Input Range	Initial Value
62	Direction of Pulse Count	FPIO	-	0 to 1	depends on the actuator

Setting 0: Forward (Output as forward pulse train when the actuator moves in the reversed direction against the home position)

Setting 1: Reversed revolution (Output as forward pulse train when the actuator moves in the toward the home position)

[3] Format Settings for Feedback Pulse

Set the format of output pulse in Parameter No.69 and active high/low in No. 70.

1) Feedback Pulse Train

No.	Name	Symbol	Unit	Input Range	Initial Value
69	Feedback Pulse Train	FBPT	-	0 to 2	0

Command Pulse String Mode	Input Terminal	In Normal Rotation	In Reverse Rotation	Setting Value of Parameter No. 69	
Negative Logic	Normal Rotation Pulse String	AFB•/AFB			2
	Reverse Rotation Pulse String	BFB•/BFB			
	The normal rotation pulse string shows the motor rotation amount in normal direction, and reverse rotation pulse string shows the motor rotation amount in reverse direction.				
	Pulse Train	AFB•/AFB			1
	Symbol	BFB•/BFB	Low	High	
	The command pulse shows the motor rotation amount and the command symbol shows the rotation direction.				
	A/B Phase Pulse String	AFB•/AFB			0
	BFB•/BFB				
The A/B Phase 4-fold Pulse with the phase difference of 90° shows the commands for the rotation amount and direction.					
Positive Logic	Normal Rotation Pulse String	AFB•/AFB			2
	Reverse Rotation Pulse String	BFB•/BFB			
	Pulse Train	AFB•/AFB			1
	Symbol	BFB•/BFB	High	Low	
	A/B Phase Pulse String	AFB•/AFB			0
	BFB•/BFB				
ZFB•/ZFB	<p>When the actuator encoder is other than the serial encoder, the Z-phase signal is output as it is. In the case of serial encoder, the range of <math>\pm 0.5^\circ</math> of mechanical angle from the point 0 position (origin), is output as the Z-phase signal.</p> <p>Only when the motor rpm is 100rpm or less, this accuracy can be guaranteed for the communication frequency with the encoder.</p> <p>* When the encoder pulse count is 16384 (Pulse/rev), it shows the serial encoder.</p>				

2) Feedback Pulse Form Polarity

No.	Name	Symbol	Unit	Input Range	Initial value
70	Feedback Pulse Form Polarity	FBPT	-	0 to 1	0

Setting 0: Positive Logic

Setting 1: Negative Logic

[4] Electric Gear Settings for Feedback Pulse

This is the parameter to determine the output pulse corresponding to the actuator movement amount. Determine the movement amount per pulse to define how many millimeters you would like the actuator to move with the output of 1 pulse.

Movement in line axis per pulse = Minimum output unit (1, 0.1, 0.01mm etc.) / pulse

User Parameter No.115/116 Electronic Gear (Feedback Pulse) Numerator/Denominator

No.	Name	Symbol	Unit	Input Range	Initial value (For reference)
115	Electronic Gear Numerator (Feedback Pulse)	FNUM	-	1 to 99999999	1
116	Electronic Gear Denominator (Feedback Pulse)	FDEN	-	1 to 99999999	1

The input range is from 1 to 4096 if the controller version is earlier than V0005.

■ Electronic Gear Formula:

$$\frac{\text{Electronic Gear Numerator (FNUM)}}{\text{Electronic Gear Denominator (FDEN)}} = \frac{\text{Ball Screw Lead Length [mm/rev]}}{\text{No. of Encoder Pulses [pulse/rev]}} \times \frac{1}{\text{Movement amount per pulse [mm]}}$$

■ Formula for velocity:

The velocity of the actuator is in proportion to the frequency of the output pulse.  
Velocity = Movement amount per pulse × Output Pulse Frequency [Hz]

■ Examples of electronic gear calculations:

When outputting the feedback pulse of the actuator equipped with an encoder with 10mm ball screw lead and 16384pulse/rev in 0.02mm movement per pulse:

$$\begin{aligned} \frac{\text{Electronic Gear Numerator (FNUM)}}{\text{Electronic Gear Denominator (FDEN)}} &= \frac{\text{Ball Screw Lead Length [mm/rev]}}{\text{No. of Encoder Pluses [pulse/rev]}} \times \frac{1}{\text{Movement amount per pulse [mm]}} \\ &= \frac{10}{16384} \times \frac{100}{2} = \frac{125}{4096} \end{aligned}$$

The electric gear numerator (FNUM) = 125, electric gear denominator (FDEN) = 4096 will give the output of 1 pulse in 0.02mm of the actuator move.

**⚠ Caution:**

- The fraction has to be completely reduced so both the electric gear numerator (FNUM) and electric gear denominator (FDEN) can be 99999999 or less (4096 or less when the controller version is earlier than V0005) and make them to be integral numbers. (Do not stop reducing the fraction on the way.) (Do not stop reducing the fraction on the way.)
- FNUM and FDEN on the line axis have to satisfy the following relative formulas.

$$2^{27} \geq \frac{\text{Stroke Length [mm]}}{\text{Ball Screw Lead Length [mm/rev]}} \times \text{No. of Encoder Pluses [pulse]} \times \frac{\text{FDEN}}{\text{FNUM}}$$

Also, there are some limitations as follows when the controller version is earlier than V0005.

$$2^{31} \geq \frac{\text{Stroke Length [mm]}}{\text{Ball Screw Lead Length [mm/rev]}} \times \text{No. of Encoder Pluses [pulse]} \times \text{FNUM}$$

$$2^{31} \geq \frac{\text{Stroke Length [mm]}}{\text{Ball Screw Lead Length [mm/rev]}} \times \text{No. of Encoder Pluses [pulse]} \times \text{FDEN}$$

- Do not attempt to establish a setting that gives a condition that electronic gear numerator (FNUM) > electronic gear denominator (FDEN).  
The formula is as shown above and the pulse output is based on the encoder pulse, therefore evenly allocated feedback pulse responding to the velocity cannot be output.

## 5.2 Analog Output of Load Data

This controller can output the loadcell measurement values in analog (ratio to the loadcell rated capacity) so connection can be established to such as a general-purposed load measurement tool.

### 5.2.1 Specification

Item	Specification	Unit	Remarks	
Accuracy	±1.0	%FSR	It is not include loadcell accuracy.	
Load Resistance	10 to 600	Ω		
Output current	4 to 20	mA	Output Current Value [mA]	Load Value [%]*
			20.00	130.00
			19.00	120.00
			18.00	110.00
			17.00	100.00
			16.00	90.00
			15.00	80.00
			14.00	70.00
			13.00	60.00
			12.00	50.00
			11.00	40.00
			10.00	30.00
			9.00	20.00
			8.00	10.00
			7.00	0.00
			6.00	-10.00
5.00	-20.00			
4.00	-30.00			

\* The ratio to the loadcell rated capacity is output in current.

(Example) For rated capacity 20000[N] of the loadcell

Load of 20000 [N] detected: Output current = 17.00 [mA]

Load of 10000 [N] detected: Output current = 12.00 [mA]

Load of 5000 [N] detected : Output current = 9.50 [mA]

### 5.2.2 Setting

Establish the setting when using the analog output of the load data.

No.	Name	Symbol	Unit	Input Range	Initial Value
180	DAC Output	FPIO	-	0 to 1	1

You can select whether to enable or disable the analog output.

Setting 0: Enable

Setting 1: Disable

### 5.2.3 Rated Capacity of Loadcell Mounted to Each Actuator

Actuator Model	Loadcell Rated Capacity [N]
RCS3-RA4R	200
RCS3-RA6R	600
RCS3-RA7R, RCS3-RA8R	2000
RCS3-RA10R	6000
RCS2-RA13R	20000
RCS3-RA15R, RCS3-RA20R	50000

### 5.3 Serial Communication 2 (SIO2)

This controller is equipped with SIO2 line as well as SIO line for teaching so connection can be established to such as a general-purposed touch panel. Communication conducted with Modbus protocol like one for teaching.

#### 5.3.1 Specification

Item	Specification	Unit	Remarks
Communication System	Based on RS485		
Baud Rate	9600, 14400, 19200, 28800, 38400, 57600, 76800, 115200, 230400	bps	
Protocol	Modbus		Refer to MJ0162 Modbus Instruction Manual
Hot Swapping	Unavailable		Description of the multi-function connector while the power is on cannot be conducted.

#### 5.3.2 Setting

##### [1] Baud rate setting

Establish the SIO2 baud rate setting in Parameter No. 169.

No.	Name	Symbol	Unit	Input Range	Initial Value
169	Select the SIO2 Baud Rate	BRS2	bps	9600 to 230400	38400

Apply the baud rate of the connecting unit.

##### [2] Unit Number Setting

Set the unit number of SIO2 in Parameter No. 172.

No.	Name	Symbol	Unit	Input Range	Initial Value
172	SIO2 Slave address	MSA2	-	0 to 16	0

Setting 0: Unit number setting same as SIO1 (teaching port)

Setting 1 to 16

 **Caution:** When connecting the PC software and another device, connect the PC software to SIO connector (teaching port) and the other device to SIO2. In such a case, use the device connected to SIO2 only for data readout and monitoring. (Having it for operation command and data writing could cause operation error.)

## Chapter6 Absolute Type

### 6.1 Absolute Reset

The controller of absolute specification holds encoder position information by battery backup. It is not necessary to perform the home-return operation every time the power is turned ON. In order to hold the encoder correct position information, absolute reset is required. Provide absolute reset in the following cases:

- (1) Initial activation
- (2) Replacement of absolute battery
- (3) Disconnection of encoder cable from controller
- (4) Absolute encoder error (2) (alarm code: 0EE) is issued

The absolute reset is performed by using a PC software. Described below is the procedure.

#### [1] Absolute Reset Procedure

- 1) Connect the controller with the actuator. [Refer to Chapters 1 and 2.]
- 2) Connect the absolute battery (Enclosed battery if starting up for the first time, new battery if replacing) to the absolute battery connecting connector on the front panel of the controller. [Refer to 6.2]
- 3) Connect the cable for PC software, set the operation mode setting switch on the front panel of the controller to MANU side, and then turn the controller ON.
- 4) The absolute encoder error appears. Perform alarm reset.
- 5) Perform home-return operation. Once the home return is complete, the point of origin is memorized at the same time the origin point is established.

Shown below is an procedure 4), and 5) of the screen.

- 1) An alarm window appears on the PC software screen. A message asking if you would like to reset the alarm is shown. Press **Yes** button.

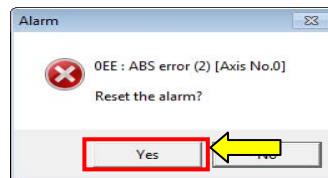

- 2) Select the operation/monitor window and press **Servo** → **Home**.

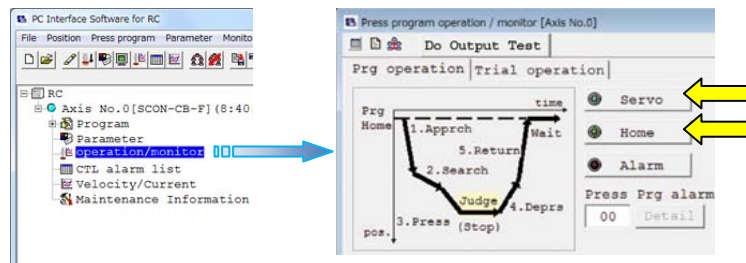



## 6.2 Absolute Battery

An absolute battery is enclosed with the absolute type controller.  
Connect the battery to the absolute battery connector on the front panel of the controller.

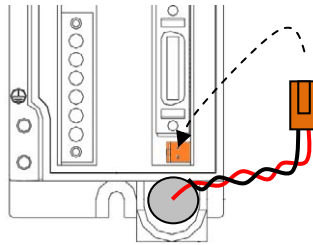

### 6.2.1 Absolute Encoder Backup Specifications

Item		Specifications
Battery classification		Thionyl chloride lithium batteries
Battery manufacturer's name		TOSHIBA HOME APPLIANCES CORP
Battery model (IAI model)		AB-5 (with Battery Holder: AB-5-CS2)
Battery nominal voltage		3.6V
Current standard capacity		2000mAh
Reference for battery replacing timing <sup>(Note 1)</sup> (Ambient temperature 40°C)		2 years after use (If left unused without power supply to controller) 4 years after use (If 50% of time with power supply to controller)
Error detection	Output of (*ALM <sup>(Note 2)</sup> )	2.5V (Reference value)
	Output of warning (*ALML <sup>(Note 2)</sup> )	3.1V (Reference value)
	Warning → Reference for time suspended after alert till alarm	7 days if the controller is operated continuously at 20°C. 2.5 days if the controller is operated continuously at 40°C.
Absolute data retaining duration at battery replacement		15 minutes (Have the replacing work done within this time.)

Note 1 Replace the battery regularly.

Note 2 \*ALM and \*ALML are the signals of active low.

After the power is supplied to the controller, they are usually ON and turned OFF when an error is detected.

If the alarm is generated, it will be necessary to absolute reset after the battery replacement.

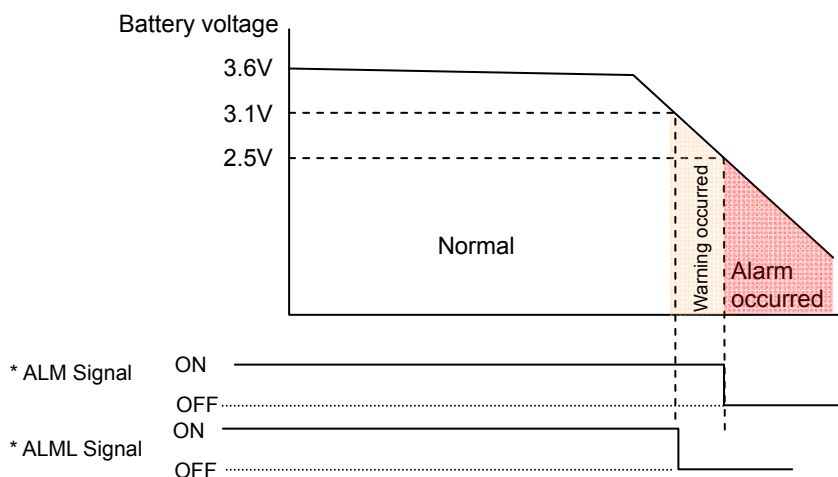

## 6.2.2 Replacement of Absolute Battery

For the battery replacement, remove the battery connector while keeping the power to the controller ON, and change the battery installed in the battery holder.

**Caution :** To replace the old absolute battery with a new one with the controller power being OFF, complete the replacement within 15 minutes from the removal of the old battery. The absolute data may get lost if it exceeds 15minutes.

[Removal]

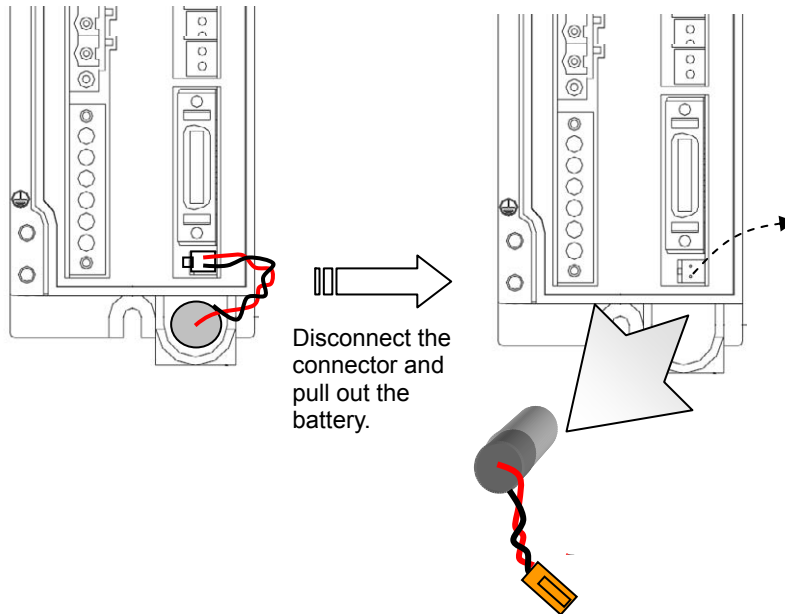

[Attachment]

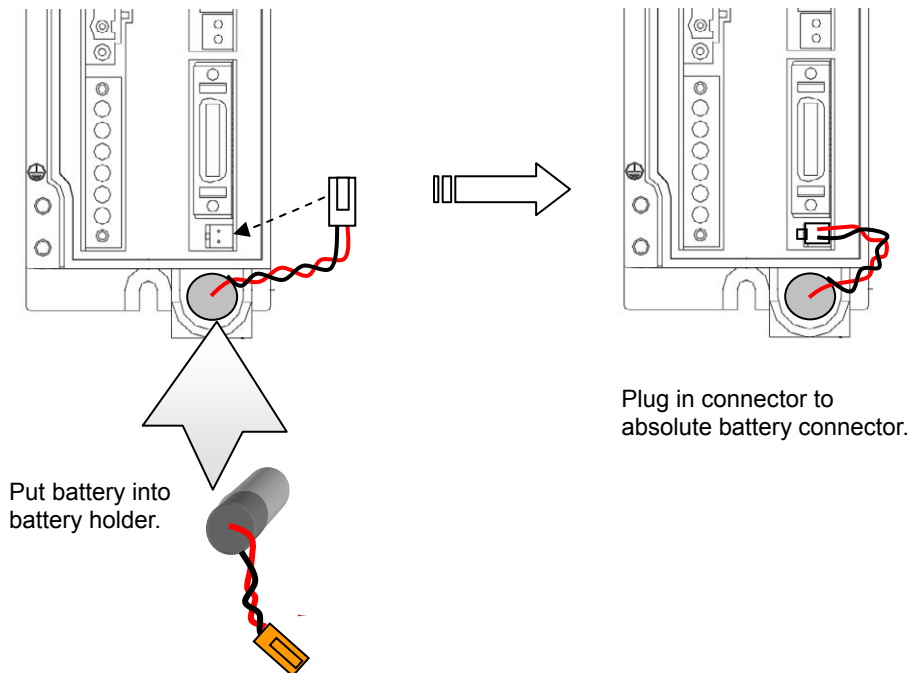

## Chapter 7 Parameter

Parameters are the data to set up considering the system and application.

When a change is required to the parameters, make sure to back up the data before the change so the settings can be returned anytime.

Also, for the purpose of rapid recovery after the investigation of failure unit or replacing the controller, keep data backup or memo also after the parameter change.

The change to the parameters will be activated after they are edited, written to the flash FeRAM, then either software reset or reboot of the power. It will not be active only with writing on the teaching tool.



**Warning :** Parameter setting has great influences on operations of the controller. Incorrect parameter setting may not only cause malfunction or failure of the controller to occur but also people and assets to be exposed to risk. The controller is configured to be applicable to normal operation at shipment. Before providing certain change or setting for the controller to be fit to your system, understand the control methods of the controller sufficiently. Please contact us if you have anything unclear. Do not turn OFF the power to the controller during the parameter writing.

## 7.1 Parameter List

The categories in the table below indicate whether parameters should be set or not. There are five categories as follows:

- A : Check the settings before use.
- B : Use parameters of this category depending on their uses.
- C : Use parameters of this category with the settings at shipments leaving unchanged as a rule. Normally they may not be set.
- D : Parameters of the category are set at shipment in accordance with the specification of the actuator. Normally they may not be set.
- E : Parameters of the category are exclusively used by us for convenience of production. Changing their settings may not only cause the actuator to operate improperly but also to be damaged. So, never change the setting of the parameters.

Category do not appear on the teaching tool. Also, the unused parameter numbers are not mentioned in the list.

No.	Category	Name	Symbol	Unit	Input Range	Default factory setting	Relevant sections
1	B	Zone 1 +	ZNM1	mm	-9999.99 to 9999.99	Actual stroke on + side <sup>(Note 1)</sup>	7.2 [1]
2	B	Zone 1 -	ZNL1	mm	-9999.99 to 9999.99	Actual stroke on - side <sup>(Note 1)</sup>	7.2 [1]
3	A	Soft limit +	LIMM	mm	-9999.99 to 9999.99	Actual stroke on + side <sup>(Note 1)</sup>	7.2 [2]
4	A	Soft limit -	LIML	mm	-9999.99 to 9999.99	Actual stroke on - side <sup>(Note 1)</sup>	7.2 [2]
7	C	Servo gain number	PLGO	-	0 to 31	In accordance with actuator <sup>(Note 1)</sup>	7.2 [3] 7.3
8	B	Default velocity	VCMD	mm/s	1 to Actuator max. speed	Rated actuator speed <sup>(Note 1)</sup>	7.2 [4]
9	B	Default acceleration/deceleration	ACMD	G	0.01 to Actuator's max. acceleration/deceleration	Rated actuator's acceleration/deceleration <sup>(Note 1)</sup>	7.2 [5]
13	C	Current-limiting value during home return	ODPW	%	1 to 300	In accordance with actuator <sup>(Note 1)</sup>	7.2 [6]
14	E	Dynamic brake	FSTP	-	0: Enabled, 1: Disabled	1	7.2 [7]
16	B	SIO baud rate	BRSL	bps	9600 to 230400	38400	7.2 [8]
17	B	Minimum delay time for slave transmitter activation	RTIM	msec	0 to 255	5	7.2 [9]
18	E	Home position check sensor input polarity	AIOF	-	0 to 2	In accordance with actuator <sup>(Note 1)</sup>	7.2 [10]
19	E	Overrun sensor input polarity	AIOF	-	0 to 2	In accordance with actuator <sup>(Note 1)</sup>	7.2 [11]
20	E	Creep sensor input polarity	AIOF	-	0 to 2	In accordance with actuator <sup>(Note 1)</sup>	7.2 [12]
21	B	Servo ON input disable	FPIO	-	0: Enabled, 1: Disabled	0	7.2 [13]
22	C	Home return offset level	OFST	mm	0.00 to 9999.99	In accordance with actuator <sup>(Note 1)</sup>	7.2 [14]
23	B	Zone 2 +	ZNM2	mm	-9999.99 to 9999.99	Actual stroke on + side <sup>(Note 1)</sup>	7.2 [1]
24	B	Zone 2 -	ZNL2	mm	-9999.99 to 9999.99	Actual stroke on - side <sup>(Note 1)</sup>	7.2 [1]
25	E	PIO pattern selection	IOPN	-	0 to 7	0	7.2 [16]
26	B	PIO jog velocity	IOJV	mm/s	1 to Actuator max. speed	100	7.2 [17]
31	C	Velocity loop proportional gain	VLPG	-	1 to 99999999	In accordance with actuator <sup>(Note 1)</sup>	7.2 [18] 7.3
32	C	Velocity loop integral gain	VLPT	-	1 to 99999999	In accordance with actuator <sup>(Note 1)</sup>	7.2 [19] 7.3
33	C	Torque filter time constant	TRQF	-	0 to 2500	In accordance with actuator <sup>(Note 1)</sup>	7.2 [20] 7.3
34	C	Press velocity	PSHV	mm/s	1 to Actuator's max. pressing speed	In accordance with actuator <sup>(Note 1)</sup>	7.2 [21]
35	C	Safety velocity	SAFV	mm/s	1 to 250 (max. for actuator of 250 or less)	100	7.2 [22]
40	C	Home-return input disable	FPIO	-	0: Enabled, 1: Disabled	0	7.2 [23]
41	C	Operating-mode input disable	FPIO	-	0: Enabled, 1: Disabled	0	7.2 [24]
42	C	Enable function	FPIO	-	0: Enabled, 1: Disabled	1	7.2 [25]
45	B	Silent interval magnification	SIVM	time	0 to 10	0	7.2 [26]
47	B	PIO jog velocity 2	IOV2	mm/s	1 to Actuator max. speed	100	7.2 [17]
48	B	PIO inch distance	IOID	mm	0.01 to 1.00	0.1	7.2 [28]
49	B	PIO inch distance 2	IOD2	mm	0.01 to 1.00	0.1	7.2 [28]
54	C	Current-control width number	CLPF	-	0 to 15	In accordance with actuator <sup>(Note 1)</sup>	7.2 [29]

No.	Category	Name	Symbol	Unit	Input Range	Default factory setting	Relevant sections
62	B	Pulse count direction	FPIO	-	0 : Normal rotation pulse train 1 : Reversed rotation pulse train	In accordance with actuator <sup>(Note 1)</sup>	5.1.1
68	B	Feedback pulse output	FPIO	-	0: Enabled, 1: Disabled	1	5.1.1
69	B	Feedback pulse train	FBPT	-	0 to 2	0 (A/B Phase Pulse String)	5.1.1
70	B	Feedback pulse form polarity	FBPT	-	0: Positive Logic 1: Negative Logic	0	5.1.1
71	B	Feed forward gain	PLFG	-	0 to 100	0	7.2 [34] 7.3
72	E	Timer period for emergency stop relay fusing monitor	EMWT	msec	0 to 60000	3000	7.2 [35]
73	D	Encoder voltage level	EVLV	-	0 to 3	Depending on encoder cable length <sup>(Note 1)</sup>	7.2 [36]
74	C	PIO power supply supervision	FPIO	-	0: Enabled, 1: Disabled	0	7.2 [37]
75	D	Electromagnetic brake power monitor	FSTP	-	0: Disabled, 1: Enabled	In accordance with actuator <sup>(Note 1)</sup>	7.2 [38]
76	D	Belt breaking sensor input polarity	AIOF	-	0 to 2	In accordance with actuator <sup>(Note 1)</sup>	7.2 [39]
77	D	Ball screw lead length	LEAD	mm	0.01 to 999.99	In accordance with actuator <sup>(Note 1)</sup>	7.2 [40]
84	A	Field bus operation mode <sup>(Note 2)</sup>	FMOD	-	0 to 1	Separate volume	Separate volume
85	A	Field bus node address <sup>(Note 2)</sup>	NADR	-	0 to 65535	Separate volume	Separate volume
86	A	Field bus baud rate <sup>(Note 2)</sup>	FBRS	-	0 to 4	Separate volume	Separate volume
87	E	Network type <sup>(Note 2)</sup>	NTYP	-	0 to 8	Separate volume	Separate volume
88	D	Software limit margin	SLMA	mm	0 to 9999.99	In accordance with actuator <sup>(Note 1)</sup>	7.2 [45]
89	D	Allowable time of exceeding torque allowing continuous pressing	PSCT	sec	0 to 300	In accordance with actuator <sup>(Note 1)</sup>	7.2 [46]
90	C	Field I/O format <sup>(Note 2)</sup>	FPIO	-	0 to 3	Separate volume	Separate volume
94	C	Pressing operation using force sensor gain	FRCG	-	100 to 999999	In accordance with actuator <sup>(Note 1)</sup>	7.2 [48]
95	C	Force judgment margin +	FJMM	%	1 to Maximum Pressing Force	In accordance with actuator <sup>(Note 1)</sup>	7.2 [49]
96	C	Force judgment margin -	FJML	%	1 to Maximum Pressing Force	In accordance with actuator <sup>(Note 1)</sup>	7.2 [49]
111	B	Calendar function	FRTC	-	0: Does not use the calendar timer 1: Use the calendar timer	1	7.2 [50]
113	B	Monitoring frequency	FMNT	msec	1 to 1000	1	7.2 [51]
115	B	Electrical gear numerator (Feedback pulse)	FNUM	-	1 to 99999999 <sup>(Note 3)</sup>	1	5.1.1
116	B	Electronic gear denominator (Feedback pulse)	FDEN	-	1 to 99999999 <sup>(Note 3)</sup>	1	5.1.1
117	B	Automatic loadcell calibration at start	FFRC	-	0: Does not perform 1: Perform	1	3.3.2[7]
119	B	Loadcell calibration time	CLBT	msec	1 to 9999	10	3.3.2[7]
120	C	Servo gain number 1	PLG1	-	0 to 31	In accordance with actuator <sup>(Note 1)</sup>	7.2 [3] 7.3
121	C	Feed forward gain 1	PLF1	-	0 to 100	In accordance with actuator <sup>(Note 1)</sup>	7.2 [34]
122	C	Velocity loop proportional gain 1	VLG1	-	1 to 27661	In accordance with actuator <sup>(Note 1)</sup>	7.2 [18] 7.3
123	C	Velocity loop integral gain 1	VLT1	-	1 to 217270	In accordance with actuator <sup>(Note 1)</sup>	7.2 [19] 7.3
124	C	Torque filter time constant 1	TRF1	-	0 to 2500	In accordance with actuator <sup>(Note 1)</sup>	7.2 [20] 7.3
125	C	Current control width number 1	CLP1	-	0 to 15	In accordance with actuator <sup>(Note 1)</sup>	7.2 [29] 7.3
126	C	Servo gain number 2	PLG2	-	0 to 31	In accordance with actuator <sup>(Note 1)</sup>	7.2 [3] 7.3
127	C	Feed forward gain 2	PLF2	-	0 to 100	In accordance with actuator <sup>(Note 1)</sup>	7.2 [34]
128	C	Velocity loop proportional gain 2	VLG2	-	1 to 27661	In accordance with actuator <sup>(Note 1)</sup>	7.2 [18] 7.3
129	C	Velocity loop integral gain 2	VLT2	-	1 to 217270	In accordance with actuator <sup>(Note 1)</sup>	7.2 [19] 7.3
130	C	Torque filter time constant 2	TRF2	-	0 to 2500	In accordance with actuator <sup>(Note 1)</sup>	7.2 [20] 7.3

No.	Category	Name	Symbol	Unit	Input Range	Default factory setting	Relevant sections
131	C	Current control width number 2	CLP2		0 to 15	In accordance with actuator <sup>(Note 1)</sup>	7.2 [29] 7.3
132	C	Servo gain number 3	PLG3	-	0 to 31	In accordance with actuator <sup>(Note 1)</sup>	7.2 [3] 7.3
133	C	Feed forward gain 3	PLF3	-	0 to 100	In accordance with actuator <sup>(Note 1)</sup>	7.2 [34]
134	C	Velocity loop proportional gain 3	VLG3	-	1 to 27661	In accordance with actuator <sup>(Note 1)</sup>	7.2 [18] 7.3
135	C	Velocity loop integral gain 3	VLT3	-	1 to 217270	In accordance with actuator <sup>(Note 1)</sup>	7.2 [19] 7.3
136	C	Torque filter time constant 3	TRF3	-	0 to 2500	In accordance with actuator <sup>(Note 1)</sup>	7.2 [20] 7.3
137	C	Current control width number 3	CLP3	-	0 to 15	In accordance with actuator <sup>(Note 1)</sup>	7.2 [29] 7.3
138	C	Servo gain switchover time constant	GCFT	ms	10 to 2000	10	7.2 [73]
139	A	Home preset value	PRST	mm	-9999.99 to 9999.99	In accordance with actuator <sup>(Note 1)</sup>	7.2 [74]
140	B	IP address	IPAD	-	0.0.0.0 to 255.255.255.255	192.168.0.1	Separate volume
141	B	Subnet mask	SNMK	-	0.0.0.0 to 255.255.255.255	255.255.255.0	Separate volume
142	B	Default gateway	DFGW	-	0.0.0.0 to 255.255.255.255	0.0.0.0	Separate volume
143	B	Overload level ratio	OLWL	%	50 to 100	100	7.2 [78]
147	B	Total movement count target value	TMCT	Times	0 to 999999999	0 (Disabled)	7.2 [79]
148	B	Total operated distance target value	ODOT	m	0 to 999999999	0 (Disabled)	7.2 [80]
151	B	Light error alarm output select	FSTP	-	0: 1) Output of battery voltage drop warning, 2) Driver overload warning 3) Output when number of FAN revolution has dropped. 1: Output of message level alarm	0	7.2 [81]
163	C	FB half direct mode speed unit	FCNS	N/mm	1 to 99999	In accordance with actuator <sup>(Note 1)</sup>	7.2 [82]
164	C	Nominal rigidity	FCBW	rad/s	1 to 99	10	7.2 [83]
165	B	Force control band	SDDT	ms	0 to 10000	0	7.2 [84]
169	B	Select SIO2 baud rate	BRS2	bps	9600 to 230400	38400	7.2 [85]
170	B	Minimum delay time for slave transmitter activation	RTM2	ms	0 to 255	5	7.2 [86]
171	B	SIO2 Silent interval magnification	SIM2	Time	0 to 10	0	7.2 [87]
172	B	SIO2 slave address	MSA2		0 to 16	0	7.2 [88]
173	B	Force control transition threshold	FCTH	%	10 to 90	In accordance with actuator <sup>(Note 1)</sup>	7.2 [89]
174	C	Force gains 1	FRG1	-	100 to 999999	In accordance with actuator <sup>(Note 1)</sup>	7.2 [48]
175	C	Force gains 2	FRG2	-	100 to 999999	In accordance with actuator <sup>(Note 1)</sup>	7.2 [48]
176	C	Force gains 3	FRG3	-	100 to 999999	In accordance with actuator <sup>(Note 1)</sup>	7.2 [48]
177	C	Load detection Filter	LDFT	ms	1 to 10	3	7.2 [91]
178	B	Return operation initial value at press program alarm	FPRS	-	0: Return to home 1: Stop at the point	0	7.2 [92]
179	B	Return operation initial value at press program compulsory complete	FPRS	-	0: Return to home 1: Stop at the point	0	7.2 [93]
180	B	DAC output	FPIO	-	0: Enabled, 1: Disabled	1	7.2 [94]
184	B	Regenerative control select	RDSL	-	1: ~750W 2: 3000W ~	In accordance with actuator <sup>(Note 1)</sup>	7.2 [95]

Note 1 The setting values vary in accordance with the specification of the actuator.

At shipment, the parameters are set in accordance with the specification.

Note 2 These parameters are exclusively used for the fieldbus. Set the parameters according to the Instruction Manual a separate volume [Refer to chapter 4 for details]

Note 3 The input range is from 1 to 4096 if the controller version is earlier than V0005.

## 7.2 Detail Explanation of Parameters

**⚠ Caution:** If parameters are changed, provide software reset or reconnect the power to reflect the setting values.

- [1] Zone 1+, Zone 1- (Parameter No.1, No.2)  
 Zone 2+, Zone 2- (Parameter No.23, No.24)

No.	Name	Symbol	Unit	Input Range	Default factory setting
1	Zone 1+	ZNM1	mm (deg)	-9999.99 to 9999.99	Actual stroke on + side
2	Zone 1-	ZNL1	mm (deg)	-9999.99 to 9999.99	Actual stroke on - side
23	Zone 2+	ZNM2	mm (deg)	-9999.99 to 9999.99	Actual stroke on + side
24	Zone 2-	ZNL2	mm (deg)	-9999.99 to 9999.99	Actual stroke on - side

These parameters are used set the zone in which zone signal (ZONE1 or ZONE2) turns ON in a mode other than PIO patterns 1 to 3 (ZONE2 is valid only in the pulse-train control mode). The minimum setting unit is 0.01mm (deg).  
 If a specific value is set to both zone setting + and zone setting -, the zone signal is not output. A setting sample is shown below.

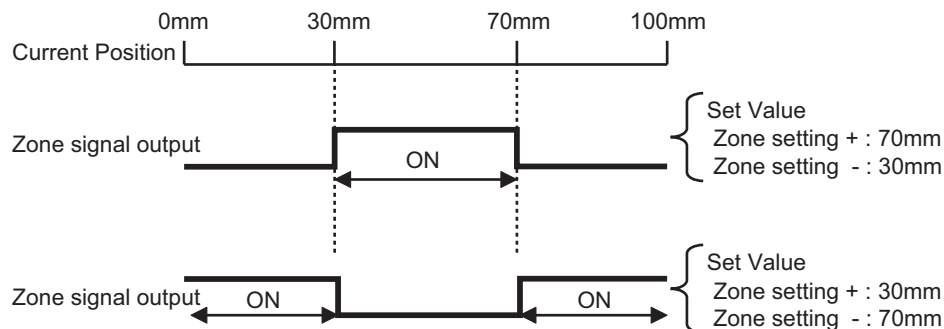

**⚠ Caution:** The zone detection range would not output unless the value exceeds that of the minimum resolution (actuator lead length / No. of Encoder Pluses).

## [2] Soft limit +, Soft limit – (Parameter No.3, No.4)

No.	Name	Symbol	Unit	Input Range	Default factory setting
3	Soft limit +	LIMM	mm (deg)	-9999.99 to 9999.99	Actual stroke on + side
4	Soft limit –	LIML	mm (deg)	-9999.99 to 9999.99	Actual stroke on - side

0.3mm (deg) is added to the outside of the effective actuator stroke for the setting at the delivery (since there would be an error at the end of effective stroke if set to 0). Change the setting if required for the cases such as when there is interference or to prevent a crash, or when using the actuator with slightly exceeding effective stroke in the operational range. An incorrect soft limit setting will cause the actuator to collide into the mechanical end, so exercise sufficient caution.

The minimum setting unit is 0.01mm.

(Note) To change a soft limit, set a value corresponding to 0.3mm outside of the effective stroke.

Example) Set the effective stroke to between 0mm to 80mm

Parameter No.3 (positive side) 80.3

Parameter No.4 (negative side) -0.3

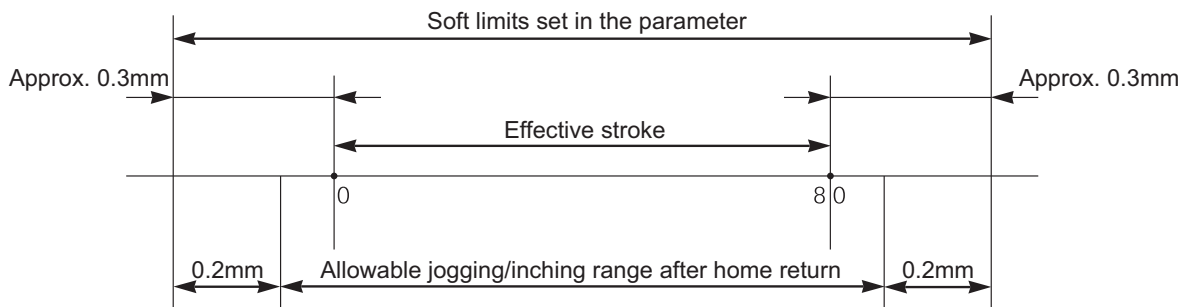

The operational range for jog and inching after the home return is 0.2mm less than the set value. Alarm Code 0D9 [Soft Limit Over Error] will be generated when the set value exceeded the value (0 when shipped out) set in Parameter No.88 [Software Limit Margin]. If the setting is not done in Parameter No.88, the value set in this parameter become the detection value for Alarm Code 0D9 [Soft Limit Over Error].



[3] Servo Gain Number (Parameter No.7)

No.	Name	Symbol	Unit	Input Range	Default factory setting
7	Servo gain number	PLGO	-	0 to 31	In accordance with actuator

The servo gain is also called position loop gain or position control system proportion gain. The parameter defines the response when a position control loop is used. Increasing the set value improves the tracking performance with respect to the position command. However, increasing the parameter value excessively increases the changes of overshooting. When the set value is too low, the follow-up ability to the position command is degraded and it takes longer time to complete the positioning. For a system of low mechanical rigidity or low natural frequency (every object has its own natural frequency), setting a large servo gain number may generate mechanical resonance, which then cause not only vibrations and/or noises but also overload error to occur.

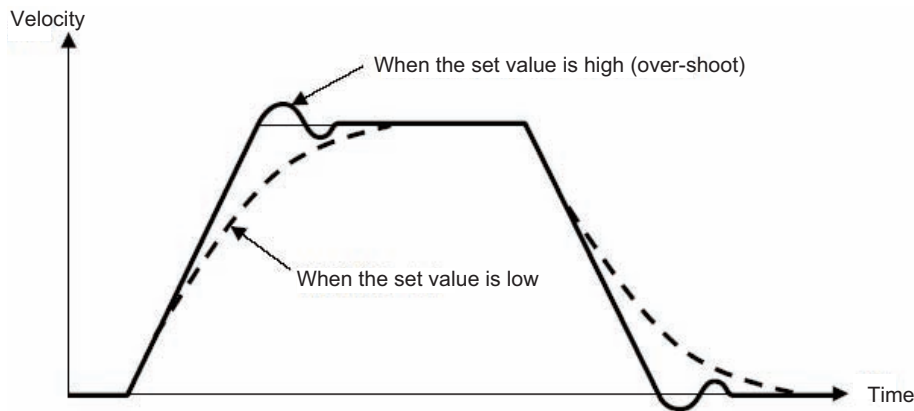

[4] Default Velocity (Parameter No.8)

No.	Name	Symbol	Unit	Input Range	Default factory setting
8	Default velocity	VCMD	mm/s (deg/s)	1 to Actuator's max. verocity	Rated actuator speed

The factory setting is the rated velocity of the actuator. This value will be written automatically to the speed setting of the press program as the initial value.

[5] Default Acceleration/Deceleration (Parameter No.9)

No.	Name	Symbol	Unit	Input Range	Default factory setting
9	Default acceleration/deceleration	ACMD	G	0.01 to actuator's max. acceleration/ deceleration	Rated actuator's acceleration/ deceleration

The factory setting is the rated acceleration/deceleration of the actuator. This value will be written automatically to the acceleration/deceleration setting of the press program as the initial value.

### [6] Current-limiting Value during Home Return (Parameter No.13)

No.	Name	Symbol	Unit	Input Range	Default factory setting
13	Current-limiting value during home return	ODPW	%	1 to 300	In accordance with actuator

The factory setting conforms to the standard specification of the actuator.

Increasing this setting will increase the home return torque.

Normally this parameter need not be changed. If the home return should be completed before the correct position depending on the affixing method, load condition or other factors when the actuator is used in a vertical application, the setting value must be increased. Please contact IAI.

### [7] Dynamic Brake (Parameter No.14)

No.	Name	Symbol	Unit	Input Range	Default factory setting
14	Dynamic brake	FSTP	–	0 : Disabled, 1 : Enabled	1

This parameter defines whether the dynamic brake is enabled or disabled while the actuator is at standstill.

Normally it need not be changed.

### [8] SIO Communication Speed (Parameter No.16)

No.	Name	Symbol	Unit	Input Range	Default factory setting
16	SIO communication speed	BRS�	bps	9600 to 230400	38400

Set the SIO baud rate for the startup.

Set an appropriate value in accordance with the communication speed of the host.

One of 9600, 14400, 19200, 28800, 38400, 76800, 115200 and 230400 bps can be selected as the communication speed.

 **Caution:** The baud rate after the PC software is connected will be the rate of PC software. To make effective the value set in the parameter, turn off the power once and on it again.

### [9] Minimum Delay Time for Slave Transmitter Activation (Parameter No.17)

No.	Name	Symbol	Unit	Input Range	Default factory setting
17	Minimum delay time for slave transmitter activation	RTIM	msec	0 to 255	5

In this setting, set the time from receiving the command (received data) during the SIO communication till the response (sent data) is returned to the host side.

[10] Home Position Check Sensor Input Polarity (Parameter No.18)

No.	Name	Symbol	Unit	Input Range	Default factory setting
18	Home position check sensor input polarity	AIOF	-	0 to 2	In accordance with actuator

The home sensor is an option.

Set Value	Description
0	Standard specification (sensor not used)
1	Input is a contact
2	Input is b contact

[11] Overrun Sensor Input Polarity (Parameter No.19)

No.	Name	Symbol	Unit	Input Range	Default factory setting
19	Overrun sensor input polarity	AIOF	-	0 to 2	In accordance with actuator

This parameter is set properly prior to the shipment according to the specification of the actuator.

Set Value	Description
0	Standard specification without sensor
1	Over travel detection sensor input is a contact
2	Over travel detection sensor input is b contact

[12] Creep Sensor Input Polarity (Parameter No.20)

No.	Name	Symbol	Unit	Input Range	Default factory setting
20	Creep sensor input polarity	AIOF	-	0 to 2	In accordance with actuator

Even though the movement speed for most of the actuators at the home return is 20mm/s, there are some actuators with other settings. Refer to the instruction manual of each actuator. Even though the actuator with long stroke requires time to home-return if the power is shut at a point far from the home position, the required time can be improved with using the creep sensor.

The actuator moves at the creep speed (100mm/s or less) until a creep sensor signal is detected, upon which the actuator will decelerate to the home return speed.

Creep sensor is an option for the line axis type.

This parameter is set properly prior to the shipment according to the specification of the actuator.

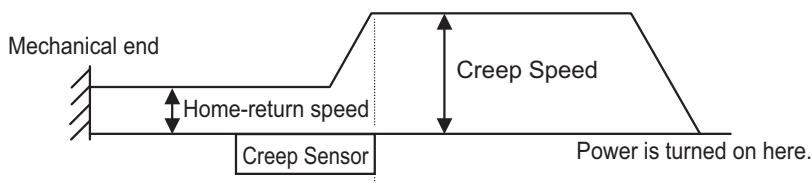

Actuator decelerates when creep sensor signal is detected

Set Value	Description
0	Not to use
1	Input is a contact
2	Input is b contact

## [13] Servo ON Input Disable (Parameter No.21)

No.	Name	Symbol	Unit	Input Range	Default factory setting
21	Servo ON input disable	FPIO	–	0: Enabled, 1: Disabled	0

This parameter defines whether the servo ON input signal is disabled or enabled. When the servo ON input signal is disabled, the servo is turned ON as soon as the controller power is turned ON.

Set this parameter to “1” if servo ON/OFF is not provided by PIO signals.

Set Value	Description
0	Enabled (Use the input signal)
1	Disabled (Does not use the input signal)

## [14] Home Return Offset Level (Parameter No.22)

No.	Name	Symbol	Unit	Input Range	Default factory setting
22	Home return offset level	OFST	mm (deg)	0.00 to 9999.99	In accordance with actuator

The distance from the encoder datum point (Z-phase) to the home position is set up.

In this setting can set the distance from the mechanical end to the home position.

An adjustment is available for the following cases.

- 1) Want to match the actuator home position and the mechanical origin of the system.
- 2) Want to set a new home after reversing the factory-set home direction.
- 3) Want to eliminate a slight deviation from the previous home position generated after replacing the actuator.

### [Adjustment Process]

- 1) Homing execution
- 2) Offset check
- 3) Parameter setting change
- 4) If setting a number close to a multiple of the lead length (including home-return offset value = 0) to the home offset value, there is a possibility to servo lock on Z-phase at absolute reset, thus the coordinates may get shifted for the lead length.

For Absolute Type, do not attempt to set a value near a number that the lead length is multiplied by an integral number.

Have enough margin.

After the setting, repeat home return several times to confirm that the actuator always returns to the same home position.

 **Caution :** If the home return offset has been changed, the soft limit parameters must also be adjusted accordingly.  
In case the there is a necessity of setting a value more than the initial setting, contact IAI.

## [15] Zone 2+, Zone 2– (Parameter No.23, No.24)

[Refer to 7.2 [1]]

## [16] PIO Pattern Selection (Parameter No.25)

No.	Name	Symbol	Unit	Input Range	Default factory setting
25	PIO pattern selection	IOPN	–	0 to 7	0 (Standard Type)

It is not necessary to change from the initial value. (future expansion)

## [17] PIO Jog Velocity (Parameter No.26), PIO Jog Velocity 2 (Parameter No.47)

No.	Name	Symbol	Unit	Input Range	Default factory setting
26	PIO jog velocity	IOJV	mm/s (deg/s)	1 to Actuator's max. velocity <sup>(note1)</sup>	100

It is the velocity setting for when having JOG operation on the PC software.  
Set an appropriate value in Parameter No.26 in accordance with the purpose of use.  
Note 1 The maximum speed is limited to 250mm/s.

## [18] Velocity Loop Proportional Gain (Parameter No.31)

No.	Name	Symbol	Unit	Input Range	Default factory setting
31	Velocity loop proportional gain	VLPG	–	1 to 9999999	In accordance with actuator

This parameter determines the response of the speed control loop. When the set value is increased, the follow-up ability to the velocity command becomes better (the servo-motor rigidity is enhanced). The higher the load inertia becomes, the larger the value should be set. However, excessively increasing the setting will cause overshooting or oscillation, which facilitates producing the vibrations of the mechanical system.

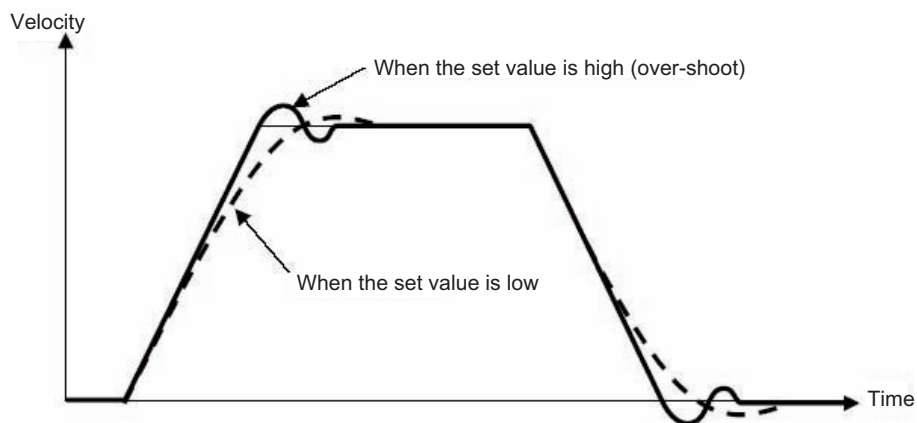

## [19] Velocity Loop Integral Gain (Parameter No.32)

No.	Name	Symbol	Unit	Input Range	Default factory setting
32	Velocity loop integral gain	VLPT	-	1 to 9999999	In accordance with actuator

Any machine produces frictions. This parameter is intended to cope with deviation generated by external causes including frictions. Increasing the setting value improves the reactive force against load change. That is, the servo rigidity increases. However, increasing the parameter value excessively may make the gain too high, which then cause the machine system to be vibrated due to overshoot or shaking.

Tune it to obtain the optimum setting by watching the velocity response.

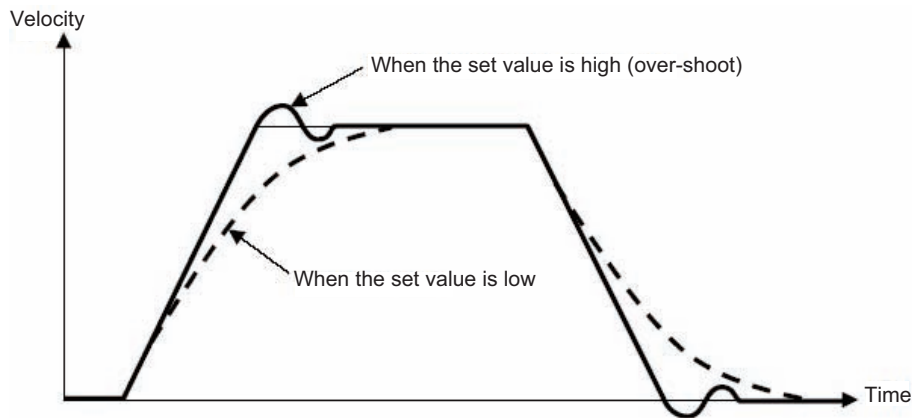

## [20] Torque Filter Time Constant (Parameter No.33)

No.	Name	Symbol	Unit	Input Range	Default factory setting
33	Torque filter time constant	TRQF	-	0 to 2500	In accordance with actuator

This parameter decides the filter time constant for the torque command. When vibrations and/or noises occur due to mechanical resonance during operation, this parameter may be able to suppress the mechanical resonance. This function is effective for torsion resonance of ball screws (several hundreds Hz).

[21] Press Velocity (Parameter No.34)

No.	Name	Symbol	Unit	Input Range	Default factory setting
34	Press velocity	PSHV	mm/s (deg/s)	1 to actuator's max. pressing speed	In accordance with actuator

This is the parameter to set the velocity in pressing operation. The setting is done considering the actuator type when the product is delivered. [Refer to 9.4 List of Specifications of Connectable Actuators] If a change to the setting is required, make sure to have the setting below the maximum pressing velocity of the actuator. Setting it fast may disable to obtain the specified pressing force. Also when setting at a low velocity, take 5mm/s as the minimum.

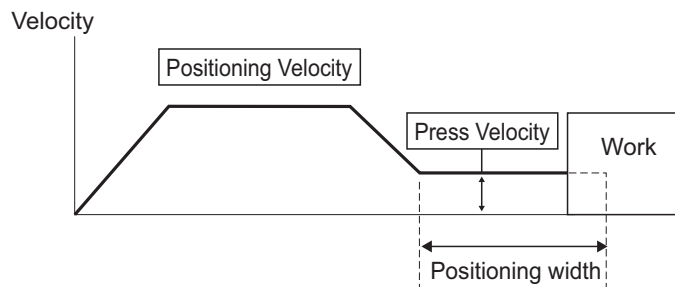

[22] Safety Velocity (Parameter No.35)

No.	Name	Symbol	Unit	Input Range	Default factory setting
35	Safety velocity	SAFV	mm/s (deg/s)	1 to 250 (maximum speed for the actuators with 250 or less)	100

This is the parameter to set the maximum speed of manual operation while the safety velocity selected in the teaching tool. Do not have the setting more than necessary.

[23] Home Return Input Disable (Parameter No.40)

No.	Name	Symbol	Unit	Input Range	Default factory setting
40	Home return input disable	FPIO	-	0: Enabled, 1: Disabled	0

This parameter defines whether the home return input signal is disabled or enabled. Normally this parameter need not be changed.

Set Value	Description
0	Enabled (Use the input signal)
1	Disabled (Does not use the input signal)

## [24] Operating Mode Input Disable (Parameter No.41)

No.	Name	Symbol	Unit	Input Range	Default factory setting
41	Operating mode input disable	FPIO	–	0: Enabled, 1: Disabled	0

This parameter defines whether the operation mode input signal is disabled or enabled. Normally this parameter need not be changed.

Set Value	Description
0	Enabled (Use the input signal)
1	Disabled (Does not use the input signal)

## [25] Enable Function (Parameter No.42)

No.	Name	Symbol	Unit	Input Range	Default factory setting
42	Enable function	FPIO	–	0: Enabled, 1: Disabled	1

Set valid/invalid the deadman switch function if the teaching pendant is equipped with a deadman switch.

Set Value	Description
0	Enabled (Use the function)
1	Disabled (Does not use the function)

## [26] Silent Interval Magnification (Parameter No.45)

No.	Name	Symbol	Unit	Input Range	Default factory setting
45	Silent interval magnification	SIVM	times	0 to 10	0

Use this parameter to set the silent interval (no communication) time by the time taken for communication of 3.5 characters or longer before command data transmission when the controller is operated via serial communication.

This parameter need not be changed when a teaching tool such as PC software is used. If "0" is set, no multiplier is applied.

## [27] PIO Jog Velocity 2 (Parameter No.47)

Refer to Section 7.2 [17] for details.

## [28] PIO Inch Distance, PIO Inch Distance 2 (Parameter No.48, No.49)

No.	Name	Symbol	Unit	Input Range	Default factory setting
48	PIO inch distance	IOID	mm	0.01 to 1.00	0.1
49 <sup>(Note1)</sup>	PIO inch distance 2	IOD2	mm	0.01 to 1.00	0.1

Set the distance for when inching operation is indicated in the PC software. The maximum allowable value is 1mm.

Note 1 Parameter No.49 [PIO inching distance 2] is not used for the controller.



**[29] Current Control width Number (Parameter No.54)**

No.	Name	Symbol	Unit	Input Range	Default factory setting
54	Current control width number	CLPF	–	0 to 15	In accordance with actuator

This parameter is for the manufacturer’s use only to determine the response capability of the current loop control. Therefore, do not change the settings in this parameter. If the parameter is changed carelessly, control safety may be adversely affected and a very dangerous situation may result.

**[30] Pulse Count Direction (Parameter No.62)**

This parameter is used for the feedback pulse.  
[Refer to 5.1.1 Settings]

**[31] Feedback Pulse Output (Parameter No.68)**

This parameter defines whether feedback pulse output is enabled or disabled.  
[Refer to 5.1.1 Settings]

**[32] Feedback Pulse Train (Parameter No.69)**

This parameter defines the output pattern of feedback pulses.  
[Refer to 5.1.1 Settings]

**[33] Feedback Pulse Form Polarity (Parameter No.70)**

Refer to 5.1.1 Output Settings of Feedback Pulse for the details.

[34] Feed Forward Gain (Parameter No.71)

No.	Name	Symbol	Unit	Input Range	Default factory setting
71	Feed forward gain	PLFG	-	0 to 100	0

This parameter defines the level of feed forward gain to be applied to position control. Setting this parameter allows the servo gain to be increased and the response of the position control loop to be improved. This is the parameter to improve the takt time and traceability even more after fine-tuning the settings for [Servo Gain Number (Parameter No.7)], [Velocity Loop Proportional Gain (Parameter No.31)], etc. This can result in shorter positioning time. The gain adjustment of position, speed and current loop in feedback control can directly change the response of the servo control system. Thus, improper adjustment may cause the control system to be unstable and further vibrations and/or noises to occur. On the other hand, since this parameter only changes the speed command value and does not relate with the servo loop, it neither makes the control system unstable nor generate continuous vibrations and/or noises. However, excessive setting may generate vibrations and/or noises until the machine can follow command values in every operation.

In the trapezoidal pattern, adding the value resulting from multiplying the speed command by the [Feed Forward Gain] to the speed command can reduce the delay of speed follow-up and the position deviation.

The feedback control providing control in accordance with the result causes control delay to occur. This conducts the supportive control independent from the control delay.

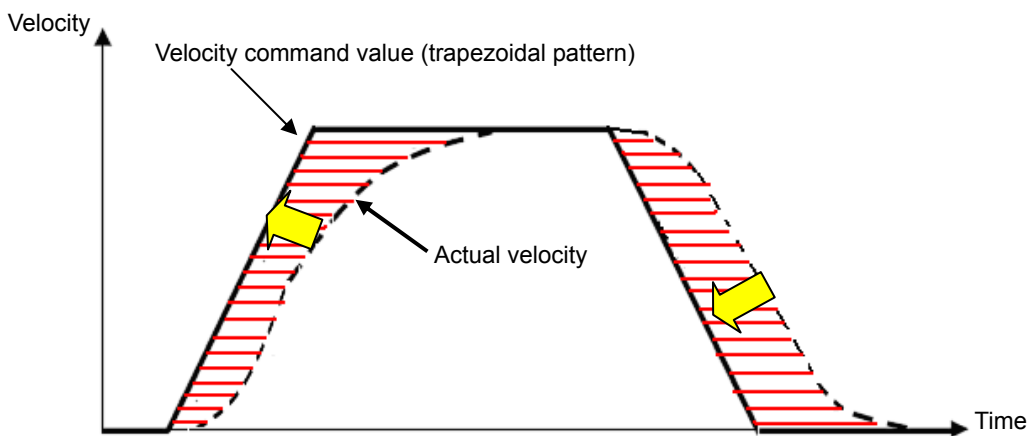

[35] Timer Period for Emergency Stop Relay Fusing Monitor (Parameter No.72)

No.	Name	Symbol	Unit	Input Range	Default factory setting
72	Timer period for emergency stop relay fusing monitor	EMWT	msec	0 to 60000	3000

This parameter defines the timer period in which fusing of the emergency stop relay for cutting off the motor drive power is detected.

If the motor AC power is not cut off after elapse of the timer period set by this parameter following the cutoff of the driver power, the control will recognize that the relay has been fused and generate an alarm.

Normally this parameter need not be changed. When a value between 0 and 9 is set, no fusing is detected.

[36] Encoder Voltage Level (Parameter No.73)

No.	Name	Symbol	Unit	Input Range	Default factory setting
73	Encoder voltage level	EVLV	-	0 to 3	Depending on encoder cable length

To stabilize encoder detection signals, this parameter defines the voltage supplied to the encoder circuit to one of four levels in accordance with the encoder type and the length of the encoder relay cable.

Normally this parameter need not be changed. If you have changed the length of the encoder relay cable after the shipment, the value of the parameter may be changed.

If you wish to change this parameter, always consult us in advance. If the setting is not optimum, it may cause an operation error of the actuator or malfunction of the encoder.

[37] PIO Power Supply Supervision (Parameter No.74)

No.	Name	Symbol	Unit	Input Range	Default factory setting
74	PIO power supply supervision <sup>(Note1)</sup>	FPIO	-	0: Enabled 1: Disabled	0

A power monitor function is provided to prevent incorrect operations, burning of the I/O board and/or breakdown of parts caused by an abnormal voltage of the 24V DC for PIO power supply. This parameter can be disabled in certain situations such as when the controller is operated by a teaching tool without connection of PIO during trail operation for adjustments. Do not forget put it back to "0" (Enabled) before starting the system operation after the test run for the adjustment is finished.

Set Value	Description
0	Enabled
1	Disabled

Note 1 The power monitoring will not be conducted no matter the settings for the Fieldbus types (CC-Link/DeviceNet, etc).

## [38] Electromagnetic Brake Power Monitor (Parameter No.75)

No.	Name	Symbol	Unit	Input Range	Default factory setting
75	Electromagnetic brake power monitor	FSTP	–	0: Disabled 1: Enabled	In accordance with actuator

A power monitor function is provided to prevent actuator malfunction or breakdown of parts caused by an abnormal voltage of the 24V DC brake power supply when an actuator with brake is used.

Normally this parameter need not be changed because it has been set properly prior to the shipment in accordance with the actuator, i.e. whether or not the actuator is equipped with brake.

Set Value	Description
0	Disabled (no brake)
1	Enabled (with brake)

 Caution: If this parameter is set to “Disabled”, no brake control is provided.

## [39] Belt Breaking Sensor Input Polarity (Parameter No.76)

No.	Name	Symbol	Unit	Input Range	Default factory setting
76	Belt breaking sensor input polarity	AIOF	–	0 to 2	In accordance with actuator

Set the sensor input polarity for Alarm Code 0D7 [Belt Break Detection] for High Thrust Type.

Parameter No.		Set Value
76	Not used	0
	Input is a contact	1
	Input is b contact	2

 Caution: Changing the setting of this parameter disables the alarm to be detected.

## [40] Ball Screw Lead Length (Parameter No.77)

No.	Name	Symbol	Unit	Input Range	Default factory setting
77	Ball screw lead length	LEAD	mm	0.01 to 999.99	In accordance with actuator

This parameter set the ball screw lead length.

The factory setting is the value in accordance with the actuator characteristics.

 Caution: If the setting is changed, not only the normal operation with indicated speed, acceleration or amount to move is disabled, but also it may cause a generation of alarm, or malfunction of the unit.

[41] Fieldbus Operation Mode (Parameter No.84)

This parameter is exclusively used for the controller of fieldbus specification.  
Check the relevant Instruction Manual of each field bus.

[42] Fieldbus Node Address (Parameter No.85)

This parameter is exclusively used for the controller of fieldbus specification.  
Check the relevant Instruction Manual of each field bus.

[43] Fieldbus Baud Rate (Parameter No.86)

This parameter is exclusively used for the controller of fieldbus specification.  
Check the relevant Instruction Manual of each field bus.

[44] Network Type (Parameter No.87)

This parameter is exclusively used for the controller of fieldbus specification.  
Check the relevant Instruction Manual of each field bus.

[45] Software Limit Margin (Parameter No.88)

No.	Name	Symbol	Unit	Input Range	Default factory setting
88	Software limit margin	SLMA	mm (deg)	0 to 9999.99	In accordance with actuator

This is the parameter to set the amount of over error detection against the soft limit errors set in Parameters No.3 and No.4.  
It is not necessary to change the setting in normal use.

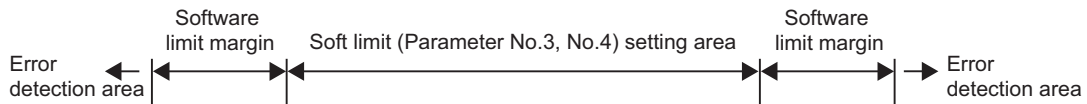

[46] Allowable Time of Exceeding Torque Allowing Continuous Pressing (Parameter No.89)

No.	Name	Symbol	Unit	Input Range	Default factory setting
89	Allowable time of exceeding torque allowing continuous pressing	PSCT	sec	0 to 300	In accordance with actuator

This is the parameter to limit the continuous pressing time when using RCS2-RA13R with the pressing setting of 71% or more.  
When the unit is used beyond this limit, Alarm Code 0C4 “continuous pressing capable torque time over” will be generated to prevent the temperature rise on the motor due to the continuous pressing operation. [Refer to 9.4.2 Specifications and Limitations in Pressing Operation]

Parameter No.89	Description
0	Do not judge
1 to 300sec	Allowable time of continuous pressing (when pressing setting of 71% or more is used in RCS2-RA13R)

**[47] Fieldbus I/O Format (Parameter No.90)**

This parameter is exclusively used for the controller of field bus specification.  
Check the relevant Instruction Manual of each field bus.

**[48] Force Gain (Parameter No.94)**

No.	Name	Symbol	Unit	Input Range	Default factory setting
94	Pressing operation using force sensor gain	FRCG	-	100 to 999999	In accordance with actuator

This parameter defines the gain for pressing operation using force sensor.  
Adjust it considering the stiffness of the pressed object. When changing the setting, increase or decrease gradually referring to the following table.  
The relation among the rigidity of pressing target, the response of pressing operation using force sensor system and pressing operation using force sensor gain differs depending on the actuator, and is as shown in the table below.

**RA13R, RA10R**

	Rigidity of pressing target					
	Hard ← Rigidity → Soft					
Responsiveness of Control System High ← Response → Low	1050	2100	4200	8400	16800	33600
	1200	2400	4800	9600	19200	38400
	1350	2700	5400	10800	21600	43200
	1500	3000	6000	12000	24000	48000
	1650	3300	6600	13200	26400	52800
	1800	3600	7200	14400	28800	57600
	1950	3900	7800	15600	31200	62400

**RA8R**

	Rigidity of pressing target					
	Hard ← Rigidity → Soft					
Responsiveness of Control System High ← Response → Low	2100	4200	8400	16800	33600	67200
	2400	4800	9600	19200	38400	76800
	2700	5400	10800	21600	43200	86400
	3000	6000	12000	24000	48000	96000
	3300	6600	13200	26400	52800	105600
	3600	7200	14400	28800	57600	115200
	3900	7800	15600	31200	62400	124800

RA7R

		Rigidity of pressing target Hard ← Rigidity → Soft					
Responsiveness of Control System High ← Response → Low		3500	7000	14000	28000	56000	112000
		4000	8000	16000	32000	64000	128000
		4500	9000	18000	36000	72000	144000
		5000	10000	20000	40000	80000	160000
		5500	11000	22000	44000	88000	176000
		6000	12000	24000	48000	96000	192000
		6500	13000	26000	52000	104000	208000

RA6R

		Rigidity of pressing target Hard ← Rigidity → Soft					
Responsiveness of Control System High ← Response → Low		7000	14000	28000	56000	112000	224000
		8000	16000	32000	64000	128000	256000
		9000	18000	36000	72000	144000	288000
		10000	20000	40000	80000	160000	320000
		11000	22000	44000	88000	176000	352000
		12000	24000	48000	96000	192000	384000
		13000	26000	52000	104000	208000	416000

RA4R

		Rigidity of pressing target Hard ← Rigidity → Soft					
Responsiveness of Control System High ← Response → Low		10500	21000	42000	84000	168000	336000
		12000	24000	48000	96000	192000	384000
		13500	27000	54000	108000	216000	432000
		15000	30000	60000	120000	240000	480000
		16500	33000	66000	132000	264000	528000
		18000	36000	72000	144000	288000	576000
		19500	39000	78000	156000	312000	624000

RA15R, RA20R

		Rigidity of pressing target Hard ← Rigidity → Soft					
Responsiveness of Control System High ← Response → Low		525	1050	2100	4200	8400	16800
		600	1200	2400	4800	9600	19200
		625	1350	2700	5400	10800	21600
		750	1500	3000	6000	12000	24000
		825	1650	3300	6600	13200	26400
		900	1800	3600	7200	14400	28800
		975	1950	3900	7800	15600	31200

## [49] Force Judgment Margin + / - (Parameter No.95, No.96)

No.	Name	Symbol	Unit	Input Range	Default factory setting
95	Force judgment margin +	FJMM	%	1 to Maximum Pressing Force	In accordance with actuator
96	Force judgment margin -	FJML	%	1 to Maximum Pressing Force	In accordance with actuator

Set the load range to judge the pressing operation.

The value input in the press program setting window is to be registered. [Refer to chapter 3 Operation]

## [50] Calendar Function (Parameter No.111)

No.	Name	Symbol	Unit	Input Range	Default factory setting
111	Calendar function	FRTC	-	0: Does not use the calendar timer 1: Use the calendar timer	1

This parameter defines whether the calendar function (RTC) is used or not.

Set the current time with using a teaching tool when the calendar function is used.

[Refer to the instruction manual of the teaching tool for the details.]

In use of RTC, the alarm occurrence time in the alarm list is the time at which an alarm has occurred.

If RTC is not used, the time of alarm issuance shown in the alarm list counts the time passed since the power is supplied to the controller counted as 0 second.

The time data retainable duration with no power supply to the controller is approximately 10 days.

## [51] Monitoring Frequency (Parameter No.113)

No.	Name	Symbol	Unit	Input Range	Default factory setting
113	Monitoring Frequency	FMNT	msec	1 to 1000	1

Set the time cycle (sampling frequency) to gather data when Monitoring Mode is selected.

Setting a big number to this parameter will make the time cycle for data gathering longer.

It is set to 1 msec. in the initial setting. Setting is available up to 1000 msec. in the 1 msec. unit.

1 msec. Cycle Setting		1000 msec. Cycle Setting	
In 4CH-30000 Record Mode:	30 sec. max.	In 4CH-300000 Record Mode:	30000 sec. max. (500 min.)
In 4CH-15000 Record Mode:	15 sec. max.	In 8CH-150000 Record Mode:	15000 sec. max. (250 min.)
In 2CH-60000 Record Mode:	60 sec. max.	In 2CH-600000 Record Mode:	60000 sec. max. (1000 min.)

## [52] Electrical Gear (Feedback Pulse) (Parameter No.115, No.116)

No.	Name	Symbol	Unit	Input Range	Default factory setting
115	Electronic gear numerator (Feedback pulse)	FNUM	-	1 to 99999999	1
116	Electronic gear denominator (Feedback pulse)	FDEN	-	1 to 99999999	1

The input range is from 1 to 4096 if the controller version is earlier than V0005.

Refer to 5.1.1 Output Settings of Feedback Pulse for the details.



### [53] Automatic Loadcell Calibration at Start (Parameter No.117)

No.	Name	Symbol	Unit	Input Range	Default factory setting
117	Automatic loadcell calibration at start	FFRC	–	0: Does not perform 1: Perform	1

This parameter is exclusively used for pressing operation using force sensor.

Set Value	Description
0	Does not provide loadcell calibration automatically.
1	Provides loadcell calibration automatically. (initial value)

[Refer to 3.3.2 Operation Ready and Auxiliary Signals]

### [54] Loadcell Calibration Time (Parameter No.119)

No.	Name	Symbol	Unit	Input Range	Default factory setting
119	Loadcell calibration time	CLBT	msec	1 to 9999	10

This parameter is exclusively used for pressing operation using force sensor. This parameter defines the adjustment data acquisition time in loadcell calibration. Normally, setting change is not necessary.

[Refer to chapter 3 Operation]

### [55] Servo Gain Number 1 (Parameter No.120)

This parameter determines the response of the position control loop.

[Refer to description of Parameter No.7.]

### [56] Feed Forward Gain 1 (Parameter No.121)

This parameter defines the feed forward gain of the position control system.

[Refer to description of Parameter No.71.]

### [57] Velocity Loop Proportional Gain 1 (Parameter No.122)

This parameter determines the response of the speed control loop.

[Refer to description of Parameter No.31.]

### [58] Velocity Loop Integral Gain 1 (Parameter No.123)

This parameter determines the response of the speed control loop.

[Refer to description of Parameter No.32.]

### [59] Torque Filter Time Constant 1 (Parameter No.124)

This parameter decides the filter time constant for the torque command.

[Refer to description of Parameter No.33.]

### [60] Current Control width Number 1 (Parameter No.125)

This parameter defines the control width of the current control system.

[Refer to description of Parameter No.54.]

### [61] Servo Gain Number 2 (Parameter No.126)

This parameter determines the response of the position control loop.

[Refer to description of Parameter No.7.]

- [62] Feed Forward Gain 2 (Parameter No.127)  
This parameter defines the feed forward gain of the position control system.  
[Refer to description of Parameter No.71.]
- [63] Speed Loop Proportional Gain 2 (Parameter No.128)  
This parameter determines the response of the speed control loop.  
[Refer to description of Parameter No.31.]
- [64] Speed Loop Integral Gain 2 (Parameter No.129)  
This parameter determines the response of the speed control loop.  
[Refer to description of Parameter No.32.]
- [65] Torque Filter Time Constant 2 (Parameter No.130)  
This parameter decides the filter time constant for the torque command.  
[Refer to description of Parameter No.33.]
- [66] Current Control width Number 2 (Parameter No.131)  
This parameter defines the control width of the current control system.  
[Refer to description of Parameter No.54.]
- [67] Servo Gain Number 3 (Parameter No.132)  
This parameter determines the response of the position control loop.  
[Refer to description of Parameter No.7.]
- [68] Feed forward gain 3 (Parameter No.133)  
This parameter defines the feed forward gain of the position control system.  
[Refer to description of Parameter No.71.]
- [69] Velocity Loop Proportional Gain 3 (Parameter No.134)  
This parameter determines the response of the speed control loop.  
[Refer to description of Parameter No.31.]
- [70] Velocity Loop Integral Gain 3 (Parameter No.135)  
This parameter determines the response of the speed control loop.  
[Refer to description of Parameter No.32.]
- [71] Torque Filter Time Constant 3 (Parameter No.136)  
This parameter decides the filter time constant for the torque command.  
[Refer to description of Parameter No.33.]
- [72] Current Control width Number 3 (Parameter No.137)  
This parameter defines the control width of the current control system.  
[Refer to description of Parameter No.54.]

[73] Servo Gain Switchover Time Constant (Parameter No.138)

No.	Name	Symbol	Unit	Input Range	Default factory setting
138	Servo gain switchover time constant	GCFT	ms	10 to 2000	10

When a switchover of the servo gain set is commanded in the detail setting of press program, the switchover process is completed after time more than 3 times of the time spent in the setting of this parameter is passed since the operation of the commanded position number has started.

**⚠ Caution:** A time constant being rather short may cause the servo gain to change rapidly to have the operation of the actuator unstable.

[74] Home Preset Value (Parameter No.139)

No.	Name	Symbol	Unit	Input Range	Default factory setting
139	Home preset value	PRST	mm	-9999.99 to 9999.99	In accordance with actuator

For the actuator of absolute specification, set this parameter so that (home return offset + value of this parameter) is within the range between 0 and the ball screw lead. (as it is necessary to register the Z-phase nearest to the mechanical end as the datum)  
 The value should be an integer multiple of  $\pm$ ball screw lead length including 0.00.  
 (If the home return offset is within the range between 0 and ball screw lead length, the value of this parameter is 0.00.)  
 Also, when a value other than 0.00 is set in this parameter, home-return complete position cannot be 0.00, and it gets to the position of home position + this parameter.

**⚠ Caution:** If the above condition is not satisfied, the home position at restart after home return may shift by an integer multiple of the ball screw lead.

For the actuator of incremental specification, always set this parameter to 0.00.

<Setting example 1>

With ball screw lead length 4mm and home return offset level 10mm, set this parameter to -8mm.

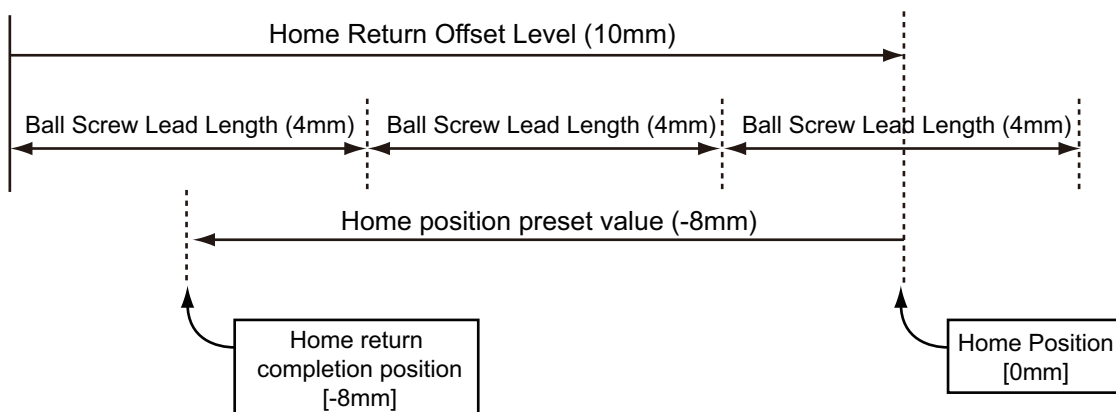

[75] IP Address (Parameter No.140)

No.	Name	Symbol	Unit	Input Range	Default factory setting
140	IP address	IPAD	-	0.0.0.0 to 255.255.255.255	192.168.0.1

It is the parameter dedicated for Fieldbus (EtherNet/IP).  
 [For details, refer to Fieldbus Instruction Manual.]

[76] Subnet Mask (Parameter No.141)

No.	Name	Symbol	Unit	Input Range	Default factory setting
141	Subnet mask	SNMK	-	0.0.0.0 to 255.255.255.255	255.255.255.0

It is the parameter dedicated for Fieldbus (EtherNet/IP).  
 [For details, refer to Fieldbus Instruction Manual.]

[77] Default Gateway (Parameter No.142)

No.	Name	Symbol	Unit	Input Range	Default factory setting
142	Default gateway	DFGW	-	0.0.0.0 to 255.255.255.255	0.0.0.0

It is the parameter dedicated for Fieldbus (EtherNet/IP).  
 [For details, refer to Fieldbus Instruction Manual.]

[78] Overload Level Ratio (Parameter No. 143)

No.	Name	Symbol	Unit	Input Range	Default factory setting
143	Overload level ratio	OLWL	%	50 to 100	100

With the estimated motor risen temperature to generate overload alarm set as 100%, the overload warning (message level: \*ALML Signal is OFF) alarm is output when the motor temperature has exceeded the ratio set in this parameter. Judgment will not be executed if set to 100.

[Applied: prevention function]

By setting this parameter, warning output notifies you before the equipment stops by error in case that the motor temperature rises due to load condition change caused by dry-up of grease or wear-out of components. Warning output (ALML Signal) can be conducted with PIO<sup>+</sup> or fieldbus.

\* PIO output, parameter No.151 set to 0.

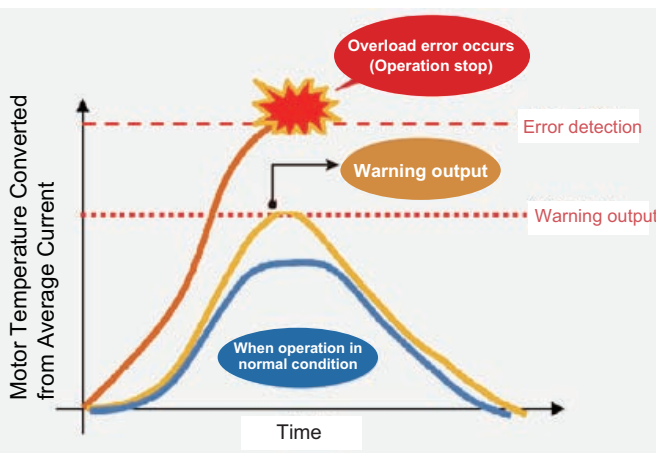

The current applied to the motor increases because of sliding resistance increase due to lack of maintenance of guide and ball screw or excess load applied on the motor.  
**As a result, overload error occurs and the device stops the operation.**

The current applied to the motor increases gradually as the sliding resistance gets higher without supplying grease on guide and ball screw. Warning will be generated if the current reaches the threshold that you set.  
**At this time, the device will not stop, but have inspection and maintenance work held and remove the cause immediately.**

Normal Operation Range

**[79] Total Movement Count Target Value (Parameter No.147)**

No.	Name	Symbol	Unit	Input Range	Default factory setting
147	Total movement count target value	TMCT	Times	0 to 999999999	0 (Disabled)

An alarm is generated when the total movement count exceeds the value set to this parameter.  
The judgment would not be made if the value is set to 0.

**[80] Total Operated Distance Target Value (Parameter No.148)**

No.	Name	Symbol	Unit	Input Range	Default factory setting
148	Total operated distance target value	ODOT	m	0 to 999999999	0 (Disabled)

An alarm is generated when the total operation distance exceeds the value set to this parameter.  
The judgment would not be made if the value is set to 0.

**[81] Light Error Alarm Output Select (Parameter No.151)**

No.	Name	Symbol	Unit	Input Range	Default factory setting
151	Light error alarm output select	FSTP	-	Refer to table below	0

\*ALML Signal is output following the output conditions below depending on the settings.

The value set in No. 151	ALML Signal Output Conditions (when either of the conditions below is occurred)
0	1) Output of battery voltage drop warning 2) Driver overload warning (Message-level alarm 048) 3) Number of FAN revolution has dropped. (Message-level alarm 04C)
1	1) Output of battery voltage drop warning 2) Message-level alarm

**[82] Nominal Rigidity (Parameter No.163)**

No.	Name	Symbol	Unit	Input Range	Default factory setting
163	Nominal rigidity	FCNS	N/mm	1 to 99999	In accordance with actuator

It is the value of rigidity for each actuator.  
Do not change the setting from the initial setting.

**[83] Force Control Band (Parameter No.164)**

No.	Name	Symbol	Unit	Input Range	Default factory setting
164	Force control band	FCBW	rad/s	1 to 99	10

Setting is established for the band used as the force control.  
Do not change the setting from the initial setting.

## [84] Delay Time After Shutdown Release (Parameter No.165)

No.	Name	Symbol	Unit	Input Range	Default factory setting
165	Delay time after shutdown release	SDDT	ms	0 to 10000	0

It is used in purpose to distribute the in-rush current. It is used to set the delay time from the driving power supply to shutdown cancellation. It is available to scatter the peak load by having the time setting separately on each controller.

e.g.) When building up a drive cutoff circuit externally

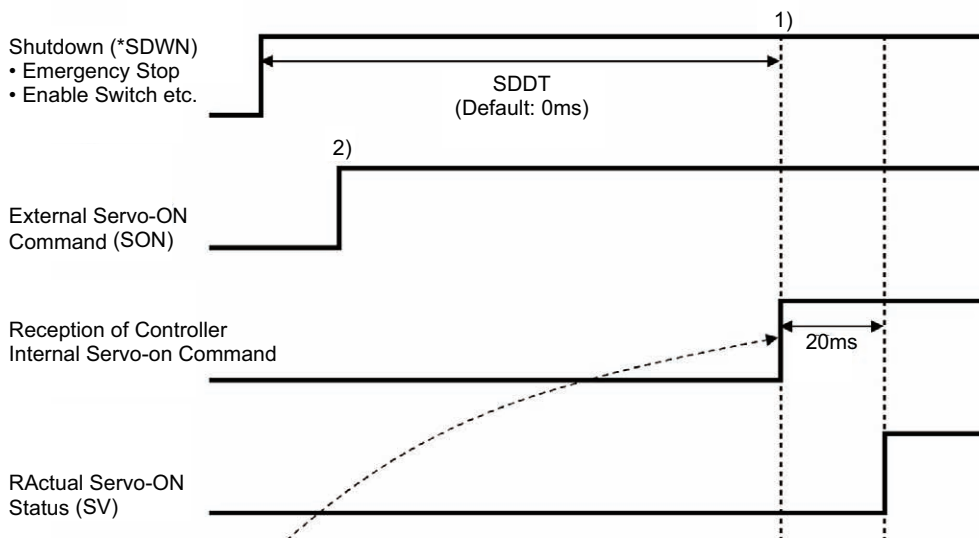

If the on-edge 2) of external servo-ON command came after the point of passing SDDT time 1), the condition becomes reception of controller internal servo-ON command at the point of 2).

## [85] Selection of SIO2 Baud Rate (Parameter No.169)

No.	Name	Symbol	Unit	Input Range	Default factory setting
169	Selection of baud rate SIO2	BRSL	bps	9600 to 230400	38400

Set the baud rate in the startup SIO2 baud rate.

Set an appropriate value in accordance with the communication speed of the host.

One of 9600, 14400, 19200, 28800, 38400, 76800, 115200 and 230400 bps can be selected as the communication speed.

**⚠ Caution:** The baud rate after the PC software is connected will be the rate of PC software. To make effective the value set in the parameter, turn off the power once and on it again.

[86] SIO2 Minimum Delay Time for Slave Transmitter Activation (Parameter No.170)

No.	Name	Symbol	Unit	Input Range	Default factory setting
170	Minimum delay time for slave transmitter activation	RTM2	msec	0 to 255	5

In this setting, set the time from receiving the command (received data) during the SIO2 communication till the response (sent data) is returned to the host side.

[87] SIO2 Silent Interval Magnification (Parameter No.171)

No.	Name	Symbol	Unit	Input Range	Default factory setting
171	SIO2 silent interval magnification	SIM2	Time	0 to 10	0

Use this parameter to set the silent interval (no communication) time by the time taken for communication of 3.5 characters or longer before command data transmission when the controller is operated via serial communication.

This parameter need not be changed when a teaching tool such as PC software is used. If "0" is set, no multiplier is applied.

[88] SIO2 Slave Address (Parameter No.172)

No.	Name	Symbol	Unit	Input Range	Default factory setting
172	SIO2 slave address	MSA2	-	0 to 16	0

Set the slave address when SIO2 communication.

Set to 0, and it becomes the same as the standard SIO setting (set at the unit number setting switch on the front panel of the controller).

(Note) Make sure to establish the setting to avoid duplication of the unit number to a device connected to SIO2.

[89] Force Control Transition Threshold (Parameter No.173)

No.	Name	Symbol	Unit	Input Range	Default factory setting
173	Force control transition threshold	FCTH	%	10 to 90	In accordance with actuator

The threshold to transit from the ordinary movement to the force control movement considering loadcell load data is set. Set in this parameter the ratio to the target load, maximum load or target incremental load setting in the pressurizing stage setting.

Conduct tuning with increase and decrease in 5 to 10 units.

[90] Force Gains 1 to 3 (Parameter No.174 to No.176)

Refer to 7.2 [48].

## [91] Load Detection Filter (Parameter No.177)

No.	Name	Symbol	Unit	Input Range	Default factory setting
177	Load detection filter	LDFT	ms	1 to 10	3

When reading the next load data from the loadcell, it is determined as the specified load detection if the conditions are satisfied for the time set in this parameter.

- 1) Approach max. load
- 2) Probing complete load
- 3) Pressurizing maximum load in pressurizing operation and in stop
- 4) Pressurizing complete load in pressurizing operation
- 5) Pressurizing target load in pressurizing operation
- 6) Decompressing complete load

## [92] Return Operation Initial Value at Press Program Alarm (Parameter No.178)

No.	Name	Symbol	Unit	Input Range	Default factory setting
178	Return operation initial value at press program alarm	FPRS	-	0 to 1	0

Establish the setting for operation when a press program alarm is occurred.

Setting value	Description
0	Return to the program home position and turn the servo OFF
1	Stop at the point of alarm generation and turn the servo OFF

## [93] Return Operation Initial Value at Press Program Compulsory Complete (Parameter No.179)

No.	Name	Symbol	Unit	Input Range	Default factory setting
179	Return operation initial value at press program compulsory complete	FPRS	-	0 to 1	0

Establish the setting for operation when a press program is finished compulsorily.

Setting value	Description
0	Return to the program home position and turn the servo OFF
1	Stop at the point of alarm generation and turn the servo OFF

## [94] DAC Output (Parameter No.180)

No.	Name	Symbol	Unit	Input Range	Default factory setting
180	DAC output	FPIO	-	0 to 1	1

Set if outputting in analog the load data from the multi-function connector.

[Refer to 5.2 Analog Output of Load Data]

Setting value	Description
0	Analog output enabled
1	Analog output disabled



[95] Regenerative Control Select (Parameter No.184)

No.	Name	Symbol	Unit	Input Range	Default factory setting
184	Regenerative Control Select	RDSL	-	1 to 2	1

Confirm the motor output of the actuator to be connected and set it.

Setting value	Motor output
1	~ 750W
2	3000W ~

### 7.3 Servo Adjustment

The parameters are preset at the factory before shipment so that the actuator operates stably within the rated (maximum) transportable weight. However, the preset setting cannot always be the optimum load condition in the actual use. In such cases, servo adjustment may be required. This section describes the basic servo adjustment method.

**⚠ Caution:** Rapid and excessive settings are dangerous. They may damage devices including the actuator or injure people. Take sufficient note on the setting. Record settings during servo adjustment so that prior settings can always be recovered. When a problem arises and the solution cannot be found, please contact IAI.

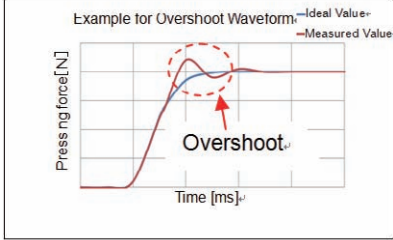
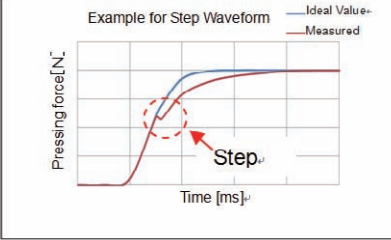
No.	Situation that requires adjustment	How to Adjust
1	Overshooting or step occurs at pressurizing (check the feedback value of the loadcell in the analog output or PC software)	<div style="display: flex; justify-content: space-around;">   </div> <ol style="list-style-type: none"> <li>1) Try to decrease the pressurizing speed.</li> <li>2) Detail of Parameters to section 7.2 Adjust &gt; register the force gain (Parameter No. 94, 174 to 176) by referring to Section 7.2 [48]. Set the gain set number that makes the registered force gain valid in the detailed setting of the press program. [Refer to chapter 3 Press Program Detailed Settings]</li> <li>3) If the condition would not improve with the tuning above, adjust Parameter No. 173 Force Control Threshold with following conditions. Conduct tuning with increase and decrease in 5 to 10 units. <ul style="list-style-type: none"> <li>• When an overshoot is occurred, decrease the force control transition threshold.</li> <li>• When the stiffness of the work piece is low, increase the force control transition threshold.</li> </ul> </li> </ol>
2	Vibration is generated at acceleration/deceleration	<ul style="list-style-type: none"> <li>• The cause of the problem is excessive "acceleration/deceleration setting" or vulnerable structure of the unit on which the actuator is installed. If possible, reinforce the unit itself, first.</li> <li>• Decrease the values of "acceleration/deceleration setting".</li> <li>• Decrease the number of Parameter No.7 "Servo gain number". If the Parameter No.7 "Servo gain number" is too low, it takes long time to finish the positioning.</li> </ul>
3	Speed is uneven during the movement	<ul style="list-style-type: none"> <li>• Increase the value of Parameter No.31 "Speed loop proportional gain". By setting a larger value, the follow-up ability to the speed command becomes better. Setting too large value makes the mechanical components easy to vibrate. As a reference for the setting, increase the value little by little by 20% from the initial setting.</li> </ul>

No.	Situation that requires adjustment	How to Adjust
4	<p>Abnormal noise is generated. Especially, when stopped state and operation in low speed (less than 50mm/sec), comparatively high noise is generated.</p>	<ul style="list-style-type: none"> <li>• Input the "Torque Filter Time Constant". Try to increase by 50 as a reference for the setting. If the setting is too large, it may cause a loss of control system stability and lead the generation of vibration.</li> </ul> <p>[Important] Prior to Adjustment: This phenomenon is likely to occur when the stiffness of the mechanical components is not sufficient. The actuator itself may also resonate if its stroke is over 600mm or it is belt-driven type. Before having an adjustment, check if:</p> <ol style="list-style-type: none"> <li>1) The value for Parameter No.7 "Servo gain number", Parameter No.31 "Speed loop proportional gain", or Parameter No.32 "Speed loop integral gain" are excessive.</li> <li>2) The stiffness of the load is sufficient as much as possible, or the attachments are not loosened.</li> <li>3) The actuator unit is mounted securely with a proper torque.</li> <li>4) There is no waviness on the actuator mounting surface.</li> </ol>
5	<p>Large load inertia makes response of actuator low at start and stop.</p>	<ul style="list-style-type: none"> <li>• Set parameter No.71 "Feed forward gain". Select a value in the range from 10 to 50 roughly. The larger the setting value is, the smaller the deviation is. Then the response is improved. Setting a large value may cause vibrations and/or noises to occur.</li> </ul> <p>Set the feed forward gain in order to improve the response of the actuator further after adjusting Parameter No.7 "Servo gain number" and Parameter No.31 "Speed loop proportional gain".</p>

## Chapter 8 Troubleshooting

### 8.1 Action Taken upon Occurrence of Problem

Upon occurrence of a problem, take an appropriate action according to the procedure below in order to ensure quick recovery and prevent recurrence of the problem.

- 1) Check the status indicator LEDs on the controller.

LED	Indication	Status
PWR	Green Light is turned ON.	System ready (normal CPU operation)
	OFF	Power OFF
SV	Green Light is turned ON.	Servo ON (operation available)
	Flashing in Green	Automatic servo is OFF
	OFF	Servo OFF
ALM	Orange Light is turned ON.	Alarm being generated (operation release or cold start level alarm)
EMG	Red Light is turned ON.	Emergency stop (regardless of alarms)

- 2) Check whether an alarm occurs on the host controller (PLC, etc.).
- 3) Check the voltage of the main power supply.
- 4) Check the voltage of power supply for the PIO.
- 5) Check the voltage of the power supply for brake (For the actuator with the brake).
- 6) Alarm Check <sup>(Note 1)</sup>  
Check the alarm code on the teaching tool such as PC software.
- 7) Check the connectors for disconnection or connection error.
- 8) Check the cables for connection error, disconnection or pinching.  
Before performing a continuity check, turn off the power (to prevent electric shocks) and disconnect the cables of measuring instruments (to prevent accidental power connection due to sneak current path).
- 9) Check the I/O signals.  
Using the host controller (PLC, etc.) or a teaching tool such as PC software, check the presence of inconsistency in I/O signal conditions.
- 10) Check the noise elimination measures (grounding, installation of surge killer, etc.).
- 11) Check the events leading to the occurrence of problem <sup>(Note 1)</sup>, as well as the operating condition at the time of occurrence.
- 12) Analyze the cause.
- 13) Treatment

Note1: If parameter No. 111 Selection of using calendar function is set to "1" (use), it is possible to know the date and time at which the alarm occurred. Set the date and time from the teaching tool such as PC software at the first power-on of the controller. The date and time data set once is retained for about 10 days if the power supply of the controller is OFF. Unless the setting is conducted or the clock data is lost, the clock shows 00/01/01 00:00:00 when the power is turned ON. Even if the date and time data is lost, the generated error code is retained. Alarms subject to this function only include those in 8.4 Alarm but do not include errors in the teaching tool such as PC software.

**!** Notice:  
In troubleshooting, exclude normal portions from suspicious targets to narrow down the causes. Check 1) to 11) described above before contacting us.

## 8.2 Fault Diagnosis

This section describes faults largely divided into two types as follows:

- (1) Impossible operation of controller
- (2) Generation of noise and/or vibration

### 8.2.1 Impossible Operation of Controller

Situation	Possible cause	Check/Treatment
At power-on, PWR on the status indicator LEDs does not go on.	Proper power is not supplied.	Check the voltage. If the PWR LED does not go on despite normal power voltage and correct wiring, Please contact IAI. [Refer to chapter 2 Wiring]
EMG on the status indicator LEDs lights.	During emergency-stop. 1) Was the emergency-stop switch. 2) The emergency stop release circuit is OFF to make the connection between EMG+ and EMG- of the system I/O connector open. 3) EMG+/- of the system I/O connector are not connected.	1) Release the emergency stop switch. 2) Check the emergency stop circuit. 3) Check the wiring of system I/O. [Refer to chapter 2 Wiring]
ALM in the status display LEDs turns on when the power is supplied.	Occurrence of alarm.	Check the error code with the teaching tool being connected and remove the cause by referring the alarm list. [Refer to 8.4 Alarm List.]
The host controller (PLC) sends servo ON signal to the controller, but SV LED does not go ON.	PIO signal communication is disabled. 1) 24V DC power for PIO is not supplied. 2) Poor contact of flat cable 3) The operation mode setting switch on the front panel is on "MANU" side. 4) The +/- pins of 24V DC power for PIO are connected inversely.	1) Check the PIO power voltage. If a single power supply is connected with large load, the power supply voltage may drop or the output may be shut down depending on power units. 2) Are the PIO cable connectors inserted to the mating connectors securely? Check the input signals on the I/O monitor of the teaching tool such as PC software.
The host controller (PLC) cannot control PIO (24V DC I/O).		<div style="border: 1px solid black; padding: 5px; margin-bottom: 5px;"> <p><b>⚠ Caution</b> In I/O cable conduction check, do not widen female pins of the connectors. Failure to follow this may cause poor contact.</p> </div> 3) Reverse connection of the PIO power supply does not affect the input circuit but makes the output circuit faulty. Check if the I/O of the host controller (PLC) operates normally.

### 8.2.2 Generation of Noise and/or Vibration

Situation	Possible cause	Check/Treatment
Generation of noise and/or vibration from actuator itself	Noise and vibration are generated by many causes including the status of load, the installation of the actuator, and the rigidity of the unit on which the actuator is installed.	Servo adjustment may improve the situation. [Refer to 7.3 Servo Adjustment.]

### 8.3 Alarm Level

The alarms are classified to 3 types of levels by the content of the error.

Alarm level	ALM lamp	*ALM signal	Status when an error occurred	Cancellation method
Message	OFF	No output	No stop	Alarm from teaching tool such as PC software [Refer to Instruction Manual of each tool for details.]
Operation release	ON	Output	Servo OFF after deceleration to stop	Reset the alarm by the teaching tool.
Operation release (program alarm)			Return to the program home position and turn the servo OFF, or stop at the point and turn the servo OFF	
Cold start	OFF	Output	Servo OFF after deceleration to stop	Alarm from teaching tool such as PC software [Refer to Instruction Manual of each tool for details.]

 **Caution:** Reset each alarm after identifying and removing the cause.  
 If the cause of the alarm cannot be removed or when the alarm cannot be reset after removing the cause, please contact IAI.  
 If the same error occurs again after resetting the alarm, it means that the cause of the alarm has not been removed.

## 8.4 Alarm List

### 8.4.1 Controller Alarm (Excluding Program Alarm)

Alarm Code	Alarm Level	Alarm Name	Cause/Treatment
02E	Message	Calendar function related command in calendar function invalid status	<p>Cause : An attempt was made to use the calendar in the state where the RTC (calendar) function was made ineffective.</p> <p>Treatment : Set parameter No.111 (Selection of use of calendar function) to "1" ("0": no use).</p>
048		Driver overload alarm	<p>Cause : The load current exceeded the value set in Parameter No.143 "Overload Level Ratio". This alarm is kept alarm condition until reset is made. This alarm turns ON when the load current exceeds the setting from a value below the setting.</p> <p>Treatment : Lower the setting of acceleration/deceleration. Also, increase the frequency of pause.</p>
04C		Drop in number of FAN revolution	<p>Cause : The number of the FAN revolution has dropped to the warning level.</p> <p>Treatment : Degradation of the fan can be considered. Replace the FAN.</p>
04D		Excess FAN total operational duration	<p>Cause : The total operation duration of the FAN has exceeded the reference timing for replacement. This alarm is not purposed to indicate an error.</p> <p>Treatment : Utilize this alarm as a reference for the timing to replace the FAN.</p>
04E		Exceeded movement count target value	<p>Cause : The total number of the operation times exceeded the value set in Parameter No.147 "Total Movement Count Threshold".</p>
04F		Exceeded operated distance target value	<p>Cause : The total number of the operation distance exceeded the value set in Parameter No.148 "Total Operated Distance Threshold".</p>
069		Detection of realtime clock oscillation stop	<p>Cause : The calendar function is stopped and the current time data is lost.</p> <p>Treatment : Set the time again. [Refer to the Instruction Manual of RC PC software.] (Note) This error is not registered in the alarm list.</p>
06A		Realtime clock access error	<p>Cause : The calendar function is not working properly because of noise or malfunction of consisting parts.</p> <p>Treatment : 1) Take proper measures against noise. 2) When the calendar function is not used, set parameter No.111 "Calendar function" to "0". 3) If the operation is not improved in use of the calendar function in spite of measures against noise, Please contact IAI.</p>
06B		Maintenance information data error	<p>Cause : The maintenance information (total movement count, total operated distance) is lost.</p> <p>Treatment : Please contact IAI.</p>

Alarm Code	Alarm Level	Alarm Name	Cause/Treatment																
080	Operation release	Move command in servo OFF	<p>Cause : A move command was issued when the servo is OFF.</p> <p>Treatment : Issue a movement command after confirming the servo is ON (servo ON signal (SV) or position complete signal (PEND) is ON).</p>																
083		Position command in incomplete home return	<p>Cause : An absolute position command was issued by numerical specification before home return was completed (direct command from Fieldbus).</p> <p>Treatment : Issue a numeric specification after performing home return operation and confirming the complete signal (HEND).</p>																
084		Numerical command in incomplete home return	<p>Cause : A move command was issued when home return was still in progress.</p> <p>Treatment : Issue a movement command after performing home return operation and confirming the complete signal (HEND).</p>																
087		Moving command during loadcell calibration	<p>Cause : A move command was issued during loadcell calibration.</p> <p>Treatment : After confirming the loadcell calibration is completed with the calibration complete (CEND) signal, and confirming CLBR Signal is turned OFF, perform the movement command.</p>																
090		Software reset during servo ON	<p>Cause : A software reset command was issued when the servo was ON.</p> <p>Treatment : Issue a software reset command after confirming that the servo is OFF (SV signal is 0).</p>																
094		Press Program alarm detected	<p>Cause : It shows there was an alarm issued during press program execution</p> <p>Treatment : Refer to the press program alarm list below to have an appropriate treatment.[Refer to 8.4.2 Program Alarm]</p>																
0A1	Cold start	Parameter data error	<p>Cause : The data input range in the parameter area is not appropriate. This error occurs when the magnitude relationship is apparently inappropriate such as when 300mm was incorrectly input as the value of the soft limit negative side while the value of the soft limit positive side was 200.3mm.</p> <p>Treatment : Change the value to the appropriate one.</p>																
0A3	Operation release	Position command data error	<p>Cause : The command value during direct numeric specification exceeded the maximum set value.</p> <p>Treatment : Exceeded command item code is displayed in the detailed code. Input an appropriate value by referring to these values.</p> <table border="1" style="margin-left: auto; margin-right: auto;"> <thead> <tr> <th>Detailed Code (Command Item Code)</th> <th>Command Item</th> </tr> </thead> <tbody> <tr> <td>0</td> <td>Target Position</td> </tr> <tr> <td>2</td> <td>Command Speed</td> </tr> <tr> <td>4</td> <td>Acceleration</td> </tr> <tr> <td>6</td> <td>Deceleration</td> </tr> <tr> <td>8</td> <td>Positioning Width</td> </tr> <tr> <td>C</td> <td>Pressing Current Limit Value</td> </tr> <tr> <td>D</td> <td>Control Signal</td> </tr> </tbody> </table>	Detailed Code (Command Item Code)	Command Item	0	Target Position	2	Command Speed	4	Acceleration	6	Deceleration	8	Positioning Width	C	Pressing Current Limit Value	D	Control Signal
Detailed Code (Command Item Code)		Command Item																	
0	Target Position																		
2	Command Speed																		
4	Acceleration																		
6	Deceleration																		
8	Positioning Width																		
C	Pressing Current Limit Value																		
D	Control Signal																		
0A5	Electromagnetic brake unreleased error	<p>Cause : The brake cannot be released.</p> <p>Treatment : Supplied the 24V power unit for the electromagnetic brake.</p>																	
0A6	Cold start	Dynamic brake not released	<p>Cause : The dynamic brake cannot be released when the servo is ON due to noise and electrostatic, etc.</p> <p>Treatment : Implement measures to eliminate noise or electrostatic. There is a concern of circuit breakdown. Please contact IAI.</p>																



Alarm Code	Alarm Level	Alarm Name	Cause/Treatment
0A7	Operation release	Command deceleration error	<p>Cause : Because there is not enough deceleration distance when the deceleration is changed to a lower setting during the operation, the actuator exceeded the soft limit when deceleration was made from the current position with the deceleration after the change.</p> <p>Treatment : Make the timing earlier for the movement command for the deceleration speed change.</p>
0A8	Cold start	Unsupported motor/encoder types	<p>Cause : The motor connected to the controller is not applicable or the type of the encoder that the motor is connected is not applicable.</p> <p>Treatment : Please contact us if the alarm is issued even with the applicable actuator and the same problem happens again even after rebooting the power.</p>
0A9		Loadcell data error	<p>Cause : The data acquired from loadcell at power-on or software reset is incorrect.</p> <p>Treatment : 1) Effect of noise is suspected. Check if there is a device radiating the noise and have a treatment to prevent receiving the noise. 2) The loadcell may be faulty. If the error keeps occurring even with the power reboot for several times, it is considered the loadcell is malfunctioned. Please contact IAI.</p>
0AD	Operation release	Press program data error	<p>Cause : Program check was conducted at the controller startup, at the program start command and at the program home position movement command, and error was detected.</p> <p>Treatment : As there is a program number stored in the detail code, check the applicable program setting.</p>
0B4	Cold start	Electric angling mismatching	<p>Cause : This alarm indicates that the position deviation counter has overflowed.</p> <p>Treatment : The alarm occurs when the actuator cannot be operated. Confirm about the load conditions, that the work does not interfere with any object nearby or the brake has been released, etc. If the error occurs even when the servo is ON, the cable breakage or disconnection is considered. Check the cable connection. Please contact IAI if there is no failure in the cable and connector connections.</p>
0B5	Operation release	Z-Phase position error	<p>The position where the Z-phase is detected before the home return operation, is out of the specified range.</p> <p>Cause : Encoder error</p> <p>Treatment : Please contact IAI.</p>

Alarm Code	Alarm Level	Alarm Name	Cause/Treatment
0BA	Operation release	Home sensor non-detection	<p><b>Cause</b> : This indicates that the home-return operation of the actuator equipped with origin sensor (option except rotary actuator) is not completed in normal condition.</p> <ol style="list-style-type: none"> <li>1) Work is interfering with peripheral equipment in the middle of home return.</li> <li>2) Large slide resistance of the actuator itself</li> <li>3) Installation failure, breakdown or disconnection of the home sensor</li> </ol> <p><b>Treatment</b> : In the case that the work does not interfere with anything, the cause 2) or 3) is supposed. In such case, please contact IAI.</p>
0BE		Home return timeout	<p><b>Cause</b> : Home return does not complete after elapse of a certain period after the start of home return.</p> <p><b>Treatment</b> : This error does not occur in normal operation. The combination of the controller and actuator may be incorrect. Please contact IAI.</p>
0BF		Creep sensor not detected	<p><b>Cause</b> : This indicates the actuator detected the creep sensor (option) before detecting the origin sensor (option except for rotary actuator), or the actuator reached the mechanical end (or the actuator cannot move anymore because the load is too large).</p> <ol style="list-style-type: none"> <li>1) The position to apply the creep sensor is not appropriate.</li> <li>2) The creep sensor is faulty.</li> <li>3) The cable is disconnected or the connector is not plugged in properly.</li> <li>4) The actuator cannot move due to heavy load caused by interference.</li> </ol> <p><b>Treatment</b> : 1) Readjust the sensor installation position. 2) Replace the creep sensor. 3) Perform continuity check to see if the connector is plugged in properly. 4) Check the interference and the transportable weight and make sure there is no external force applied.</p>
0C0	Operation release	Actual speed excessive	<p><b>Cause</b> : This indicates the number of motor rotation exceeded the number of allowable rotation.</p> <ol style="list-style-type: none"> <li>1) The slide resistance of the actuator is locally high.</li> <li>2) The load is increased too much due to a external force. With the reasons above, it can be considered a sudden speed increase has occurred before detecting the servo error.</li> </ol> <p><b>Treatment</b> : Even though this would not occur in normal operation, check if there is any abnormality in the parts assembly condition. Also check if there is a possibility that an external force may be applied in the direction of the actuator movement.</p>
0C2		Overrun sensor detected	<p><b>Cause</b> : This indicates that a signal from the OT sensor (option) installed at the mechanical end is detected.</p> <ol style="list-style-type: none"> <li>1) The actuator was moved by hand or received external force while the servo was OFF (normal detection).</li> <li>2) The actuator was jogged or operated by pulse-train in a condition where the home coordinates were not yet established and thus the soft stroke limit did not function correctly (normal detection).</li> <li>3) The home position achieved by home return is not correct, or in the case of an absolute type controller the coordinates have shifted due to an inappropriate absolute reset position.</li> <li>4) There is a mismatch between the sensor characteristics and the setting in Parameter No.19 [Overrun sensor input polarity], or the wiring layout is wrong.</li> <li>5) There is a mistake in the mating of the controller and actuator, or the settings in Parameters No.3 and 4 [Soft limit value] and Parameter No.77 [Ball screw limit length] are not appropriate.</li> </ol> <p><b>Treatment</b> : If 1) or 2) is suspected, move the actuator in the opposite direction by hand. If this error occurred inside the effective stroke range, 3), 4), or 5) is a likely cause. If 3) is suspected, check the home position. Conduct the absolute reset again if it is the absolute type. If 4) or 5) is suspected, please contact IAI.</p>

Alarm Code	Alarm Level	Alarm Name	Cause/Treatment
0C4	Cold start	Exceeded allowable time of exceeding torque allowing continuous pressing	<p>Cause : The continuous pressing time exceeds the time set for parameter No.89 [Allowable time of exceeding torque allowing continuous pressing].</p> <p>Treatment : Check the sequence again. Set the pressing time to be within the setting time.</p>
0C6		Torque current • Mismatching force feed back	<p>Cause : The feedback from the loadcell has continuously been larger than the rating motor output for 256 ms or longer.</p> <p>Treatment : 1) Check that there is no external force applied in the direction to push back from the load side. 2) Review wiring of actuator and loadcell cables. 3) The actuator, controller or loadcell may be faulty. Please contact IAI.</p>
0C8		Overcurrent	<p>Cause : The output current in the power circuit section is increased abnormally. There is a concern of malfunction in controller component (IPM).</p> <p>Treatment : This alarm will not be generated in normal operation. If it occurs, insulation of the motor coil may have deteriorated. Check if there is deterioration in the insulation by measuring the phase resistance between the monitor connection lines U, V and W. The values for the phase resistance should be almost the same. There is a concern the insulation is deteriorated if the values are different in large amount. Please contact IAI.</p>
0CA		Overheat	<p>Cause : This indicates overheat (95°C or more) of the components inside the controller. 1) Operation is performed with the load condition exceeding the specified range. 2) High temperature around the controller. 3) Load to the motor is high due to external force. 4) A faulty part inside the controller.</p> <p>Treatment : 1) Revise the operation condition such as decreasing the acceleration/deceleration speed. 2) Lower the ambient temperature of the controller. 3) Confirm that there is no error in the mechanical part assembly condition.</p> <p>(Note) This error would not normally occur. If it occurs, confirm there is not 1) or 2) above. If the same error is issued again even after confirming 1) or 2) is not in the condition, it is considered to be a malfunction. Please contact IAI.</p>
0CB		Current sensor offset adjustment error	<p>Cause : An error was found to the sensor in the status check of the current detection sensor conducted at the initializing process in the startup. 1) The current detection sensor or any of its surrounding parts is faulty. 2) Inappropriate offset adjustment</p> <p>Treatment : A work (PC board) change or offset adjustment is required. Please contact IAI.</p>
0CD		Emergency-stop relay	<p>Cause : A melt-down of the emergency stop relay inside the controller.</p> <p>Treatment : The relay or controller must be replaced. Please contact IAI.</p>
0CE		Drop in control supply voltage	<p>Cause : 1) The AC power supply voltage is low. 2) Faulty part inside the controller</p> <p>Treatment : Check the voltage of the input power supply. In the case that the voltage is normal, please contact IAI.</p>

Alarm Code	Alarm Level	Alarm Name	Cause/Treatment
0CF	Operation release	I/O 24V power supply error	<p>Cause : 24V power supply for PIO is not connected. The voltage is extremely low.</p> <p>Treatment : Check the connection and voltage.</p>
0D2	Cold start	Motor power source voltage excessive	<p>Cause : A breakdown of the part inside the controller is considered.</p> <p>Treatment : If this error occurs frequently, the controller may be faulty at high probability. Please contact IAI.</p>
0D3		Motor power supply voltage low	<p>Cause : 1) If the power source is shut off out of the controller, servo-ON command was made during the power is shut. 2) There is a concern of a malfunction of the controller internal components.</p> <p>Treatment : 1) Check the controller external circuit. 2) If this error occurs often, there is a concern of a controller malfunction. Please contact us.</p>
0D6	Operation release	FAN error detection	<p>Cause : The number of the FAN revolution has dropped to the alarm level.</p> <p>Treatment : Check if the FAN is connected properly, and if this alarm cannot be solved, degradation or malfunction of the FAN can be considered. Replace the FAN.</p>
0D7	Cold start	Belt breaking sensor detected	<p>Cause : The belt of the ultra-high thrust RCS2-RA13R is broken.</p> <p>Treatment : Belt must be replaced. Please contact IAI.</p>
0D8	Operation release	Deviation overflow	<p>Cause : This alarm indicates that the position deviation counter has overflowed.</p> <p>1) The speed dropped or the actuator stopped due to the effect of external force or overload. 2) The excited-phase detection operation following the power-on is unstable. 3) The power supply voltage dropped. 4) Servo gain number is too small 5) There is a concern of malfunction in controller component (IPM).</p> <p>Treatment : 1) This error occurs when the actuator cannot be operated as it is commanded. Check the load conditions such as if the work is touching to the surrounding object, or brake is properly released, and remove the cause. 2) Overload can be concerned. Revise the transportable weight and redo the home-return operation. 3) Check for the source voltage. 5) Replace the controller (PC board).</p>
0D9		Software stroke limit exceeded	<p>Cause : The current position of the actuator exceeds the software stroke limit.</p> <p>Treatment : Return the actuator to be within the range of the software stroke limit.</p>
0DA		Feed back pulse error	<p>Cause : Feedback pulse data cannot be output within the cycle.</p> <p>Treatment : Take proper measures against noise.</p>
0DC		Pressing motion range over error	<p>Cause : 1) After the pressing operation has complete, the force to push back is too large and the pushed back to the pressing start position. 2) The actuator touched the work during the approach movement before the pressing movement.</p> <p>Treatment : 1) Revise the setting and adjust it so the force to push back gets smaller. 2) Set the approach stage of setting in front in the complete position to shorten the approach distance.</p>

Alarm Code	Alarm Level	Alarm Name	Cause/Treatment
0E0	Cold start	Overload	<p><b>Cause</b> : 1) The work weight exceeds the rated weight, or an external force is applied and the load increased.            2) If the actuator is equipped with a brake, the brake is not released.            3) The slide resistance of the actuator is locally high.</p> <p><b>Treatment</b> : 1) Check the work and its surrounding area to remove the cause.            2) Turn on the brake release switch to see if the brake is released.            If the brake is not released, the brake itself may be faulty, cable may be disconnected, or the controller may be faulty. Please contact IAI.            3) In the case that the work can be moved by hand, move it. Then, check that there is no location where a sliding resistant is too large. Check if the installation face is distorted. When the error occurs in operation of the actuator only, Please contact IAI.</p> <p> <b>Caution</b>            Restart the operation after making sure to remove the cause. If you cannot determine that the cause is removed completely, wait for at least 30 minutes before turning on the power to prevent the motor coil from burning.</p>
0E1	Operation release	Loadcell calibration error	<p><b>Cause</b> : 1) Calibration command is issued during actuator operation, temporary stop or pressing operation.            2) A calibration error occurs when calibration command is issued.            3) The calibration command signal CLBR is set to OFF before the completion of calibration.</p> <p><b>Treatment</b> : 1) Conduct the calibration in the actuator stop condition.            2) Check whether a large load is applied to the loadcell due to biting. Effect of noise is suspected. Check the presence of noise source around the loadcell.            3) In either of 3) and 4), check the sequence again. Malfunction of the loadcell is considered. Replace the loadcell. Please contact IAI.</p>
0E2	Cold start	Loadcell communication error	<p><b>Cause</b> : There was a communication error during the communication with the loadcell.</p> <p><b>Treatment</b> : 1) Review wiring of loadcell cables and others.            2) Effect of noise is suspected. Check the presence of noise source around the loadcell.            3) Replace the loadcell if it may be faulty.            4) Replace the controller if it may be faulty.            In cases 3) and 4), please contact IAI.</p>
0E3		Loadcell error	<p><b>Cause</b> : Loadcell power error, hardware error such as board overheat or EEPROM error occurs.</p> <p><b>Treatment</b> : 1) The effect of noise may be possible. Check the presence of noise source around the loadcell.            2) Replace the loadcell if it may be faulty. Please contact IAI.</p>

Alarm Code	Alarm Level	Alarm Name	Cause/Treatment
0E4	Cold start	Encoder send error	<p><b>Cause</b> : The data sending and receiving between the controller and encoder is conducted by the serial communication. This error indicates that the data sent from the controller was not received properly at the encoder side.</p> <ol style="list-style-type: none"> <li>1) Effect of noise</li> <li>2) One or more communication ICs installed on the encoder board are faulty.</li> <li>3) One or more communication ICs installed on the controller board are faulty.</li> </ol> <p><b>Treatment</b> : 1) Interrupt the power to the peripheral equipment and activate only the actuator. If any error does not occur, it might be caused by noise. Take proper measures against noise.                      If 2) or 3) is the case, the encoder or controller must be replaced.                      If the cause cannot be specified, please contact IAI.</p>
0E5		Encoder receipt error	<p><b>Cause</b> : This shows the data was not received in normal condition from the encoder side to the controller.</p> <ol style="list-style-type: none"> <li>1) Cable breakage of encoder cable or connector connection failure or noise. (If the detail code in the error list of the teaching tool is 0001H.)</li> <li>2) Effect of noise. (If the detail code in the error list of the teaching tool is 0002H.)</li> <li>3) Malfunction of component (communication part) inside the actuator.</li> <li>4) A faulty part inside the controller (communication part).</li> </ol> <p><b>Treatment</b> : 1) Check if any wire breakage on a connector and the condition of wire connections.                      2) Interrupt the power to the peripheral equipment and activate only the actuator. If any error does not occur, it might be caused by noise. Take proper measures against noise.                      If 3) or 4) is the case, it is necessary to replace the actuator (motor part) or controller.                      If the cause cannot be specified, please contact IAI.</p>
0E6		Encoder count error	<p><b>Cause</b> : This error code appears when the encoder cannot detect the position information properly.</p> <ol style="list-style-type: none"> <li>1) The encoder relay cable or supplied actuator cable is disconnected or its connector is not plugged in correctly.</li> <li>2) Foreign matter is deposited on the code wheel.</li> <li>3) The position relationship between the code wheel and photo sensor changed due to shaft center shift caused by application of excessive external force, etc.</li> <li>4) Faulty encoder board component</li> </ol> <p><b>Treatment</b> : 1) Check if any wire breakage on a connector and the condition of wire connections.                      For the case of 2), 3) or 4), it is necessary either to clean the code wheel, adjust the installation position, replace the motor unit or replace the actuator. In any case, please contact IAI.</p>

Alarm Code	Alarm Level	Alarm Name	Cause/Treatment
0E7		A-, B- and Z-phase wire breaking	<p>Cause : Encoder signals cannot be detected correctly.</p> <p>1) The encoder relay cable or supplied actuator cable is disconnected or its connector is not plugged in correctly.</p> <p>2) The encoder itself is faulty.</p> <p>Treatment : 1) Check if any wire breakage on a connector and the condition of wire connections. If the cables are normal, faulty encoder is suspected. Please contact IAI.</p>
0EE	Cold start	Absolute encoder error detection 2	<p>Cause : This is the condition where the position information can not be detected in the absolute encoder.</p> <p>1) Voltage drop of absolute battery.</p> <p>2) The encoder relay cable or supplied actuator cable is disconnected or its connector is not plugged in correctly.</p> <p>Treatment : 1) Replace the absolute battery with new one. 2) Check if any wire breakage on a connector and the condition of wire connections. Whichever action is taken under 1) or 2), an absolute reset must be performed. If the cables are normal, faulty encoder is suspected. Please contact IAI.</p>
0EF		Absolute encoder error detection 3	<p>Absolute encoder is not detecting the position information properly. (ABS encoder overspeed error)</p> <p>Cause : This error occurs in such cases as the speed exceeded the tracing acceleration speed limit in the drop by the brake release at the power cutoff of the absolute type vertical axis. (This condition should not occur in normal conditions of use. Take sufficient note on forced brake release.)</p> <p>Treatment : If the error is occurred, it is necessary to absolute reset.</p>
0F0		Driver logic error	<p>Cause : Exceeded load, parameter (motor type) mismatched, noise, malfunction of controller, etc.</p> <p>Treatment : Please contact IAI.</p>
0F1	Operation release	Fieldbus link error	<p>Cause : This error occurs when the link of the fieldbus is disconnected in a fieldbus type controller.</p> <p>Treatment : It can be considered that there is a setting error in a fieldbus related parameter, setting error in the master, connection error in fieldbus cable or interruption by noise.</p>
0F2		Fieldbus module error	<p>Cause : A Field bus Module error was detected.</p> <p>Treatment : Check the Field bus related parameters.</p>
0F3		Fieldbus module not detected	<p>Cause : Field bus module not detected.</p> <p>Treatment : If the error cannot be resolved even after putting the power on again, please contact us.</p>
0F4	Cold start	Mismatched PCB	<p>This controller uses a different print circuit board depending on the motor capacity. The PCB is not applicable for the connected motor in the startup check.</p> <p>Cause : The actuator may not match the controller. Check the model.</p> <p>Treatment : Should this error occur, please contact IAI.</p>
0F5		Nonvolatile memory write verify error	<p>It is verified at the data writing process to the nonvolatile memory that the data inside the memory and the data to be written are matched. There was a mismatch detected in this process.</p> <p>Cause : Faulty nonvolatile memory.</p> <p>Treatment : When the error is caused even when the power is re-input, please contact IAI.</p>

Alarm Code	Alarm Level	Alarm Name	Cause/Treatment
0F6	Cold start	Nonvolatile memory write timeout	There is no response in the specified time duration during the data writing to the nonvolatile memory. Cause : Faulty nonvolatile memory. Treatment : When the error is caused even when the power is re-input, please contact IAI.
0F8		Nonvolatile memory data destroyed	Abnormal data was detected during the nonvolatile memory check after starting. Cause : Faulty nonvolatile memory. Treatment : When the error is caused even when the power is re-input, please contact IAI.
0FA		CPU error	The CPU operation is not normal. Cause : 1) Faulty CPU 2) Malfunction due to noise Treatment : When the error is caused even when the power is re-input, please contact IAI.
0FB		FPGA error (Faulty component)	The FPGA is not operating properly. Cause : 1) Malfunction due to the effect of noise, etc. 2) Faulty FPGA 3) Faulty circuit component around the FPGA. 4) Inappropriate board installation in the controller. Treatment : Turn the power off and reboot. If the error occurs again, check for presence of noise. If a spare controller is available, replace the problem controller with the spare controller. A recurring error with the spare controller suggests presence of noise. If the cause cannot be identified, please contact IAI.
0FD		Expanded device error	Cause : Error in load data analog output components (Note) Error will not be detected when Parameter No. 180 DAC Output is set invalid. Treatment : Check in wiring for analog output. Contact IAI if no failure is found in wiring.
100 to 1FF	Message	Alarm on teaching tool	[Refer to the Instruction Manual of teaching tool.]
200 to 2FF	Operation release	Alarm on teaching tool	[Refer to the Instruction Manual of teaching tool.]
300 to 3FF	Cold start	Alarm on teaching tool	[Refer to the Instruction Manual of teaching tool.]



### 8.4.2 Program Alarm (When Controller alarm 094 is issued)

A controller alarm (094: Press Program Alarm Detection) is issued when an alarm is generated during the press program execution. Also, the program alarm code and the alarm occurrence program number are stored in the detail code of 094 Alarm.

- Detail Code (Upper bytes): Alarm generation program No.
- Detail Code (Lower bytes): Alarm Code

The alarm codes are classified into three types.

- Genre1: Program execution condition error (Occurs at program start command)
- Genre2: Error in the setting to the program (Occurs at program start command and program home position movement command)
- Genre3: Error in program execution (Occurs during program execution)

Alarm Code	Name	Genre	Remarks
01	Program start at home-return incomplete	1	Cause : A position move command was issued before home return was completed. Treatment : Issue a command after confirming that home return has been completed (HEND) is ON.
02	Program start at loadcell calibration incomplete	1	Cause : A program start command was input while the loadcell calibration is incomplete. Treatment : After confirming the loadcell calibration is completed with the calibration complete (CEND) signal, and confirming CLBR Signal is turned OFF, perform the program startup.
03	Program start at axis operation	1	Cause : 1) A program start command was input while in actuator operation. 2) Actuator movement command was input at the same time as program start command. Treatment : Check the command timing.
10	Command program No. error	2	Cause : The indicated program number was out of range from 0 to 63. Treatment : Check the command program No. on the host side.
11	Invalid program indication	2	Cause : A program number was indicated which no program is set / registered. Treatment : Check the command program No. on the host side.
12	Program home coordinate error	2	Cause : The set program home position is out of the range of the soft limit. Treatment : Correct the program home coordinate so softlimit gets in the range
13	Approach speed error	2	Cause : The approach speed exceeds the max. speed of the actuator. Treatment : Refer to the catalog and actuator instruction manual, and make sure not to exceed the max. speed. (Note) Error detection will not take place if the approach stage is not held.
14	Approach acceleration error	2	Cause : The approach acceleration exceeds the actuator max. acceleration. Treatment : Refer to the catalog and actuator instruction manual, and make sure not to exceed the max. acceleration. (Note) Error detection will not take place if the approach stage is not held.

Alarm Code	Name	Genre	Remarks
15	Approach deceleration error	2	<p>Cause : The approach deceleration exceeds the actuator max. deceleration.</p> <p>Treatment : Refer to the catalog and actuator instruction manual, and make sure not to exceed the max. deceleration.</p> <p>(Note) Error detection will not take place if the approach stage is not held.</p>
16	Approach complete position error	2	<p>Cause : The set approach complete position is out of the range of the soft limit.</p> <p>Treatment : Revise the setting so it gets in the soft limit range.</p> <p>(Note) Error detection will not take place if the approach stage is not held.</p>
17	Approach max. load error	2	<p>Cause : The set approach max. load exceeds the actuator max. pressing force.</p> <p>Treatment : Refer to the catalog and actuator instruction manual, and make sure not to exceed the specification.</p> <p>(Note) Error detection will not take place if the approach stage is not held.</p>
18	Probing speed error	2	<p>Cause : The probing speed exceeds the actuator pressing speed.</p> <p>Treatment : Refer to the catalog and actuator instruction manual, and make sure not to exceed the max. speed.</p> <p>(Note) Error detection will not take place if the probing stage is not held.</p>
19	Probing acceleration error	2	<p>Cause : The probing acceleration exceeds the actuator max. acceleration.</p> <p>Treatment : Refer to the catalog and actuator instruction manual, and make sure not to exceed the max. acceleration.</p> <p>(Note) Error detection will not take place if the probing stage is not held.</p>
1A	Probing deceleration error	2	<p>Cause : The probing deceleration exceeds the actuator max. deceleration.</p> <p>Treatment : Refer to the catalog and actuator instruction manual, and make sure not to exceed the max. deceleration.</p> <p>(Note) Error detection will not take place if the probing stage is not held.</p>
1B	Probing complete load error	2	<p>Cause : The set probing complete load exceeds the actuator max. pressing force.</p> <p>Treatment : Refer to the catalog and actuator instruction manual, and make sure not to exceed the specification.</p> <p>(Note) Error detection will not take place if the probing stage is not held.</p>
1C	Probing limit position error	2	<p>Cause : The set probing limit position is out of the range of the soft limit.</p> <p>Treatment : Revise the setting so it gets in the soft limit range.</p> <p>(Note) Error detection will not take place if the probing stage is not held.</p>
1D	Decompressing speed error	2	<p>Cause : The decompressing speed exceeds the actuator max. pressing speed.</p> <p>Treatment : Refer to the catalog and actuator instruction manual, and make sure not to exceed the pressing speed.</p> <p>(Note) Error detection will not take place if the decompressing stage is not held.</p>

Alarm Code	Name	Genre	Remarks
1E	Decompressing acceleration error	2	<p>Cause : The decompressing acceleration exceeds the actuator max. acceleration.</p> <p>Treatment : Refer to the catalog and actuator instruction manual, and make sure not to exceed the max. acceleration.</p> <p>(Note) Error detection will not take place if the decompressing stage is not held.</p>
1F	Decompressing deceleration error	2	<p>Cause : The decompressing deceleration exceeds the actuator max. deceleration.</p> <p>Treatment : Refer to the catalog and actuator instruction manual, and make sure not to exceed the max. deceleration.</p> <p>(Note) Error detection will not take place if the decompressing stage is not held.</p>
20	Decompressing complete load error	2	<p>Cause : The set decompressing complete load exceeds the actuator max. pressing force.</p> <p>Treatment : Refer to the catalog and actuator instruction manual, and make sure not to exceed the specification.</p> <p>(Note) Error detection will not take place if the decompressing stage is not held.</p>
21	Retruning speed error	2	<p>Cause : The returning speed exceeds the actuator max. deceleration.</p> <p>Treatment : Refer to the catalog and actuator instruction manual, and make sure not to exceed the max. speed.</p> <p>(Note) Error detection will not take place if the probing stage is not held.</p>
22	Retruning acceleration error	2	<p>Cause : The returning acceleration exceeds the actuator max. acceleration.</p> <p>Treatment : Refer to the catalog and actuator instruction manual, and make sure not to exceed the max. acceleration.</p> <p>(Note) Error detection will not take place if the probing stage is not held.</p>
23	Retruning deceleration error	2	<p>Cause : The returning deceleration exceeds the actuator max. deceleration.</p> <p>Treatment : Refer to the catalog and actuator instruction manual, and make sure not to exceed the max. deceleration.</p> <p>(Note) Error detection will not take place if the probing stage is not held.</p>
24	Pressurize speed error	2	<p>Cause : The pressurize speed exceeds the actuator pressing speed.</p> <p>Treatment : Refer to the catalog and actuator instruction manual, and make sure not to exceed the pressing speed.</p>
25	Pressurize acceleration error	2	<p>Cause : The pressurize acceleration speed exceeds the actuator max. acceleration speed.</p> <p>Treatment : Refer to the catalog and actuator instruction manual, and make sure not to exceed the max. acceleration.</p>
26	Pressurize deceleration error	2	<p>Cause : The pressurize deceleration speed exceeds the actuator max. deceleration speed.</p> <p>Treatment : Refer to the catalog and actuator instruction manual, and make sure not to exceed the max. deceleration.</p>

Alarm Code	Name	Genre	Remarks
27	Pressurize max. load, Pressurize complete load, Pressurize target load error	2	<p>Cause : The following set loads exceed the actuator max. pressing force.</p> <p>1) Pressurize max. load 2) Pressurize complete load 3) Pressurize complete incremental load 4) Pressurize target load 5) Pressurize target incremental load</p> <p>Treatment : Refer to the catalog and actuator instruction manual, and make sure not to exceed the specification.</p>
28	Pressurize complete position, Pressurize limit position error	2	<p>Cause : The following set position is out of the range of the soft limit.</p> <p>1) Pressurize complete position 2) Pressurize complete distance 3) Pressurize limit position</p> <p>Treatment : Revise the setting so it gets in the soft limit range.</p>
29	Speed switch load error	2	<p>Cause : The set deceleration start load, or deceleration start incremental load exceeds the actuator max. pressing force.</p> <p>Treatment : Refer to the catalog and actuator instruction manual, and make sure not to exceed the specification.</p>
2A	Speed switch position error	2	<p>Cause : The set deceleration start load, or deceleration start distance is out of the range of the soft limit.</p> <p>Treatment : Revise the setting so it gets in the soft limit range.</p>
2B	Switchover speed error	2	<p>Cause : The set switchover setting, exceeds the setting of pressurize speed.</p> <p>Treatment : Establish the setting to make pressurizing speed &gt; switching speed.</p>
2C	Position judgment upper limit error	2	<p>Cause : The set position judgement upper limit is out of the range of the soft limit.</p> <p>Treatment : Revise the setting so it gets in the soft limit range.</p>
2D	Position judgment lower limit error	2	<p>Cause : The set position judgement lower limit is out of the range of the soft limit.</p> <p>Treatment : Revise the setting so it gets in the soft limit range.</p>
2E	Load judgment upper limit error	2	<p>Cause : The set load judgement upper limit is out of the range of the soft limit.</p> <p>Treatment : Refer to the catalog and actuator instruction manual, and make sure not to exceed the specification.</p>
2F	Load judgment lower limit error	2	<p>Cause : The set load judgement lower limit is out of the range of the soft limit.</p> <p>Treatment : Refer to the catalog and actuator instruction manual, and make sure not to exceed the specification.</p>
30	Position data size relation unintegrated	2	<p>Cause : The formulas of 1) and 2) below are not satisfied.</p> <p>1) Approach complete position &lt; Probing limit position ≤ Pressurize complete position 2) Program home &lt; Probing limit position</p> <p>Treatment : Establish the setting to have the formulas satisfied.</p> <p>(Note) Check the approach complete position will not take place if the approach stage is not held.</p>

Alarm Code	Name	Genre	Remarks
31	Position judgment data size relation unintegrated	2	<p>Cause : The set position judgement upper limit is less than position judgement lower limit.</p> <p>Treatment : Establish the setting to make Position judgement upper limit &gt; Position judgement lower limit</p>
32	Load judgment data size relation unintegrated	2	<p>Cause : The set load judgement upper limit is less than load judgement lower limit.</p> <p>Treatment : Establish the setting to make Load judgement upper limit &gt; Load judgement lower limit</p>
33	Program allowable time error	2	<p>Cause : The set allowable programming time is shorter than the stop time.</p> <p>Treatment : Establish the setting to make Program allowable time &gt; Stop time</p>
40	Approach max. load over	3	<p>Cause : The load exceeded the set max. approach load during approaching operation.</p> <p>Treatment : Check the setting of approach max. load. Check the setting of approach end position. Check if there is any interference of the loadcell to peripheral equipment during actuator operation.</p>
41	Probing limit position over	3	<p>Cause : The actuator current position exceeded the probing limit position during probing operation.</p> <p>Treatment : Check if a work piece is set on the equipment. Check the setting of probing limit position.</p>
42	Pressurizing complete absolute Position error	3	<p>Cause : The final target position of pressurize operation is out of the range of the soft limit in select distance complete mode.</p> <p>Treatment : Revise the setting so make sure not to exceed the soft limit.</p>
43	Final target load error	3	<p>Cause : The final target load in pressurizing operation exceeds the max. pressing force when the incremental load stop mode is selected.</p> <p>Treatment : Refer to the catalog and actuator instruction manual, and make sure not to exceed the specification.</p>
44	Pressurize max. load over	3	<p>Cause : It has exceeded the max. load set during the pressurizing operation when the position stop or distance stop mode was selected.</p> <p>Treatment : Have such an action as to revise the maximum load setting so it would not exceed the set load.</p>
45	Pressurize limit position over	3	<p>Cause : It has exceeded the pressurizing limit position set during the pressurizing operation when the load stop or incremental load stop mode was selected.</p> <p>Treatment : Have an adjustment to exceed pressurizing limit position.</p>

Alarm Code	Name	Genre	Remarks
46	Pressurize allowable time over	3	Cause : Pressurizing does not finish even exceed operation allowable time during pressurize operation. Malfunction of the damage etc. on a work piece. Treatment : Have an adjustment to finish pressurizing in the operation allowable time.
47	Force control stop range exceeded	3	Cause : Actuator exceeded the stop range at stop in the force control mode. Treatment : Have an adjustment to finish pressurizing in the stop range.
48	Decompressing limit position over	3	Cause : Depressurizing does not finish even after moving to the program home position. Malfunction of the loadcell or a work piece getting stuck is concerned. Treatment : Check that a work piece does not interfere with the loadcell. After that, have the loadcell calibrated. Contact IAI if the problem does not get solved.
49	Position (distance) judgement NG	3	Cause : Failure was detected in the position (distance) judgment.
4A	Load judgement NG	3	Cause : Failure was detected in the load judgment.
4B	Program execution time exceeded	3	Cause : Program does not finish even after allowable programming time. Treatment : Check the settings of each stages.
4C	Movement command during the program execution.	3	Cause : A movement command (home-return, JOG, inching or program home position movement command) was detected during program execution. Treatment : Have other movement command not to be input during the program execution.
4D	Startup program during the program execution.	3	Cause : Start command of another program was detected during the program execution. Treatment : Have other movement command not to be input during the program execution.
4E	Allowable velocity exceeded at press motion before contacting work piece	3	Cause : In the press motion before detecting contact to a work piece, the pressing speed or switching speed has exceeded the maximum pressing velocity Treatment : Decrease the velocity setting at the pressure motion or conduct the pressure motion after confirming contact to a work piece.

## Chapter 9 Appendix

### 9.1 Way to Set Multiple Controllers with 1 Teaching Tool

It is usually necessary to connect the teaching tool to the controllers one by one when making a setup to multiple controllers with one unit of teaching tool. In this section, explains how to perform the settings without connecting and disconnecting the plug.

• Requisite devices :

(1) SIO Converter (RCB-TU-SIO-A or RCB-TU-SIO-B) : 1 unit

(2) Controller Link Cable (CB-RCB-CTL002) : Required by the number of controllers

Accessories ( 1) 4-way junction (Manufactured by AMP 5-1473574-4) : 1 unit  
 ( 2) e-CON Connector (Manufactured by AMP 4-1473562-4) : 1 unit  
 ( 3) Terminal Resistance (220Ω, with a e-CON connector) : 1 unit

Instead of the e-CON cable attached to the controller link cable, a terminal block may be used. In this configuration, disconnect the e-CON connector from the controller link cable.

#### 9.1.1 Connecting Example

Shown below is an example of connection.

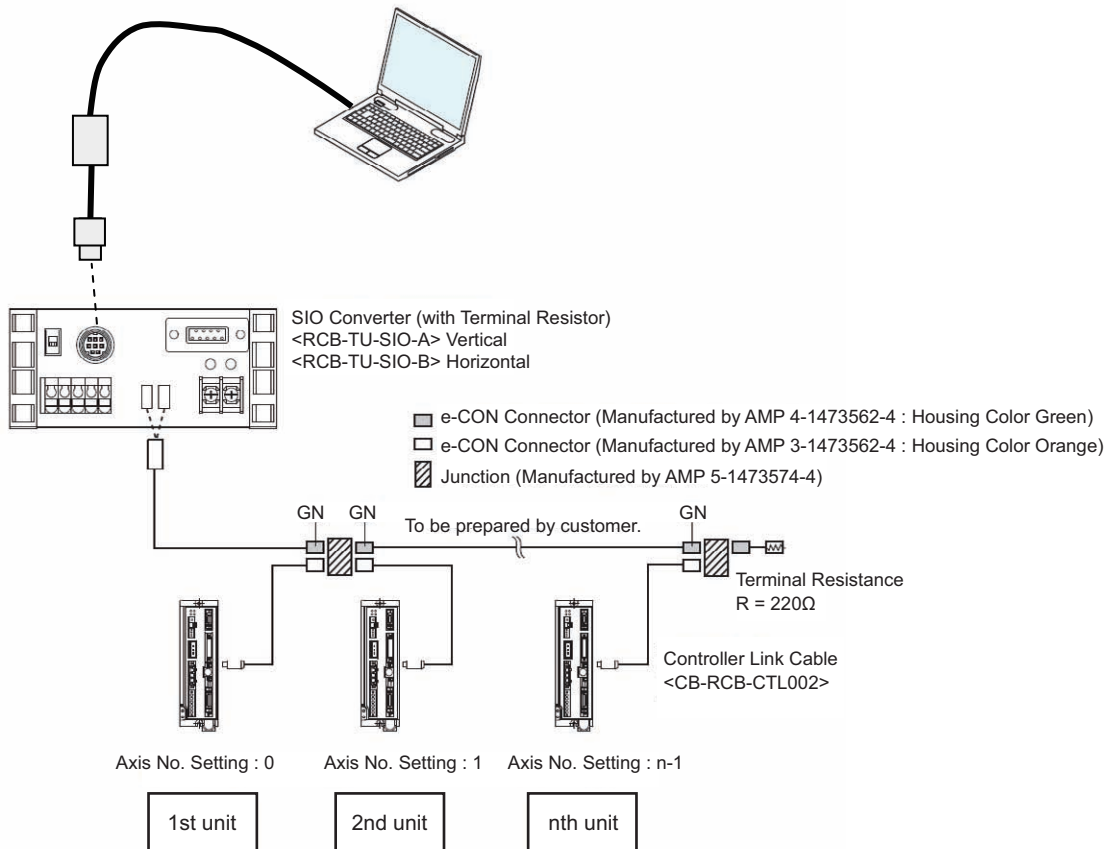

### 9.1.2 Detailed Connection Diagram of Communication Lines

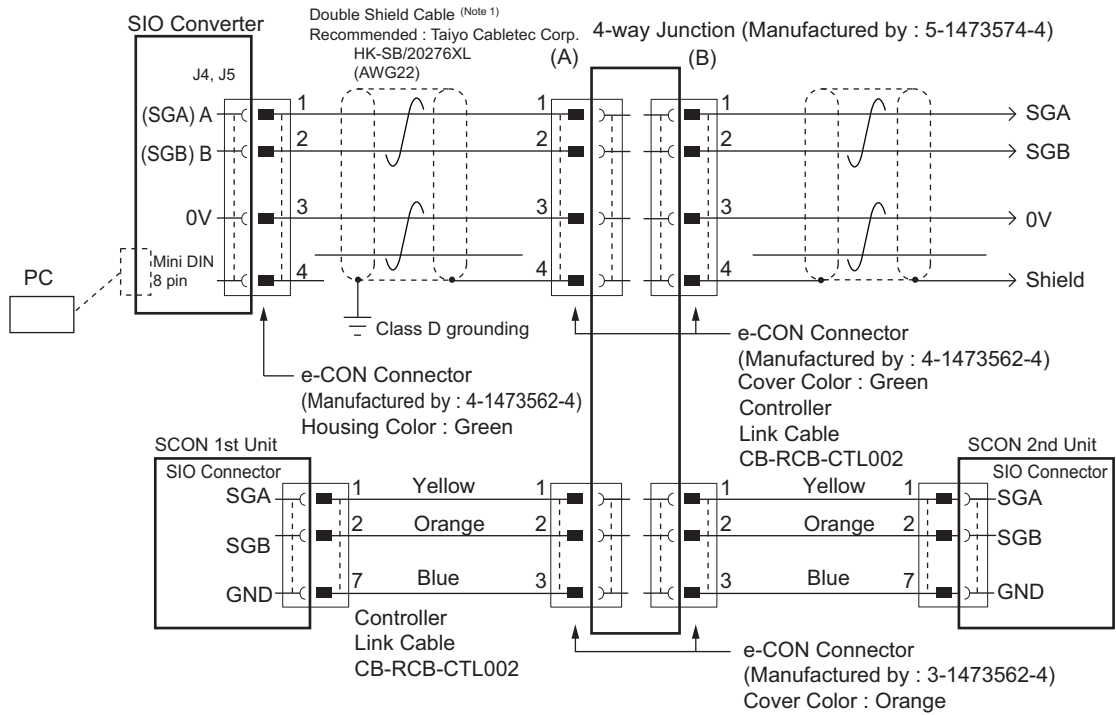

(Note 1) Apply a 2-pair shielded cable.

When connecting a cable other than recommended to (A) and (B), make sure to use a hard-cored cable equivalent to the vinyl cable dedicated for control devices with the sheath outer diameter from 1.35 to 1.60mm. Using cables with outer diameter out of the specification may cause poor contact to occur.

**Caution :** When cables with outer diameter out of the specification are used, use a terminal block instead of 4-direction junction. In this configuration, disconnect the e-CON connector of the link cable. If an error possibly caused by poor contact occurs frequently, replace the junction with the terminal block.





## 9.1.3 Axis No. Setting

---

Set an axis number by using the axis number setting switch on the front panel.

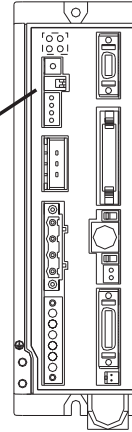
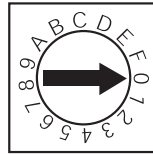
Adjust the arrow to a desired position using a slotted screwdriver.



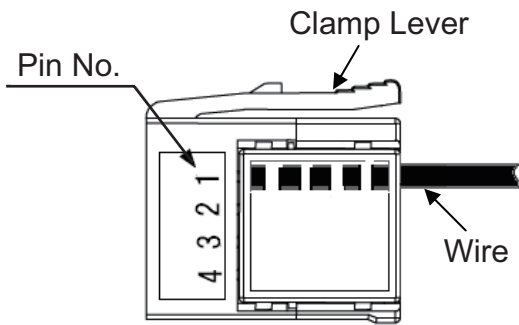

 Caution : The axis number must be unique.

### 9.1.4 Handling of e-CON Connector (How to Connect)

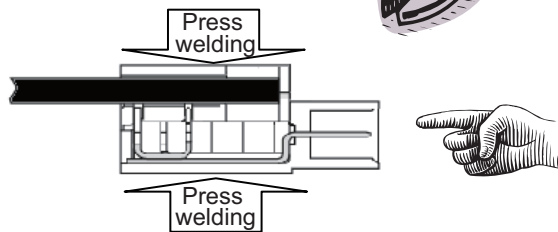
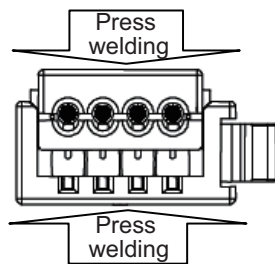
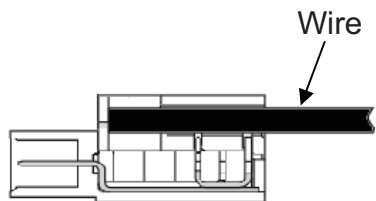

- 1) Check the applicable cable size.  
Check the applicable cable. If it is not applicable, it may cause a connection failure or a breakage of the connector.
- 2) Check the pin numbers, do not reveal the sheath, and insert the cable till it reaches the end. Revealing the sheath may cause a failure such as short circuit or cable fall out.



- 3) Use a (generally purposed) parallel plier with the width of 10mm or more to press-weld the cable from top and bottom. Use the parallel plier from the direction of , grip it while checking the condition of press-welding to make sure the press is in right angle and press it until it becomes completely flat to the housing. If the inserting is not enough, it may not be able to attach to the socket or may cause a contact failure.
- 4) After finishing the press-welding, pull the cable lightly to confirm that won't come out.

**⚠ Caution :**

- 1) e-CON connector cannot be reused once the press-welding is failed. Use a new connector to retry the press-welding.
- 2) When connecting to the socket, hold the connector with care not to touch the clamp lever, insert the connector in parallel to the socket until the clamp lever makes a "click" sound.
- 3) After joining to the socket, do not pull the cables or pull the connector without releasing the lock of the clamp lever.

### 9.1.5 SIO Converter

The SIO converter converts the communication mode from RS232C to RS485 or vice versa.

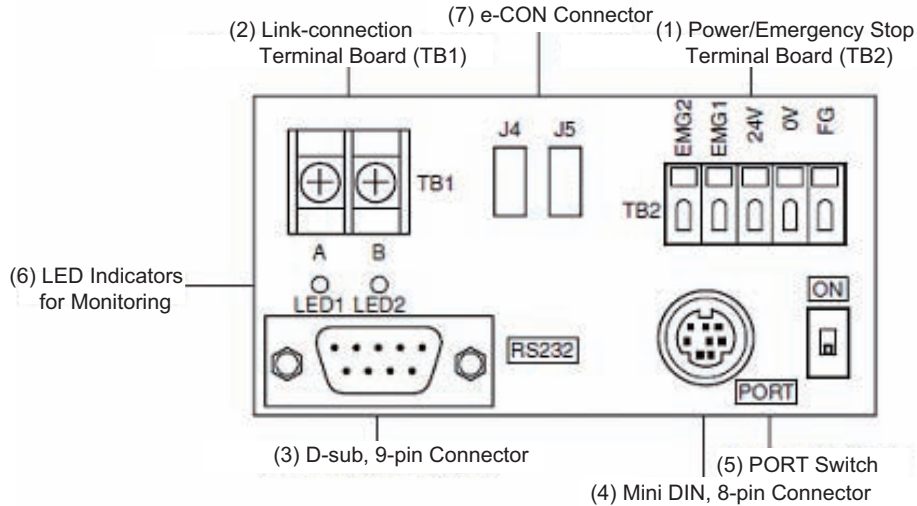

#### (1) Power/Emergency Stop Terminal Board (TB2)

Symbol	Description
EMG1, EMG2	Turn the PORT switch ON to output the emergency stop switch signal, OFF to short-circuit EMG1 and EMG2. When applying the emergency stop switch of the teaching pendant to the emergency stop of the system, obtain the signal from here.
24V	Positive side of the 24V DC power supply (Power supply for the teaching pendant and conversion circuit.)
0V	Negative side of the 24V DC power supply
FG	Frame ground

(Note) 0V is connected to the pin No. 7 (GND) on the communication connector for the controller.

- Connection method

Use a connection cable satisfying the following specifications :

Item	Specification
Applicable wire	Solid Wire : $\phi 0.8$ to 1.2mm/Stranded : AWG Size 20 to 18 (0.5 to 0.75mm <sup>2</sup> )
Stripped wire length	10mm

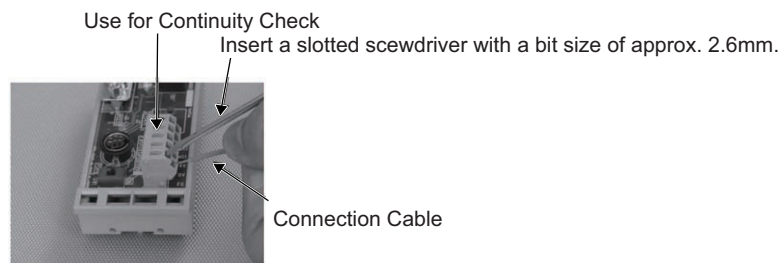

- (2) Link-connection Terminal Board (TB1)  
This is the connection port to obtain communication connection with the controller.  
Connect terminal "A" on the left side to communication line SGA of the controller. (Terminal A is connected to pin 1 of (7) internally.)  
Connect terminal "B" on the right side to communication line SGB of the controller. (Terminal B is connected to pin 2 of (7) internally.)  
Use a twisted pair shielded cable for the connection of SGA and SGB to TB1.
- (3) D-sub, 9-pin connector  
A connection port with the PC. (RS232C)  
It is used when the operation is conducted with using SIO communication.
- (4) Mini DIN, 8-pin connector  
This connector is connected to "PC software", teaching pendant.
- (5) PORT Switch  
The PORT switch is used to exchange enable/disable of connector (4).  
Set the switch to ON if connector (4) is used or OFF if not used.  
The switchover of valid/invalid on the teaching pendant is held at the same time as the emergency stop button switch signal output (between EMG1 and 2).
- (6) LED Indicators for Monitoring  
LED1 : Lights/blinks while the controller sends signals.  
LED2 : Lights/blinks while signals are sent from the RS232C connector.
- (7) e-CON Connector  
It is used when connecting to the controller with e-CON connector without using 2).

### 9.1.6 Communications

(1) Controller Link Cable (CB-RCB-CTL002)

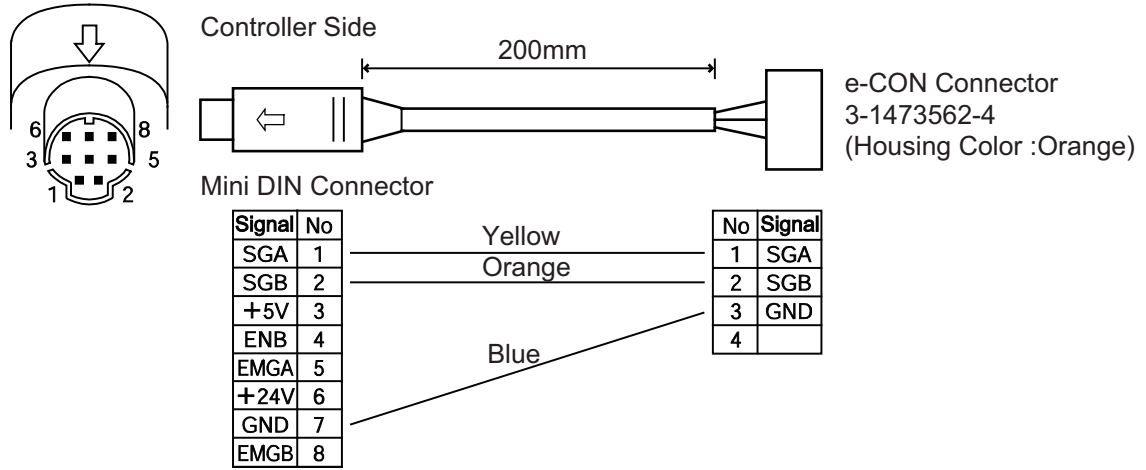

### 9.1.7 External Dimension

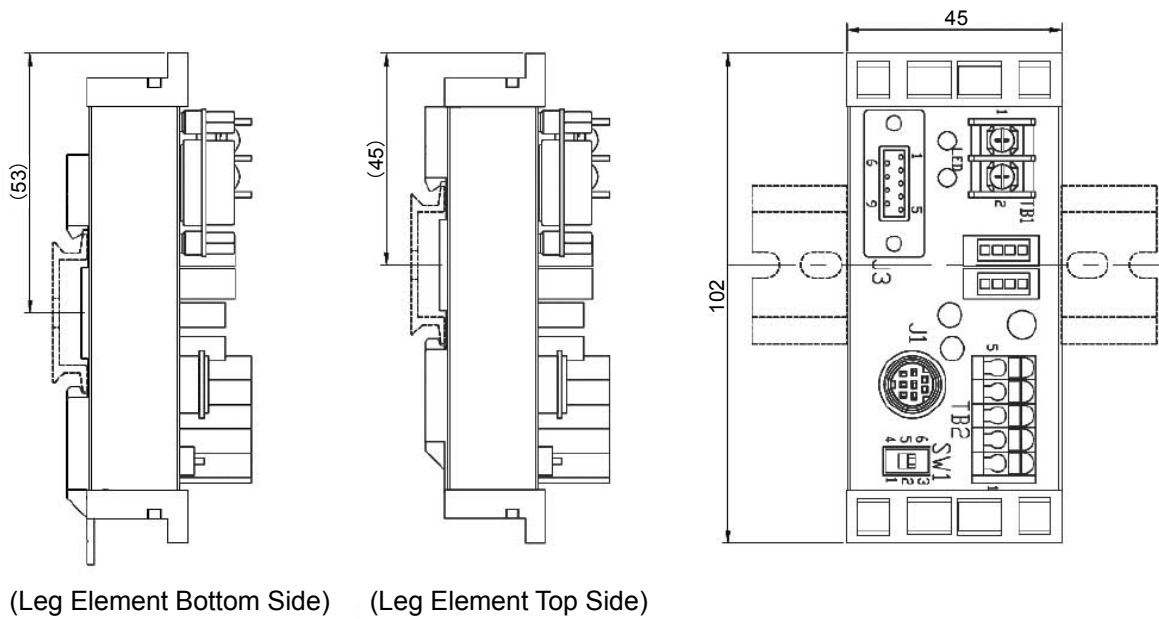

## 9.2 Conformity to Safety Category of to 750W motor corresponding SCON

### [1] System Configuration

Make sure to use the SCON-CGB controller if it is necessary to construct a system complied with Safety Categories (ISO12100-1). Also, when connecting teaching tool, using the PC software.

Also, TP adaptor (Model : RCB-LB-TGS), and Dummy plug (Model: DP-4S) is required.

The system can conform to up to safety category B to 4 (ISO13849-1) by changing connections of system I/O connectors.

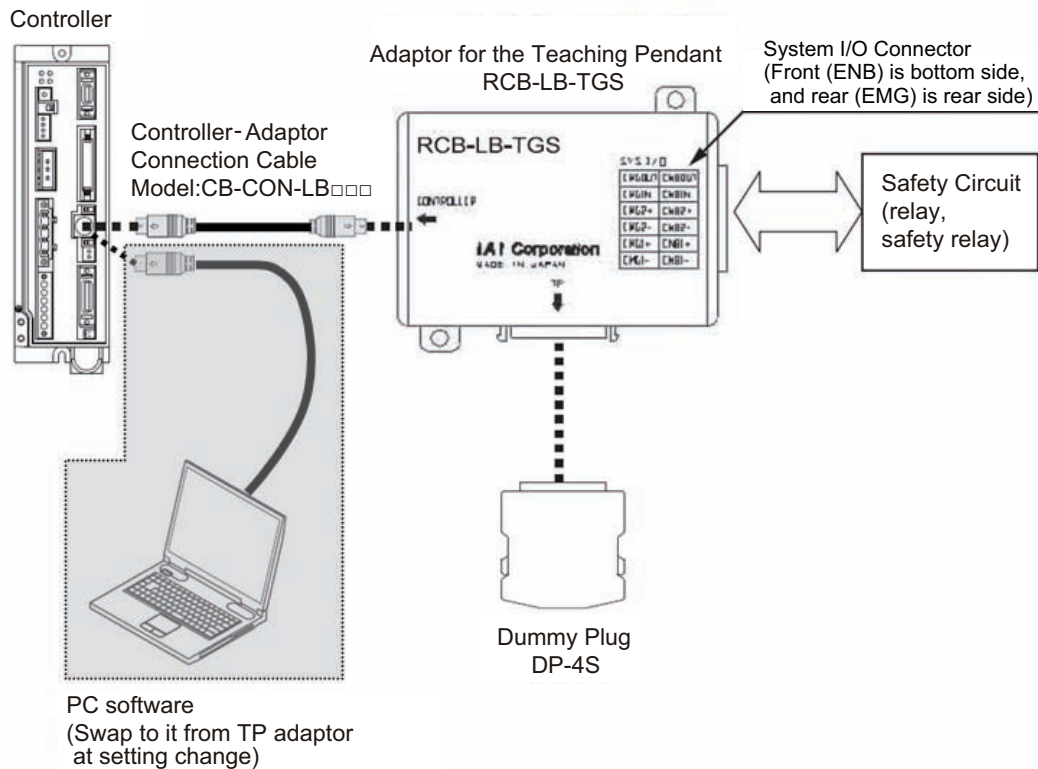

[2] Wiring and Setting of Safety Circuit

(1) Power supply

To use safety relays and/or contactors of 24V DC specification in the safety circuit, the control power supply should be used only for the circuit as much as possible.  
 For instance, do not attempt to use the same power source as the driving power supply for ACON, and PCON which is the controller for ROBO Cylinder, the product of IAI.  
 It is the risk prevention treatment preparing for the cases such as the operation error of the safety circuit caused by not enough power capacity.

(2) Specification of system I/O connector for TP adapter

Connector name		System I/O Connector		Applicable Wire
Upper side (EMG side)	Cable side	FMC1.5/6-ST-3.5 <sup>(Note 1)</sup>	Phoenix Contact	AWG24 to 16 (0.2 to 1.25m <sup>2</sup> )
	TP adapter side	MCDN1.5/6-G1-3.5P26THR		
Lower side (ENB side)	Cable side	FMC1.5/6-ST-3.5 <sup>(Note 1)</sup>		
	TP adapter side	MCDN1.5/6-G1-3.5P26THR		

	Pin No.	Signal Name	Description
Upper side (EMG side)	1	EMG1-	Emergency stop contact 1 (30V DC or less, 100mA or less)
	2	EMG1+	
	3	EMG2-	Emergency stop contact 2 (30V DC or less, 100mA or less)
	4	EMG2+	
	5	EMGIN	Emergency stop detection input
	6	EMGOUT	24V power supply output for emergency stop detection input
Lower side (ENB side)	7	ENB1-	Enable contact 1 (30V DC or less, 100mA or less)
	8	ENB1+	
	9	ENB2-	Enable contact 2 (30V DC or less, 100mA or less)
	10	ENB2+	
	11	ENBIN	Enable detection input
	12	ENBOUT	24V power supply output for enable detection input

Note 1     Connectors on the cable side are attached under conditions where initial wiring has been conducted.  
 In order to support each category, remove the initial wiring and wire your safety circuit.

• Upper side (EMG) connector

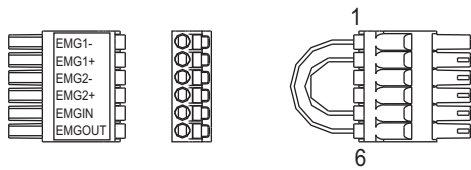

• Lower side (ENB) connector

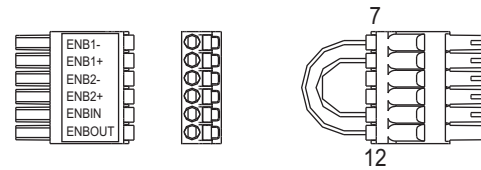

Wiring	Color	Signal	No.
AWG24	Yellow	EMG1-	1
	Yellow	EMG1+	2
	—	EMG2-	3
	—	EMG2+	4
	Yellow	EMGIN	5
	Yellow	EMGOUT	6

Wiring	Color	Signal	No.
AWG24	Yellow	ENB1-	7
	Yellow	ENB1+	8
	—	ENB2-	9
	—	ENB2+	10
	Yellow	ENBIN	11
	Yellow	ENBOUT	12

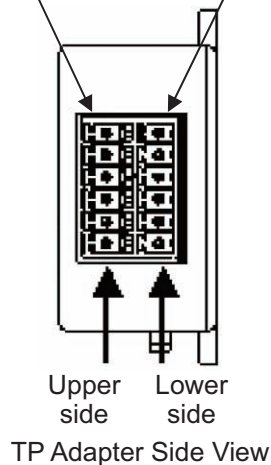

3) Connection of dummy plug of TP adapter  
Always plug in a dummy plug (DP-4S).

4) Enable function\*  
If you are using the enable function, set it to Enable using the controller parameter.  
Parameter No.42 Enable function  
0 ... Enable  
1 ... Disable [Default setting at shipment]

\* Enable function : It is the function to monitor the status of the signal (safety switch, dead man's switch on teaching pendant, etc.) to permit the devices to operate.



[3] Examples of Safety Circuits  
 1) In case of category 1

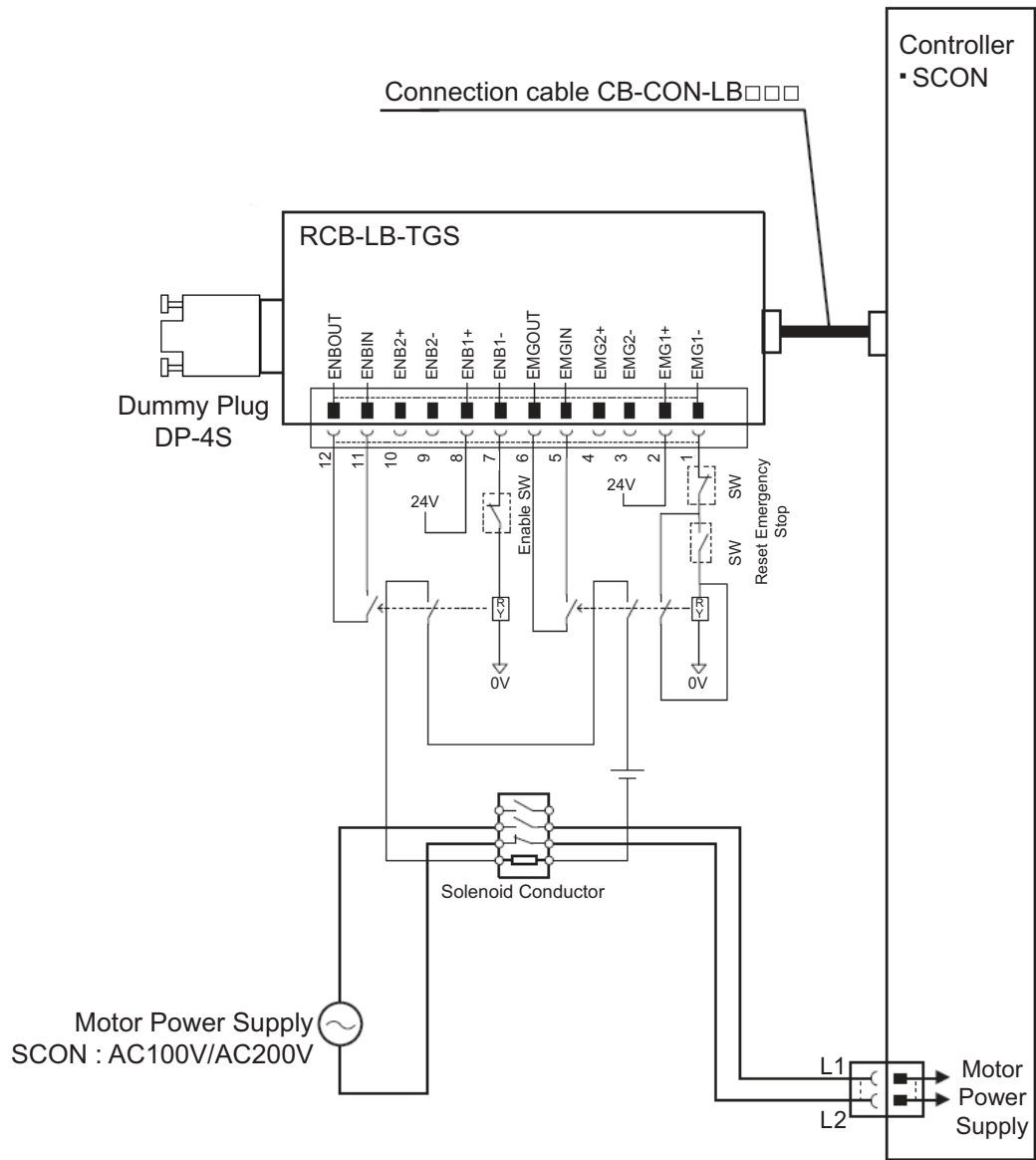

• Detailed category 1 circuit example

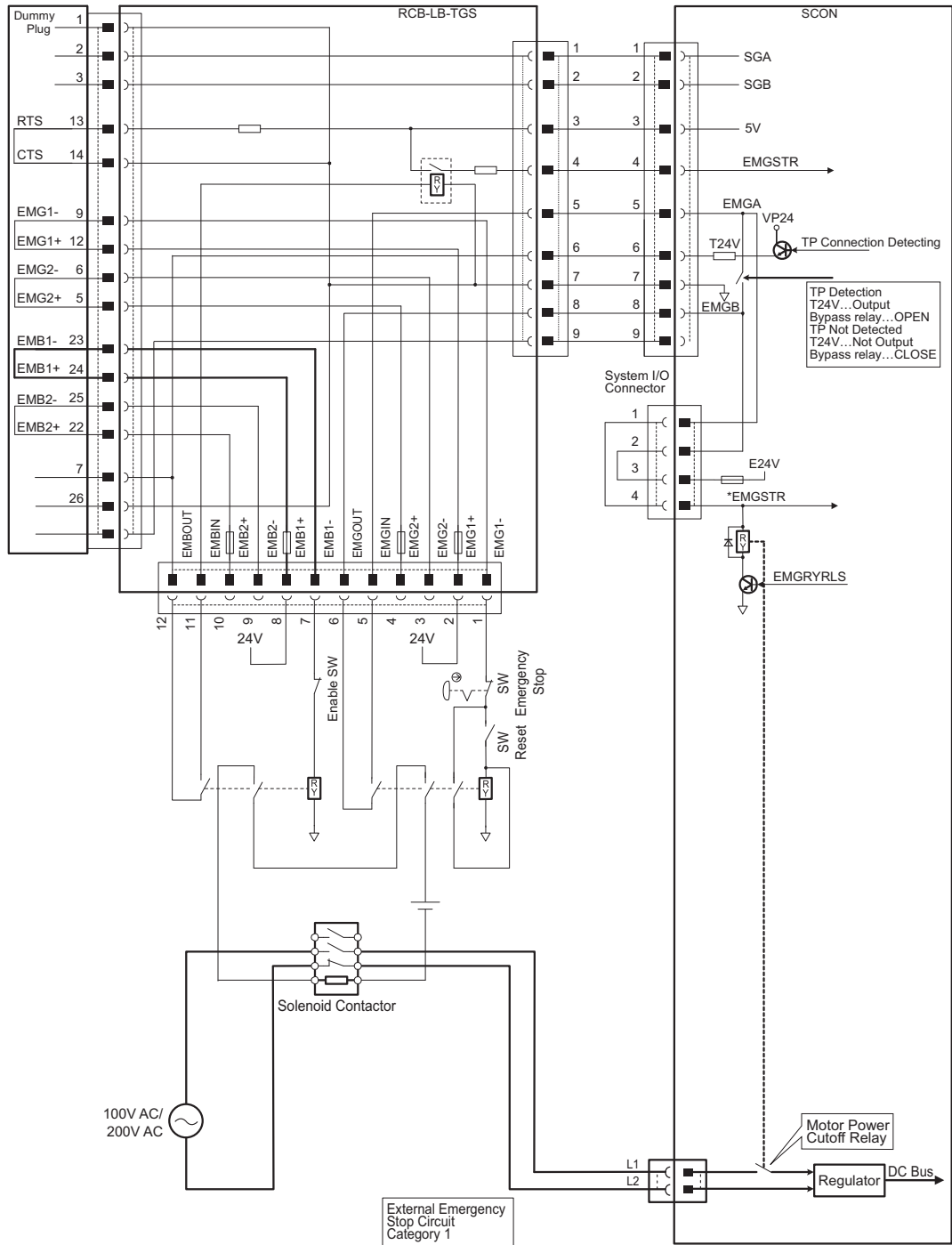

2) In case of category 2

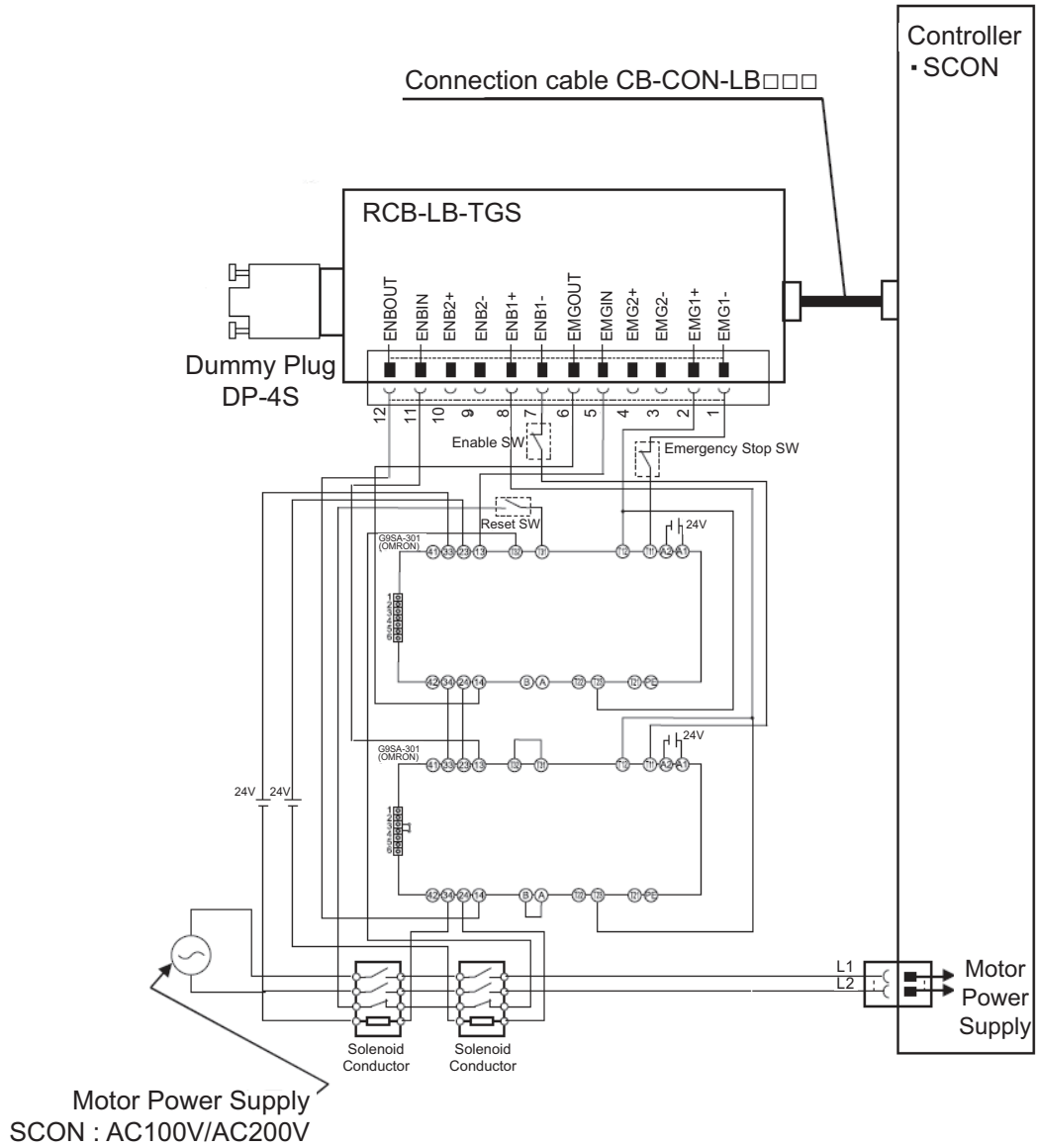

• Detailed category 2 circuit example

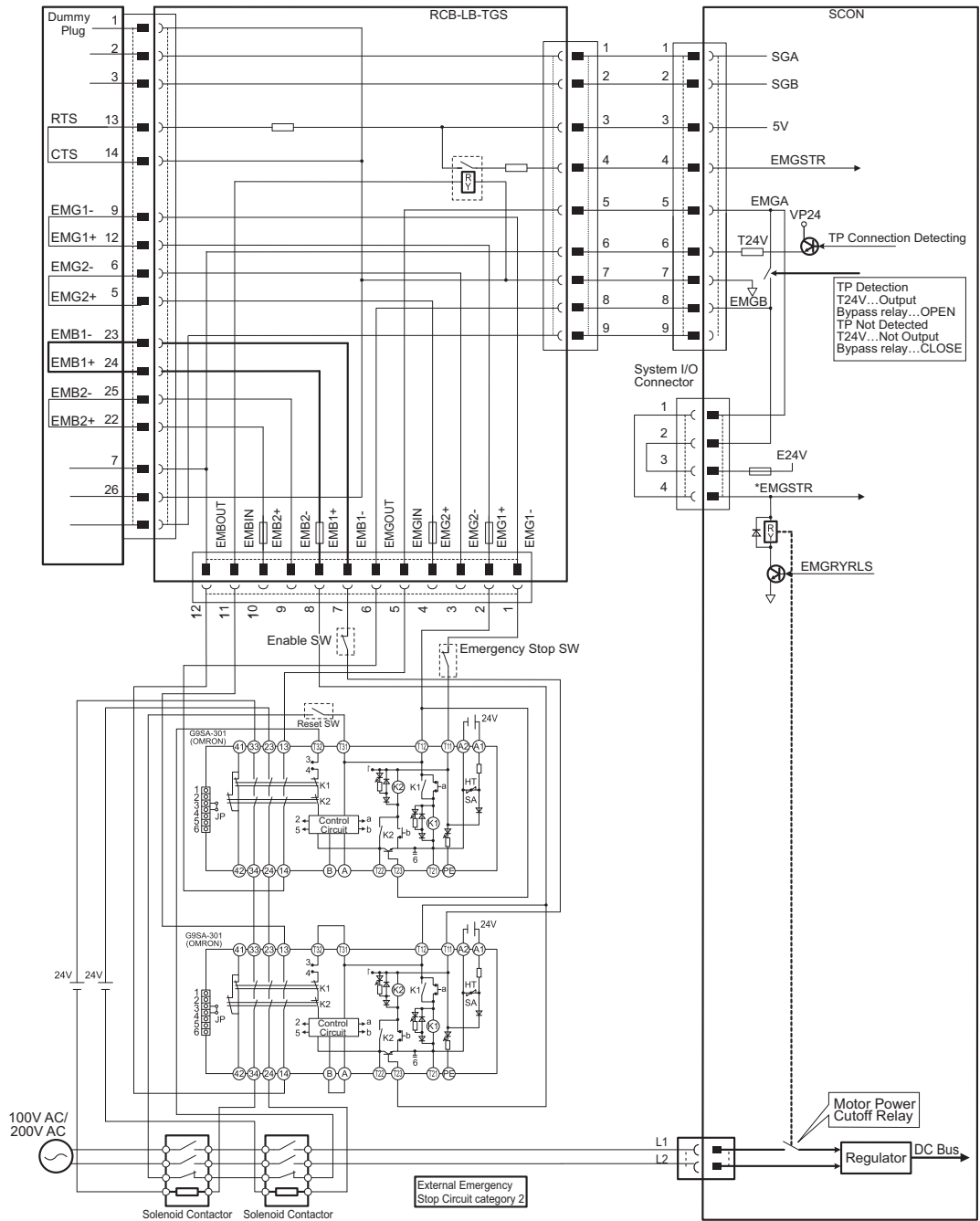

3) In case of category 3 or 4

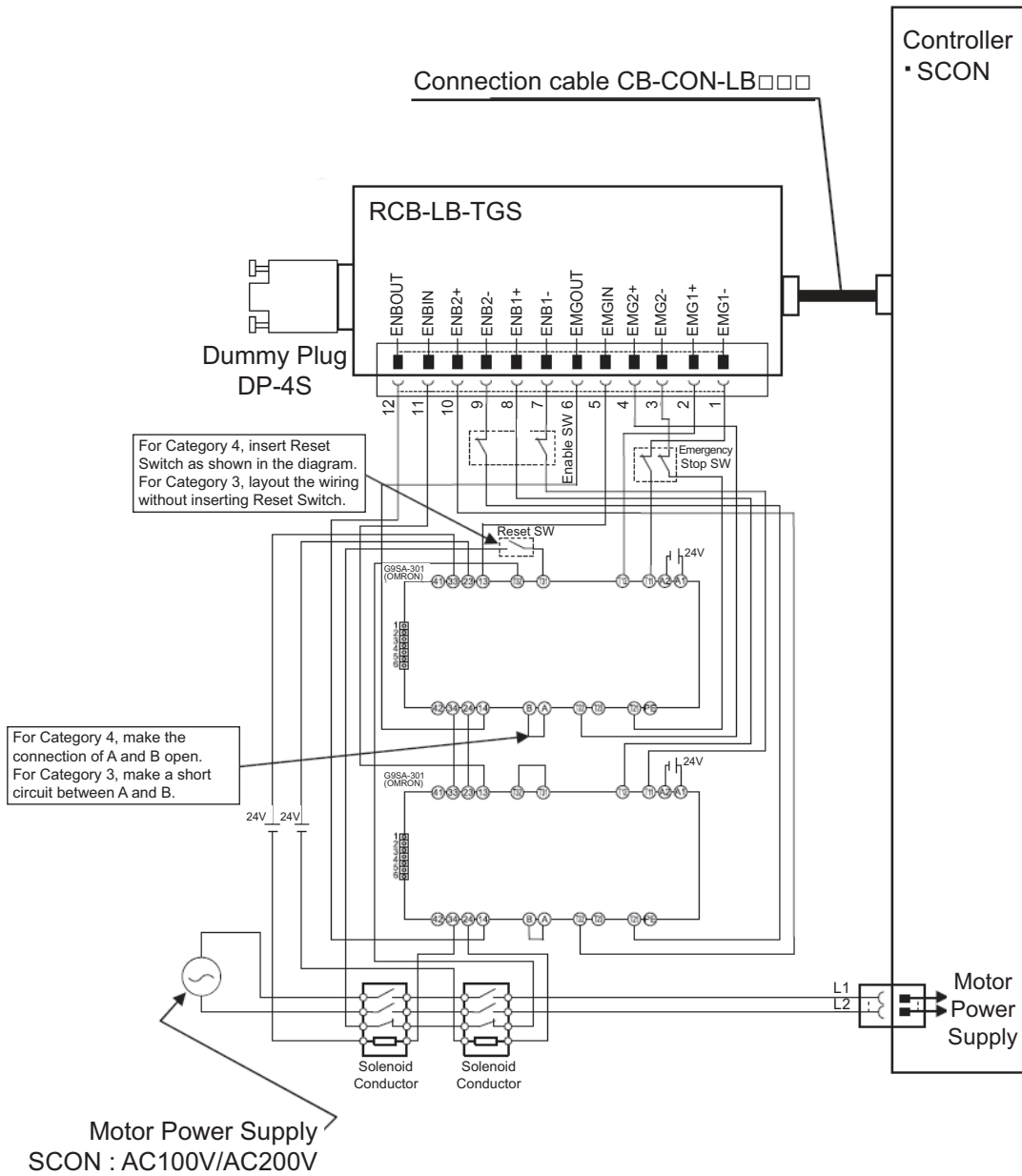

• Detailed category 3 or 4 circuit example

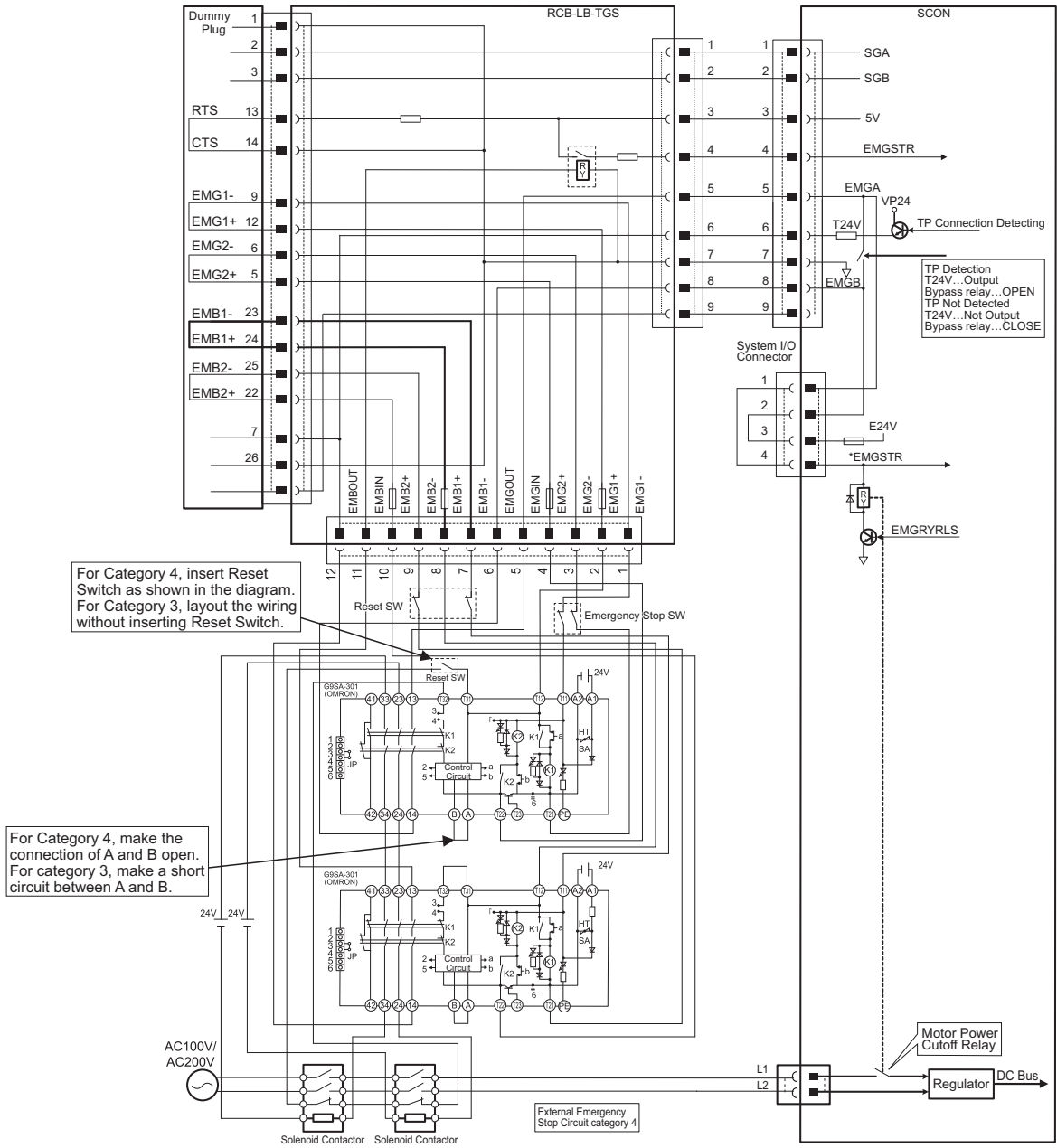

[4] TP Adapter and Related Components  
 1) TP adapter external dimensions

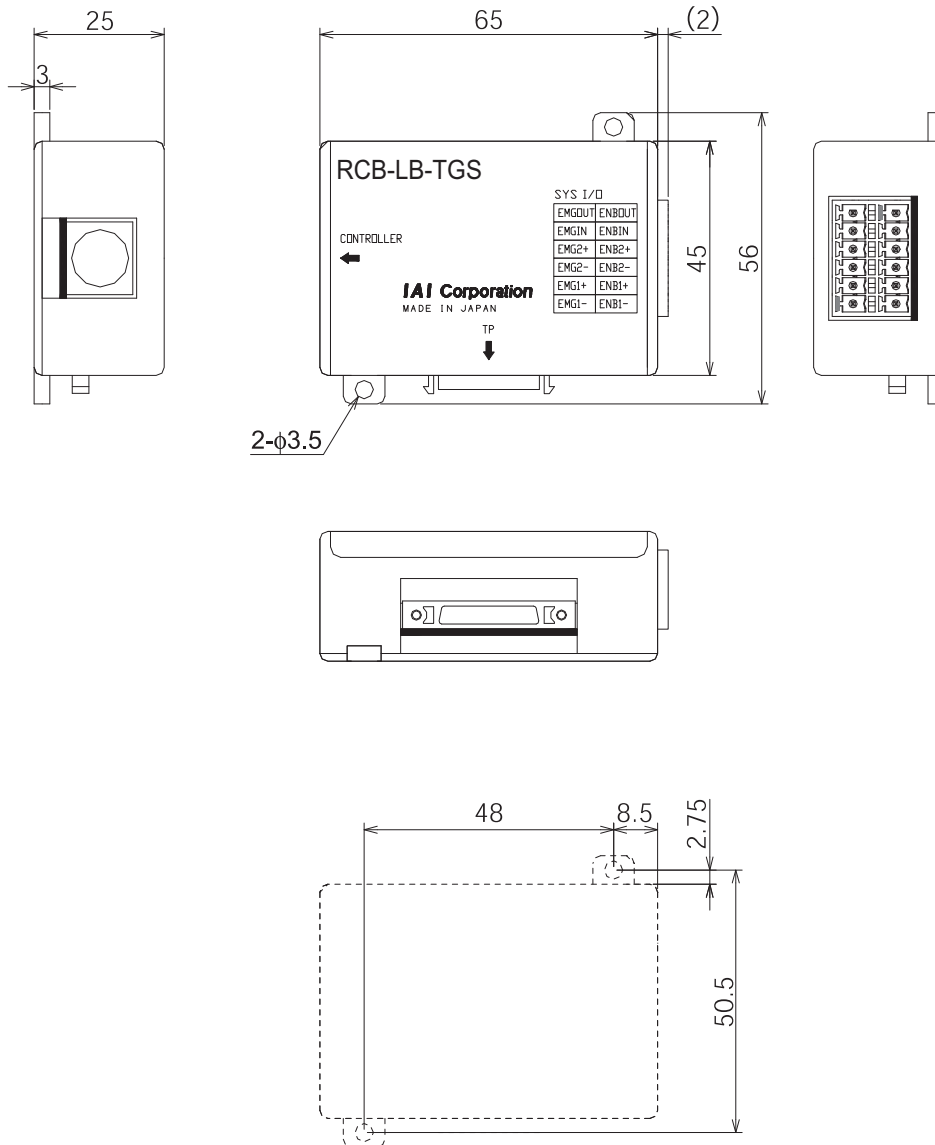

## 2) Connection Cable

- Controller/TP Adaptor Connection Cable

Use this cable to connect the controller and TP adapter (RCB-LB-TGS).

Model : CB-CON-LB005 (standard cable length : 0.5m)

Maximum cable length : 2.0m



CN1			CB-CON-LB □□□	CN2		
Color	Signal	No.		No.	Signal	Color
Brown	SGA	1	—————	1	SGA	Brown
Yellow	SGB	2	—————	2	SGB	Yellow
Red	5V	3	—————	3	5V	Red
Orange	EMGS	4	—————	4	EMGS	Orange
Blue	EMGA	5	—————	5	EMGA	Blue
Green	24V	6	—————	6	24V	Green
Purple	GND	7	—————	7	GND	Purple
Gray	EMGB	8	—————	8	EMGB	Gray
Shield	FG		—————	FG	Shield	

8PIN MIN DIN Connector (mold casting)  
 Contact : MD-SP2240 (J.S.T. Mfg.) ×8  
 Metal shell : MD-PS8T (J.S.T. Mfg.)  
 Housing A : MD-PI8A (J.S.T. Mfg.)  
 Housing B : MD-PI8B (J.S.T. Mfg.)  
 Cover : MD-PCC8T-S2 (J.S.T. Mfg.)

8PIN MIN DIN Connector (mold casting)  
 Contact : MD-SP2240 (J.S.T. Mfg.) ×8  
 Metal shell : MD-PS8T (J.S.T. Mfg.)  
 Housing A : MD-PI8A (J.S.T. Mfg.)  
 Housing B : MD-PI8B (J.S.T. Mfg.)  
 Cover : MD-PCC8T-S2 (J.S.T. Mfg.)



3) Dummy plug

Connect a dummy plug to the teaching pendant connecting connector.  
 Make sure to connect a dummy plug if the AUTO mode is specified.  
 Without the connection, it will be the emergency stop condition.  
 Model : DP-4S

DP-4S



Plug : HDR-E26MAG1+

Signal	No.
GND	1
EMGS	2
VCC	3
DTR	4
EMGOUT2	5
EMGIN2	6
NC	7
RSVCC	8
EMGIN1	9
NC	10
NC	11
EMGOUT1	12
RTS	13
CTS (GND)	14
TXD	15
RXD	16
DSR	17
NC	18
NC	19
RSVTBX1	20
RSVTBX2	21
ENBVCC2	22
ENBTBX1	23
ENBVCC1	24
ENBTBX2	25
GND	26

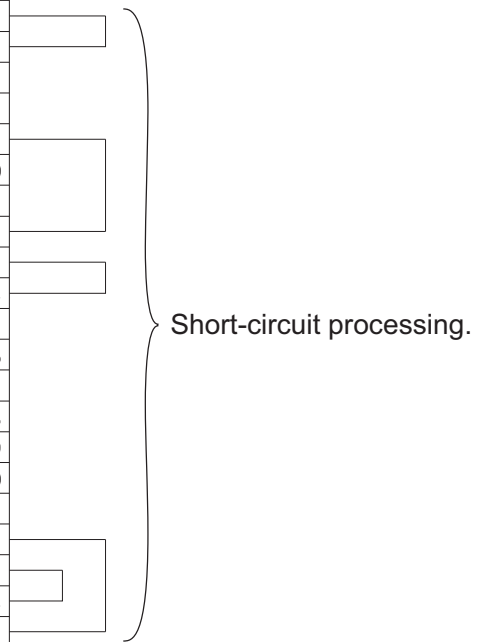

### 9.3 Maintenance

These parts below have production life. Shown below is the reference.

Item	Life	Specification
Electrolytic capacitor	5 years	0 to 40°C
Backup capacitor for calendar feature	5 years	When repeated to conduct for 12H in 40°C environment and cut for 12H in 20°C environment
Driving source cutoff relay (There is no CGB type)	25,000 times	It highly depends on how to use. [Refer to 8. Handling of Built-in Drive Cutoff Relay and Cautions in Caution in Handling]

## 9.4 List of Specifications of Connectable Actuators

### 9.4.1 List of Specifications for Actuator Operation Conditions

Specifications described in the specification list are limited to the information required to set operation conditions and parameters. For other detailed specifications, refer to brochures and Instruction Manuals of actuators.

Actuator Series	Type	Motor Output [W]	No. of Encoder Pluses	Lead [mm]	Oriented Direction	Maximum Speed [mm/s]	Maximum Acceleration/Deceleration Speed [G]	Minimum Pressing Force [N]	Maximum Pressing Force [N]	Rated Pressing Speed [mm/s]
RCS2 (Rod Type)	RA13R	750	16384	2.5	Horizontal/Vertical	85 (at 50st) 120 (at to 100st) 125 (at to 200st)	0.02	1000	9800	10
				1.25		62				
RCS3 (Rod Type)	RA4R	30	16384	2.5	Horizontal/Vertical	125	0.5	20	200	10
	RA6R	60	16384	1.5		75	0.3	60	600	
	RA7R	100	16384	2		100	0.3	200	1200	
	RA8R	200	16384	2.5		125	0.3	200	2000	
	RA10R	300	16384	2.5		125	0.3	600	6000	
	RA15R	3300	16384	3.6		240	0.1	3000	30000	
	RA20R	3000	16384	4.0		220	0.1	5000	50000	

(Note) The minimum velocity for each actuator should be 1mm/s. Do not attempt to set a value less than 1mm/s.

### 9.4.2 Specifications and Limitations in Pressing Operation

#### [1] Pressing Force and Current-Limiting Value

**⚠ Caution:**

- The relation between pressing force and current limit value is shown with reference values at the rating pressing speed (set at shipment).
- Apply a pressing force larger than the minimum pressing force to the actuator. If not, the pressing force can be unstable.
- If it becomes necessary to change the pressing speed, contact us. The positioning speed, a operation condition, should not be set to be less than the pressing speed. Failure to follow this causes the pressing speed to be the setting speed, which cannot bring proper pressing force.

- Figure of mutual relation between pressing force and current limit value of RCS2-RA13R (-LC)

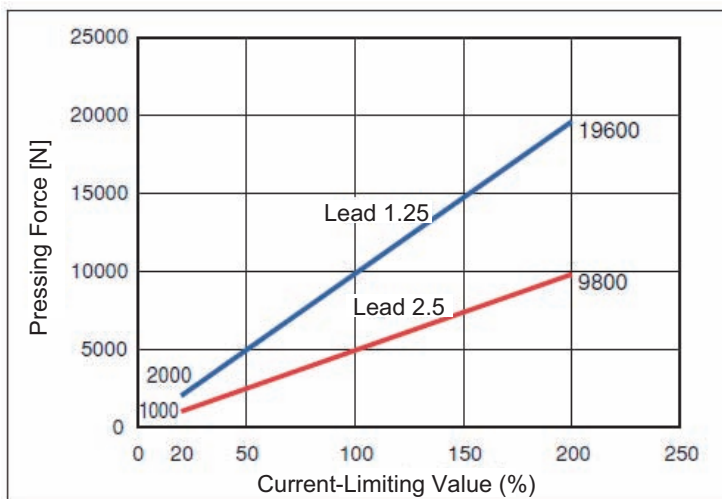

- Figure of mutual relation between pressing force and current limit value of RCS3-RA4R-LC

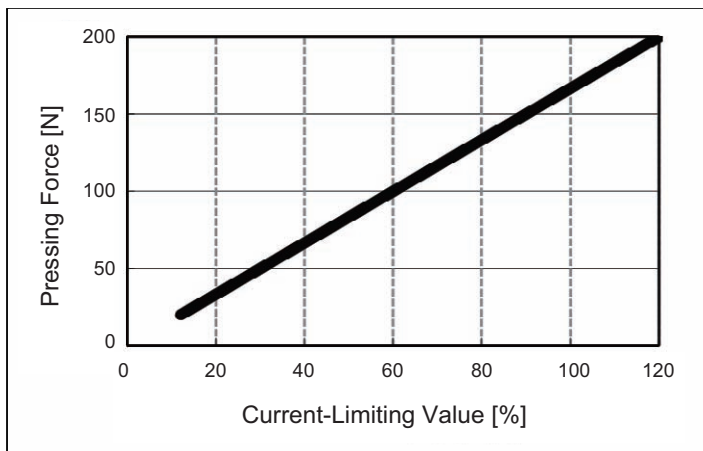

- Figure of mutual relation between pressing force and current limit value of RCS3-RA6R-LC

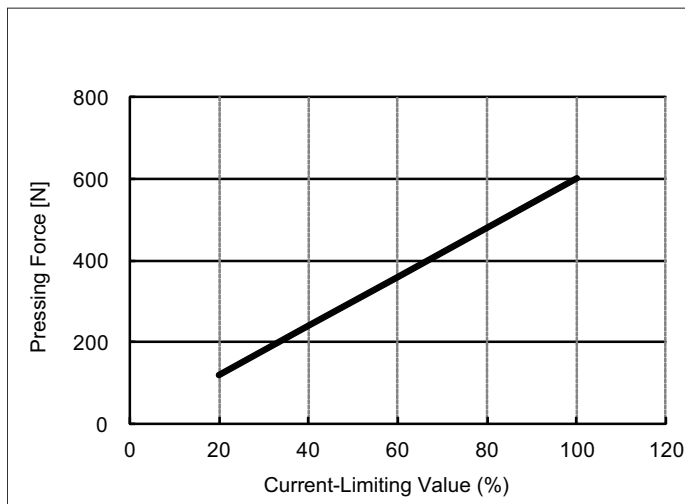

- Figure of mutual relation between pressing force and current limit value of RCS3-RA7R-LC

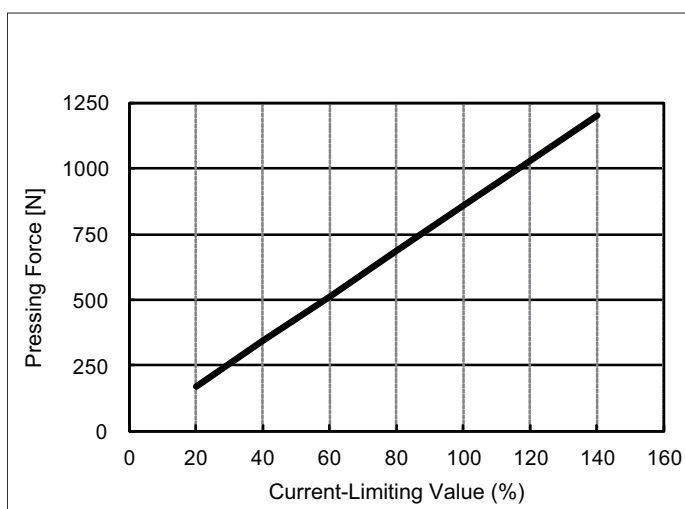

- Figure of mutual relation between pressing force and current limit value of RCS3-RA8R-LC

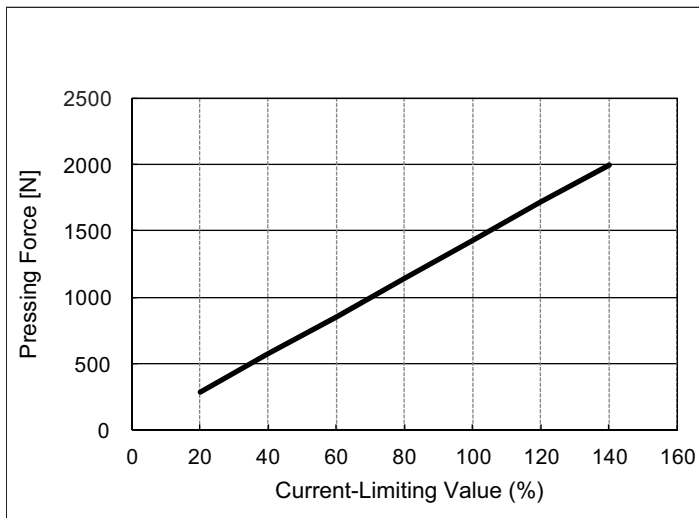

- Figure of mutual relation between pressing force and current limit value of RCS3-RA10R-LC

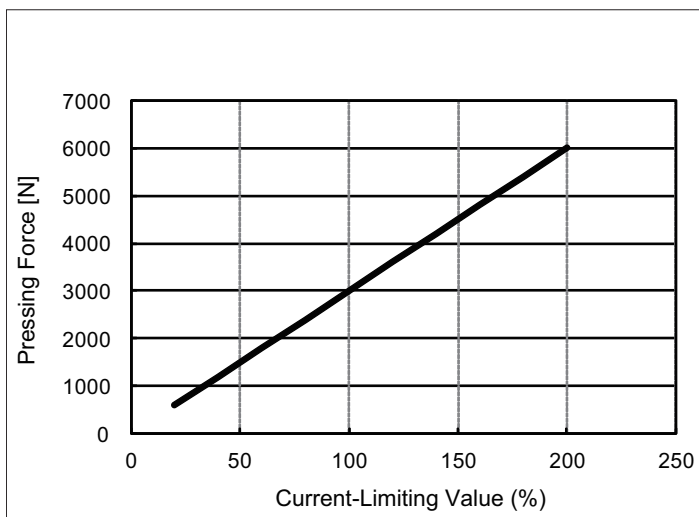

- Figure of mutual relation between pressing force and current limit value of RCS3-RA15R-LC

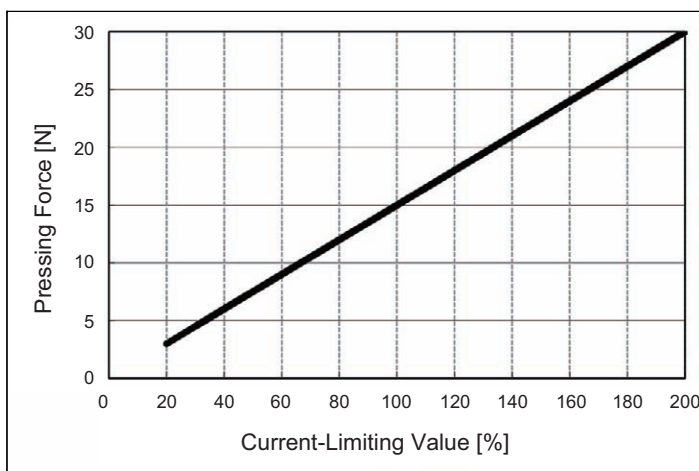

- Figure of mutual relation between pressing force and current limit value of RCS3-RA20R-LC

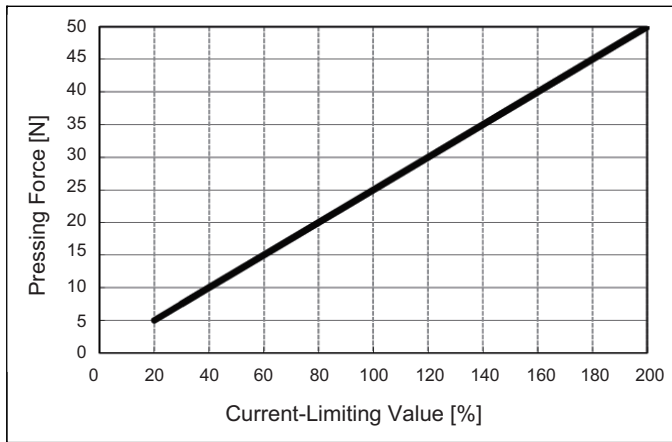

[2] Limitation in Operation

Keep following three conditions for operation.

- Condition 1. Pressing time should be within the determined duration.  
(e.g.: The current and time for pressing is restricted for RCS2-RA13R,  
RCS3-RA15R, RCS3-RA20R.)
- Condition 2. The continuous operation thrust in one cycle should be within the rated thrust of each actuator.
- Condition 3. There should be one time of pressing operation in one cycle.  
Refer to each actuator instruction manual for the details.

## Chapter 10 Warranty

### 10.1 Warranty Period

One of the following periods, whichever is shorter:

- 18 months after shipment from our factory
- 12 months after delivery to a specified location

### 10.2 Scope of the Warranty

Our products are covered by warranty when all of the following conditions are met. Faulty products covered by warranty will be replaced or repaired free of charge:

- (1) The breakdown or problem in question pertains to our product as delivered by us or our authorized dealer.
- (2) The breakdown or problem in question occurred during the warranty period.
- (3) The breakdown or problem in question occurred while the product was in use for an appropriate purpose under the conditions and environment of use specified in the instruction manual and catalog.
- (4) The breakdown or problem in question was caused by a specification defect or problem, or by the poor quality of our product.

Note that breakdowns due to any of the following reasons are excluded from the scope of warranty:

- [1] Anything other than our product
- [2] Modification or repair performed by a party other than us (unless we have approved such modification or repair)
- [3] Anything that could not be easily predicted with the level of science and technology available at the time of shipment from our company
- [4] A natural disaster, man-made disaster, incident or accident for which we are not liable
- [5] Natural fading of paint or other symptoms of aging
- [6] Wear, depletion or other expected result of use
- [7] Operation noise, vibration or other subjective sensation not affecting function or maintenance

Note that the warranty only covers our product as delivered and that any secondary loss arising from a breakdown of our product is excluded from the scope of warranty.

### 10.3 Honoring the Warranty

As a rule, the product must be brought to us for repair under warranty.

### 10.4 Limited Liability

- (1) We shall assume no liability for any special damage, consequential loss or passive loss such as a loss of expected profit arising from or in connection with our product.
- (2) We shall not be liable for any program or control method created by the customer to operate our product or for the result of such program or control method.

## 10.5 Conditions of Conformance with Applicable Standards/Regulations, Etc., and Applications

- (1) If our product is combined with another product or any system, device, etc., used by the customer, the customer must first check the applicable standards, regulations and/or rules. The customer is also responsible for confirming that such combination with our product conforms to the applicable standards, etc. In such a case we will not be liable for the conformance of our product with the applicable standards, etc.
- (2) Our product is for general industrial use. It is not intended or designed for the applications specified below, which require a high level of safety. Accordingly, as a rule our product cannot be used in these applications. Contact us if you must use our product for any of these applications:
  - [1] Medical equipment pertaining to maintenance or management of human life or health
  - [2] A mechanism or mechanical equipment intended to move or transport people (such as a vehicle, railway facility or aviation facility)
  - [3] Important safety parts of mechanical equipment (such as safety devices)
  - [4] Equipment used to handle cultural assets, art or other irreplaceable items
- (3) Contact us at the earliest opportunity if our product is to be used in any condition or environment that differs from what is specified in the catalog or instruction manual.

## 10.6 Other Items Excluded from Warranty

The price of the product delivered to you does not include expenses associated with programming, the dispatch of engineers, etc. Accordingly, a separate fee will be charged in the following cases even during the warranty period:

- [1] Guidance for installation/adjustment and witnessing of test operation
- [2] Maintenance and inspection
- [3] Technical guidance and education on operating/wiring methods, etc.
- [4] Technical guidance and education on programming and other items related to programs



## Change History

Revision Date	Revision Description
2015.08	First Edition
2015.11	Edition1B P12 Deleted ⑨ and ⑩ at Note to “Name for Each Parts and Their Functions”
2016.02	Second Edition The contents of the 3000 to 3300W type added
2016.04	Third Edition The Transcription of the LC-F type added
2016.07	Fourth Edition Force Control Position Stop 2 mode added
2016.10	Fifth Edition Change made to input available range for electric gear setting (from V0006) Statement revised for regenerative unit Details added for drive cutoff contact output Statement added for 2CH Record Mode in monitoring cycle Note added for cause and treatment of alarm codes 0A3 and 0A4 Correction made to statement
2016.11	5B Edition Contents revised in UL description Available range for input changed in electronic gear setting, correction made to description Connector pin numbers corrected for TP adapter and I/O connectors
2017.11	5C Edition 1.5.4 The transcription of the temperature drift deleted
2018.01	5D Edition 2.1.2 [5], 2.3.2 [5] Correction made to ON/OFF status of *ALML Signal 2.3.2 [3] Correction made to cable numbers on brake power supply connector and connector model codes added 2.4.6 Number of regenerative units corrected 3.3.3.2 Correction made to timing chart in Example of Operation Got applicable for TB-02 and TB-03
2018.02	5E Edition Applicable cable size revised 2.2.5, 2.4.5 Description added for pin numbers on connector soldering side 3.1.3.3, 9.4.1 Change made to the minimum velocity and note added







## ***IAI Corporation***

Head Office: 577-1 Obane Shimizu-KU Shizuoka City Shizuoka 424-0103, Japan  
TEL +81-54-364-5105 FAX +81-54-364-2589  
website: [www.iai-robot.co.jp/](http://www.iai-robot.co.jp/)

Technical Support available in USA, Europe and China

## ***IAI America, Inc.***

Head Office: 2690 W. 237th Street, Torrance, CA 90505  
TEL (310) 891-6015 FAX (310) 891-0815  
Chicago Office: 110 East State Parkway, Schaumburg, IL 60173  
TEL (847) 908-1400 FAX (847) 908-1399  
Atlanta Office: 1220 Kennestone Circle, Suite 108, Marietta, GA 30066  
TEL (678) 354-9470 FAX (678) 354-9471  
website: [www.intelligentactuator.com](http://www.intelligentactuator.com)

## ***IAI Industrieroboter GmbH***

Ober der Röth 4, D-65824 Schwalbach am Taunus, Germany  
TEL 06196-88950 FAX 06196-889524

## ***IAI (Shanghai) Co., Ltd.***

SHANGHAI JIAHUA BUSINESS CENTER A8-303, 808, Hongqiao Rd. Shanghai 200030, China  
TEL 021-6448-4753 FAX 021-6448-3992  
website: [www.iai-robot.com](http://www.iai-robot.com)

## ***IAI Robot (Thailand) Co., Ltd.***

825, PhairojKijja Tower 12th Floor, Bangna-Trad RD., Bangna, Bangkok 10260, Thailand  
TEL +66-2-361-4458 FAX +66-2-361-4456