

# IK2: 2-axis Cartesian Robot

- RCP2: 24V Stepper
- RCS2: 230V Servo

# ROBO Cylinder IK Series Catalog



# ROBO Cylinder IK Series

## IK Series: Components

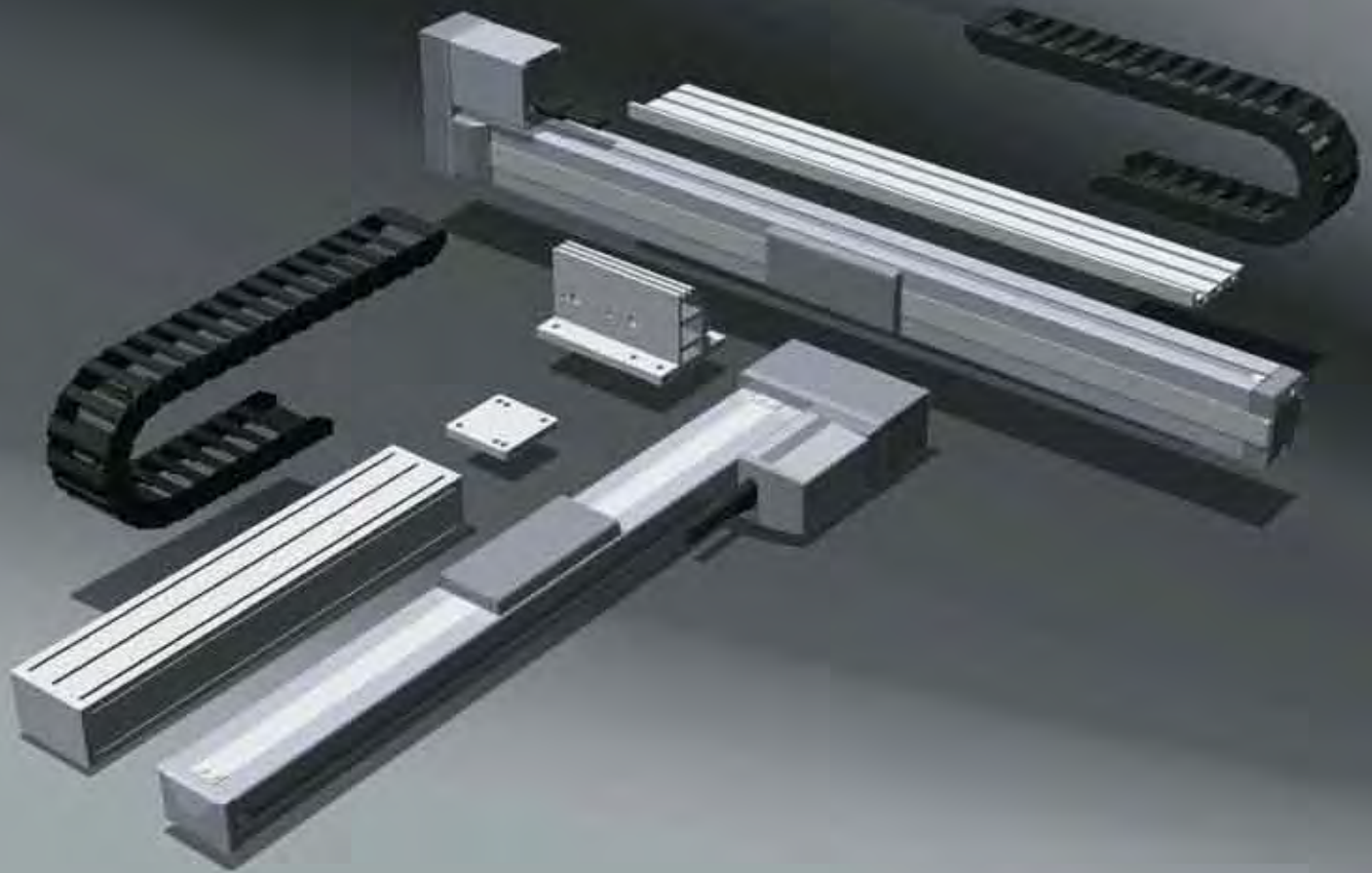

### 1. Wide Variation

The engineers at IAI have worked extensively to produce the highest quality products at affordable prices. The new IK Series lineup offers many variations and can be easily integrated and prepared to your specific needs.

### 2. Motor Options

The IK Series is offered in both pulse and servo motors. Choose the pulse motor for applications requiring high thrust at low speeds. Choose the servo motor for applications requiring constant thrust regardless of the operating speed.

### 3. Easy Assembly

The ROBO Cylinder IK Series multi-axes kit includes everything needed for fast and easy assembly.

Components



Assembled



# Multi-Axes Systems

**IK Series: Assembled**



## 4. High Functionality

Combined with the PCON/PSEL/SCON/SSEL/XSEL controllers, complex programming is made easy.



## 5. Quality and Innovation

We at IAI are always working to offer high quality and innovative solutions tailored for your specific application. Whenever you need support, IAI's experienced teams of technical support engineers are available to help you diagnose and troubleshoot IAI products. When you require innovative and high quality robots, excellent service and support for your unique needs, demand IAI!





# Wide-ranging Lineup Lineup of IK Series

## Combinations

### XYB (XY, base mount)

Page

IK2-PXBD Series ...13~  
IK2-SXBD Series ...43~

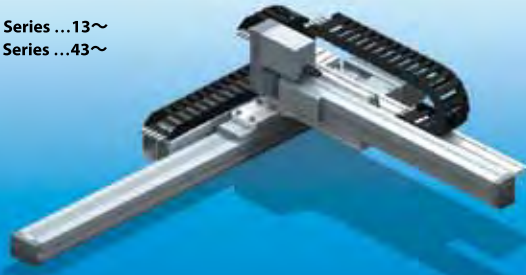

Page

IK2-PXBC Series ...21~  
IK2-SXBC Series ...51~



#### •IK2-PXBD Series •IK2-SXBD Series

		Maximum X-axis stroke	Maximum Y-axis stroke	Load capacity at maximum Y-axis stroke
Single-slider	Y high-speed type	600mm	200mm	2.5kg
	Y medium-speed type	600mm	200mm	5.0kg
Double-slider	Y high-speed type	450mm	400mm	2.0kg
	Y medium-speed type	450mm	400mm	4.0kg

#### •IK2-PXBC Series •IK2-SXBC Series

		Maximum X-axis stroke	Maximum Y-axis stroke	Load capacity at maximum Y-axis stroke
Single-slider	Y high-speed type	600mm	200mm	3.0kg
	Y medium-speed type	600mm	200mm	6.0kg
Double-slider	Y high-speed type	450mm	400mm	3.0kg
	Y medium-speed type	450mm	400mm	6.0kg

### XZ (Upright type)

Page

IK2-PXZB Series ...37~  
IK2-SXZB Series ...75~



#### •IK2-PXZB Series •IK2-SXZB Series

		Maximum X-axis stroke	Maximum Z-axis stroke	Load capacity at maximum Y-axis stroke
Single-slider	X high-speed/Z high-speed type	1,000mm	250mm	1.5kg
	X high-speed/Z medium-speed type	1,000mm	250mm	2.5kg
	X high-speed/Z low-speed type	1,000mm	250mm	3.0kg
Double-slider	X high-speed/Z high-speed type	800mm	300mm	1.5kg
	X high-speed/Z medium-speed type	800mm	300mm	3.0kg
	X high-speed/Z low-speed type	800mm	300mm	5.5kg

### YZB (Cross type, base mount)

Page

IK2-PYBB Series ...41~  
IK2-SYBB Series ...79~



#### •IK2-PYBB Series •IK2-SYBB Series

		Maximum X-axis stroke	Maximum Z-axis stroke	Load capacity at maximum Y-axis stroke
Single-slider	X high-speed/Z high-speed type	1,000mm	300mm	1.5kg
	X high-speed/Z medium-speed type	1,000mm	300mm	3.0kg
	X high-speed/Z low-speed type	1,000mm	300mm	5.5kg



**IK2-P Series / IK3-P Series** ROBO Cylinder RCP2 combinations based on pulse motor

**IK2-S Series / IK3-S Series** ROBO Cylinder RCS2 combinations based on servo motor

Page

IK2-PXBB Series ...29~  
IK2-SXBB Series ...59~

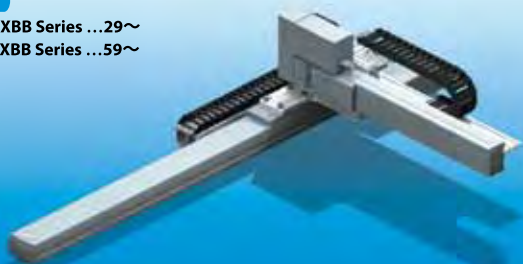

Page

IK2-SXBA Series ...67~

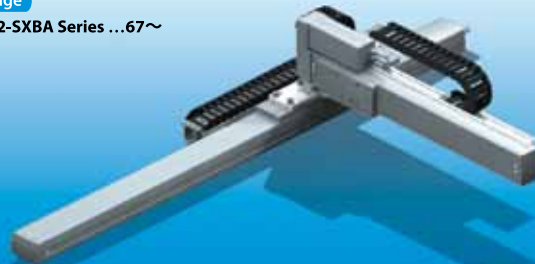

**•IK2-PXBB Series    •IK2-SXBB Series**

		Maximum X-axis stroke	Maximum Y-axis stroke	Load capacity at maximum Y-axis stroke
Single-slider	High-speed type	1,000mm	300mm	6.0kg
	Medium-speed type	1,000mm	300mm	8.0kg
Double-slider	High-speed type	800mm	400mm	5.5kg
	Medium-speed type	800mm	400mm	10.5kg

**•IK2-SXBA Series**

		Maximum X-axis stroke	Maximum Y-axis stroke	Load capacity at maximum Y-axis stroke
Single-slider	High-speed type	1,000mm	350mm	7.0kg
	Medium-speed type	1,000mm	200mm	12.5kg
Double-slider	High-speed type	800mm	400mm	10.0kg
	Medium-speed type	800mm	400mm	11.5kg

# IK Series

The IK Series is a set that includes the following components needed to assemble the cartesian robot.

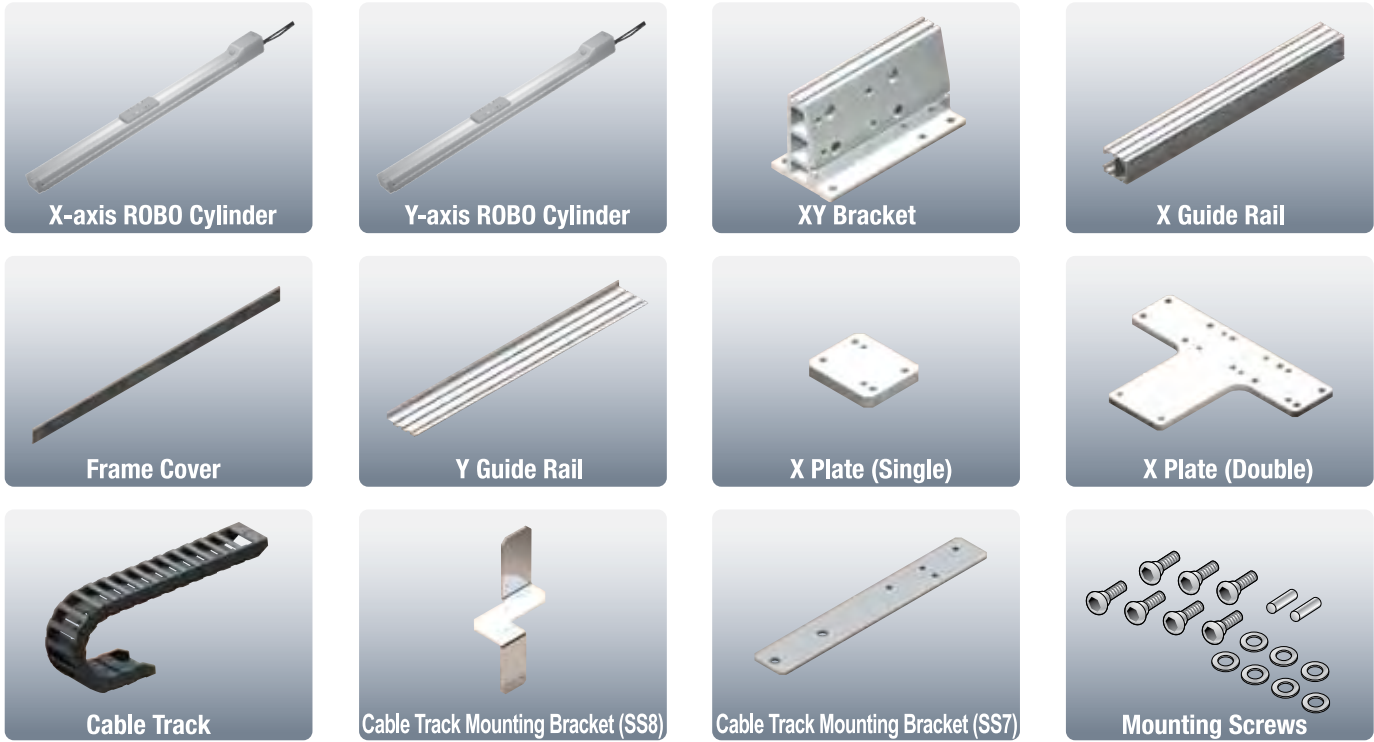

Note: The above images are provided for reference purposes only. The actual components may vary depending on the combination type, direction, etc.

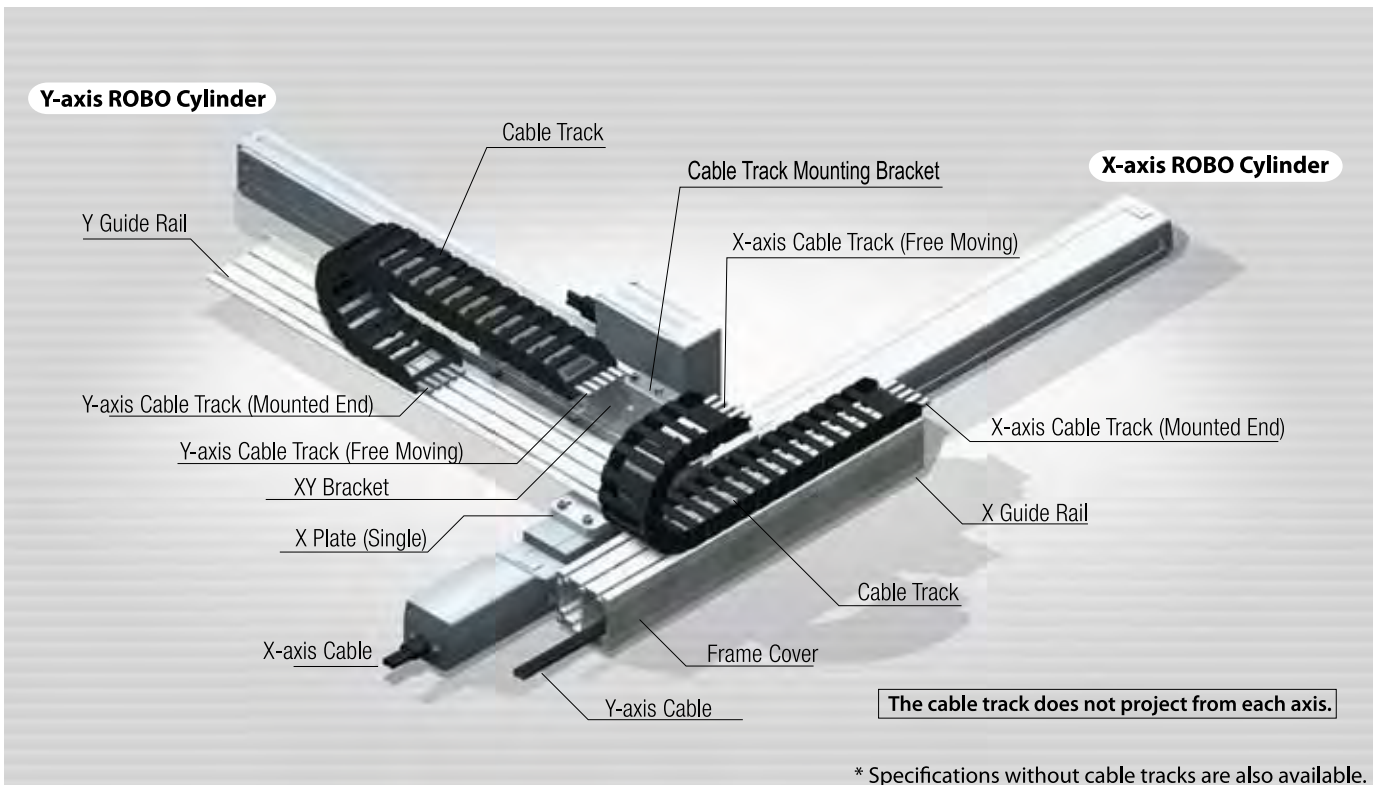

# Load Capacity Graphs for XYB Combinations

[IK2-PXBD/IK2-SXBD]

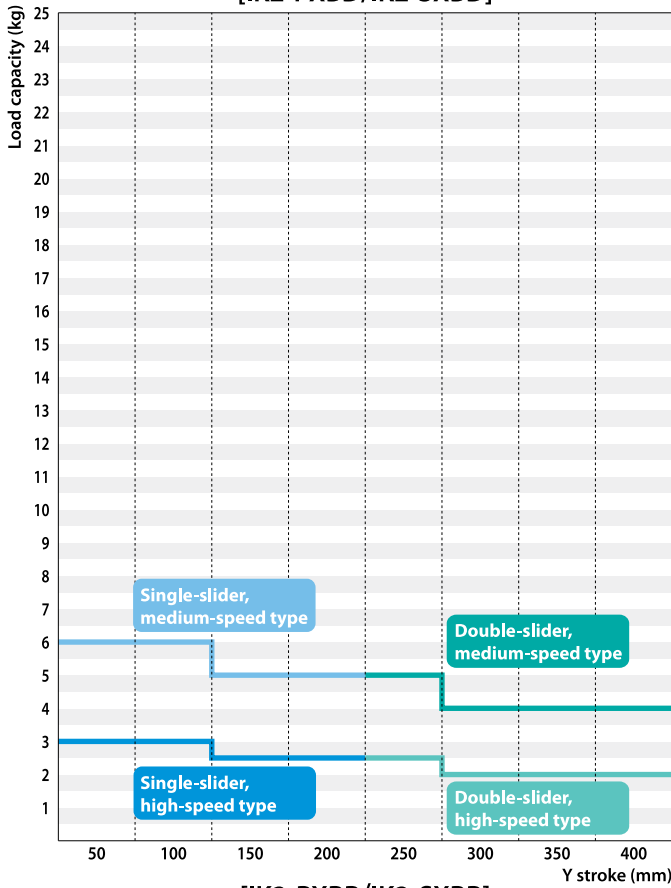

[IK2-PXBC/IK2-SXBC]

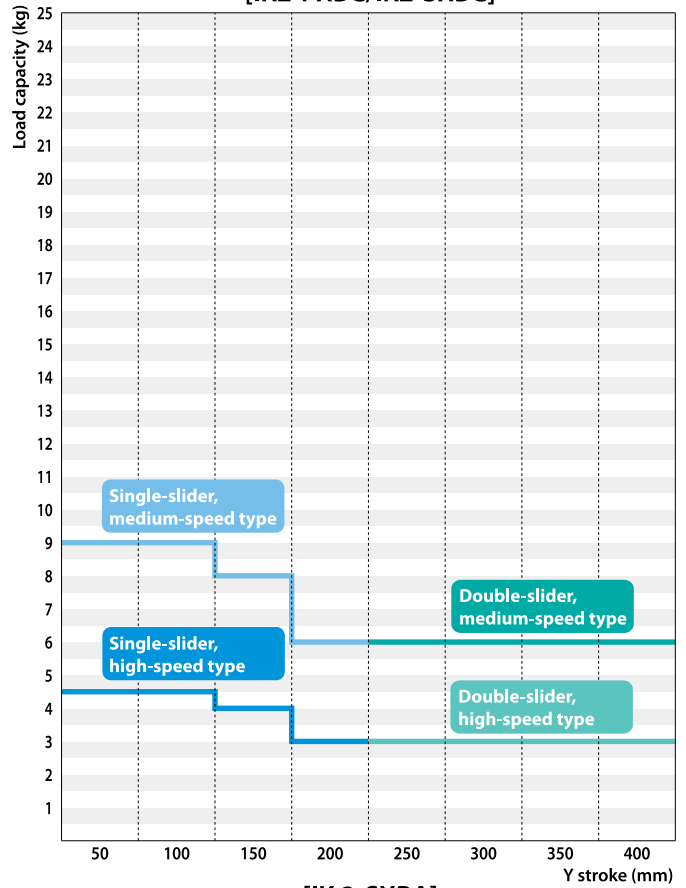

[IK2-PXBB/IK2-SXBB]

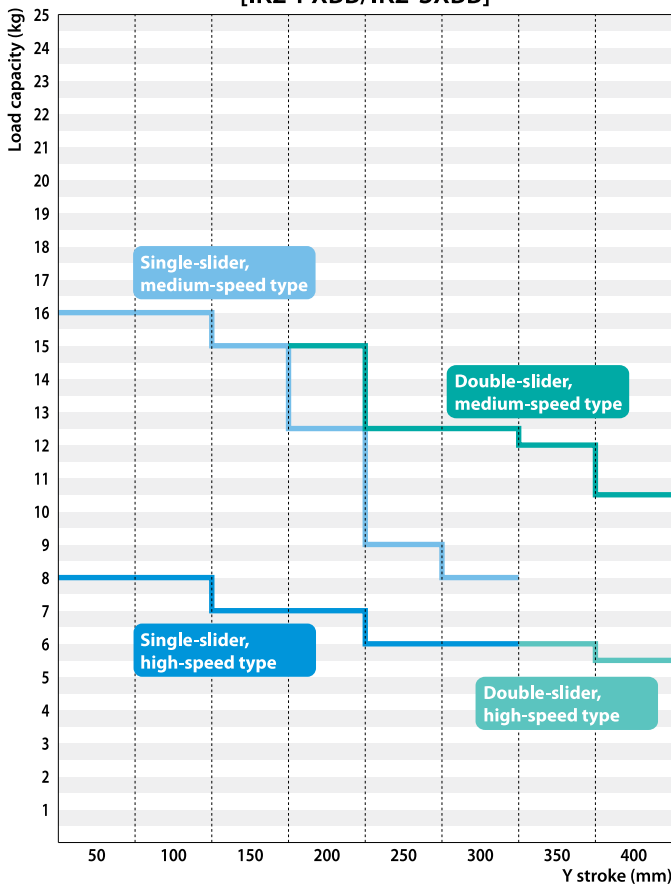

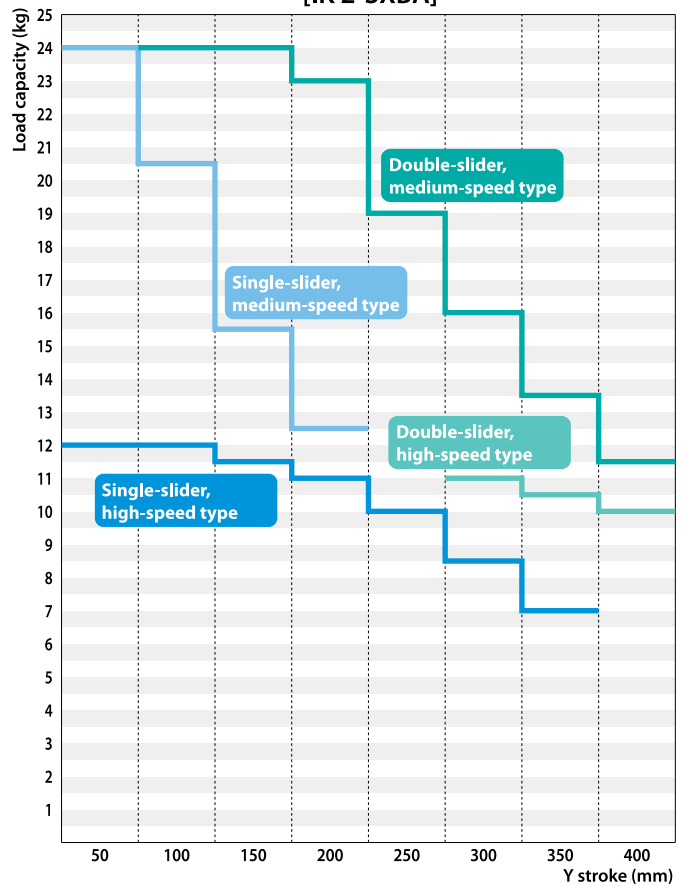

[IK 2-SXBA]





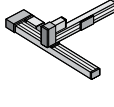
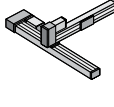
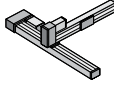
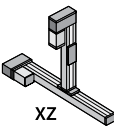

# Combination Unit List for IK Series

**RCP2** Combination Unit List for 2-axis Configuration (XYB) (□ in the model names indicates a value from 1 to 4 specifying the combination direction. For the combination directions, refer to P.10.)

Page	Combination model	Combined shape	Type	Axis 1				Axis 2									
				Motor size	Lead (mm)	Maximum speed (mm/sec)	Stroke (mm)	Type									
13	IK2-PXBD1□HHS		SS7R Reversed	42□	12	400	50-600	SA5R Reversed									
	IK2-PXBD1□HMS				12	350											
15	IK2-PXBD1□HHD		SS7R Reversed, double-slider		12	400	50-450										
	IK2-PXBD1□HMD				12	350											
17	IK2-PXBD2□HHS		SS7C Straight		12	400	50-600										
	IK2-PXBD2□HMS				12	350											
19	IK2-PXBD2□HHD		SS7C Straight, double-slider		12	400	50-450										
	IK2-PXBD2□HMD				12	350											
21	IK2-PXBC1□HHS				SS7R Reversed	56□	12			400	50-600	SA6R Reversed					
	IK2-PXBC1□HMS						12			250							
23	IK2-PXBC1□HHD				SS7R Reversed, double-slider		12			400	50-450						
	IK2-PXBC1□HMD						12			250							
25	IK2-PXBC2□HHS				SS7C Straight		12			400	50-600						
	IK2-PXBC2□HMS						12			250							
27	IK2-PXBC2□HHD				SS7C Straight, double-slider		12			400	50-450						
	IK2-PXBC2□HMD						12			250							
29	IK2-PXBB1□HHS						SS8R Reversed			56□	20			250	50-1000	SA7R Reversed	
	IK2-PXBB1□MMS	10		125													
31	IK2-PXBB1□HHD	SS8R Reversed, double-slider		20			250	50-800									
	IK2-PXBB1□MMD			10			125										
33	IK2-PXBB2□HHS	SS8C Straight		20			250	50-1000									
	IK2-PXBB2□MMS			10			125										
35	IK2-PXBB2□HHD	SS8C Straight, double-slider		20			250	50-800									
	IK2-PXBB2□MMD			10			125										
37	IK2-PXZB1□HHS			SS8R Reversed			56□	20	250		50-1000			SA7R Reversed			
	IK2-PXZB1□HMS		50-800														
39	IK2-PXZB1□HHD		SS8R Reversed, double-slider	50-800													
	IK2-PXZB1□HMD			50-800													
41	IK2-PYBB1□HHS			SS8R Reversed									50-1000				
	IK2-PYBB1□HMS												50-1000				
IK2-PYBB1□HLS	50-1000																

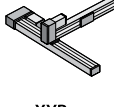
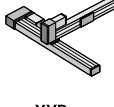
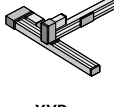
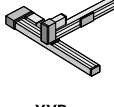
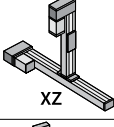
**RCS2** Combination Unit List for 2-axis Configuration (XYB) (□ in the model names indicates a value from 1 to 4 specifying the combination direction. For the combination directions, refer to P.10.)

Page	Combination model	Combined shape	Type	Axis 1				Axis 2									
				Motor output (W)	Lead (mm)	Maximum speed (mm/sec)	Stroke (mm)	Type									
43	IK2-SXBD1□HHS		SS7R Reversed	60	12	600	50-600	SA5R Reversed									
	IK2-SXBD1□HMS				12	600											
45	IK2-SXBD1□HHD		SS7R Reversed, double-slider		12	600	50-450										
	IK2-SXBD1□HMD				12	600											
47	IK2-SXBD2□HHS		SS7C Straight		12	600	50-600										
	IK2-SXBD2□HMS				12	600											
49	IK2-SXBD2□HHD		SS7C Straight, double-slider		12	600	50-450										
	IK2-SXBD2□HMD				12	600											
51	IK2-SXBC1□HHS				SS7R Reversed	100	12			600	50-600	SA6R Reversed					
	IK2-SXBC1□MMS						6			300							
53	IK2-SXBC1□HHD				SS7R Reversed, double-slider		12			600	50-450						
	IK2-SXBC1□MMD						6			300							
55	IK2-SXBC2□HHS				SS7C Straight		12			600	50-600						
	IK2-SXBC2□MMS						6			300							
57	IK2-SXBC2□HHD				SS7C Straight, double-slider		12			600	50-450						
	IK2-SXBC2□MMD						6			300							
59	IK2-SXBB1□HHS						SS8R (100W) Reversed			150	20			1000	50-1000	SA7R Reversed	
	IK2-SXBB1□MMS	10		500													
61	IK2-SXBB1□HHD	SS8R (100W) Reversed, double-slider		20			1000	50-800									
	IK2-SXBB1□MMD			10			500										
63	IK2-SXBB2□HHS	SS8C (100W) Straight		20			1000	50-1000									
	IK2-SXBB2□MMS			10			500										
65	IK2-SXBB2□HHD	SS8C (100W) Straight, double-slider		20			1000	50-800									
	IK2-SXBB2□MMD			10			500										
67	IK2-SXBA1□HHS			SS8R (150W) Reversed			150	20	1000		50-1000			SS8R (100W) Reversed			
	IK2-SXBA1□MMS		10			500											
69	IK2-SXBA1□HHD		SS8R (150W) Reversed, double-slider	20		1000		50-800									
	IK2-SXBA1□MMD			10		500											
71	IK2-SXBA2□HHS		SS8C (150W) Straight	20		1000		50-1000									
	IK2-SXBA2□MMS			10		500											
73	IK2-SXBA2□HHD		SS8C (150W) Straight, double-slider	20		1000		50-800									
	IK2-SXBA2□MMD			10		500											
75	IK2-SXZB1□HHS			SS8R (100W) Reversed		100		20	1000		50-1000	SA7R Reversed					
	IK2-SXZB1□HMS				50-800												
77	IK2-SXZB1□HHD			SS8R (100W) Reversed, double-slider	50-800												
	IK2-SXZB1□HMD				50-800												
79	IK2-SYBB1□HHS				SS8R (100W) Reversed												50-1000
	IK2-SYBB1□HMS																50-1000
IK2-SYBB1□HLS	50-1000																

		Axis 1: Mount axis	Axis 2: Axis installed on axis 1	Axis 3: Axis installed on axis 2	Cable wiring 1: Wiring for axis 2	Cable wiring 2: Wiring for axis 3							
		Axis 2			Load capacity by axis 2 stroke								
Motor size	Lead (mm)	Maximum speed (mm/sec)	Stroke (mm)	50	100	150	200	250	300	350	400		
42□	12	600	50-200	3.0	3.0	2.5	2.5						
	6	300	50-200	6.0	6.0	5.0	5.0						
	12	600	250-400					2.5	2.0	2.0	2.0		
	6	300	250-400					5.0	4.0	4.0	4.0		
	12	600	50-200	3.0	3.0	2.5	2.5						
	6	300	50-200	6.0	6.0	5.0	5.0						
42□	12	600	250-400					2.5	2.0	2.0	2.0		
	6	300	250-400					5.0	4.0	4.0	4.0		
	12	600	50-200	4.5	4.5	4.0	3.0						
	6	300	50-200	9.0	9.0	8.0	6.0						
	12	600	250-400					3.0	3.0	3.0	3.0		
	6	300	250-400					6.0	6.0	6.0	6.0		
56□	16	450	50-300	8.0	8.0	7.0	7.0	6.0	6.0				
	8	220	50-300	16.0	16.0	15.0	12.5	9.0	8.0				
	16	450	350-400							6.0	5.5		
	8	220	200-400				15.0	12.5	12.5	12.0	10.5		
	16	450	50-300	8.0	8.0	7.0	7.0	6.0	6.0				
	8	220	50-300	16.0	16.0	15.0	12.5	9.0	8.0				
56□	16	450	350-400							6.0	5.5		
	8	220	200-400				15.0	12.5	12.5	12.0	10.5		
	16	360	50-250	2.0	2.0	2.0	2.0	1.5					
	8	180	50-250	4.0	4.0	3.5	3.5	2.5					
	4	90	50-250	8.0	7.0	5.0	4.0	3.0					
	16	400	300						1.5				
56□	8	200	300						3.0				
	4	100	150-300			7.0	7.0	5.5	5.5				
	16	360	50-300	2.0	2.0	2.0	2.0	1.5	1.5				
	8	180	50-300	4.0	4.0	3.5	3.5	3.0	3.0				
	4	90	50-300	8.0	8.0	7.0	7.0	6.0	5.5				

		Axis 2			Load capacity by axis 2 stroke								
Motor output (W)	Lead (mm)	Maximum speed (mm/sec)	Stroke (mm)	50	100	150	200	250	300	350	400		
20	12	800	50-200	3.0	3.0	2.5	2.5						
	6	400		6.0	6.0	5.0	5.0						
	12	800	250-400					2.5	2.0	2.0	2.0		
	6	400						5.0	4.0	4.0	4.0		
	12	800	50-200	3.0	3.0	2.5	2.5						
	6	400		6.0	6.0	5.0	5.0						
30	12	800	250-400					2.5	2.0	2.0	2.0		
	6	400						5.0	4.0	4.0	4.0		
	12	800	50-200	4.5	4.5	4.0	3.0						
	6	400		9.0	9.0	8.0	6.0						
	12	800	250-400					3.0	3.0	3.0	3.0		
	6	400						6.0	6.0	6.0	6.0		
60	16	800	50-300	8.0	8.0	7.0	7.0	6.0	6.0				
	8	400		16.0	16.0	15.0	12.5	9.0	8.0				
	16	800	350-400							6.0	5.5		
	8	400	200-400				15.0	12.5	12.5	12.0	10.5		
	16	800	50-300	8.0	8.0	7.0	7.0	6.0	6.0				
	8	400		16.0	16.0	15.0	12.5	9.0	8.0				
100	16	800	350-400							6.0	5.5		
	8	400	200-400				15.0	12.5	12.5	12.0	10.5		
	20	1000	50-350	12.0	12.0	11.5	11.0	10.0	8.5	7.0			
	10	500		24.0	20.5	15.5	12.5						
	20	1000	300-400						11.0	10.5	10.0		
	10	500	100-400		24.0	24.0	23.0	19.0	16.0	13.5	11.5		
60	20	1000	50-350	12.0	12.0	11.5	11.0	10.0	8.5	7.0			
	10	500		24.0	20.5	15.5	12.5						
	20	1000	300-400						11.0	10.5	10.0		
	10	500	100-400		24.0	24.0	23.0	19.0	16.0	13.5	11.5		
	16	800	50-250	2.0	2.0	2.0	2.0	1.5					
	8	400		4.0	4.0	3.5	3.5	2.5					
4	200	300	8.0	7.0	5.0	4.0	3.0						
16	800							1.5					
8	400	150-300						3.0					
4	200					7.0	7.0	5.5	5.5				
60	16	800	50-300	2.0	2.0	2.0	2.0	1.5	1.5				
	8	400		4.0	4.0	3.5	3.5	3.0	3.0				
	4	200	50-300	8.0	8.0	7.0	7.0	6.0	5.5				

## Tips on Selection

### 1. Differences between RCP2 and RCS2

#### Features of RCP2

- [1] Adopting a pulse motor.
- [2] Characterized by high thrust at low speed.
- [3] Less expensive than the RCS2.

#### Features of RCS2

- [1] Adopting a servo motor.
- [2] Able to operate at a constant thrust regardless of the speed.
- [3] Able to move at higher speeds than the RCP2.

### 2. Differences between X-axis Straight and Reversed Types

The X-axis reversed type can have a shorter dimension in the X-axis direction. When the 150-watt RCS2-SS8C (straight) and 150-watt SS8R (reversed) are compared, for example, the SS8R is shorter by 130 mm. Note, however, that the reversed type does not support configurations based on combination directions [3] and [4].

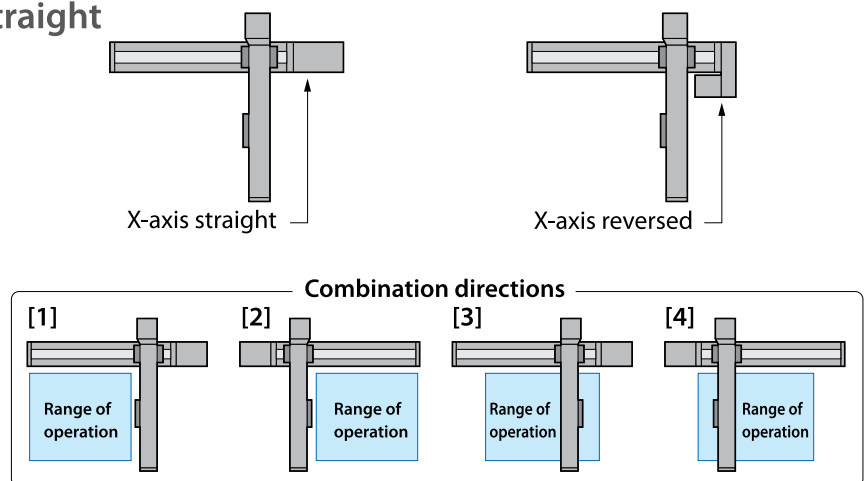

### 3. Differences between Single-slider and Double-slider Types

A double-slider consists of two sliders connected to each other and has a greater permissible load moment compared to a single-slider type. Accordingly, double-slider units are used as the X-axis in XY configurations with a long overhang. Note, however, that because the double-slider structure naturally has a longer slider section, a double-slider unit has a shorter stroke than a single-slider unit of the same total length.

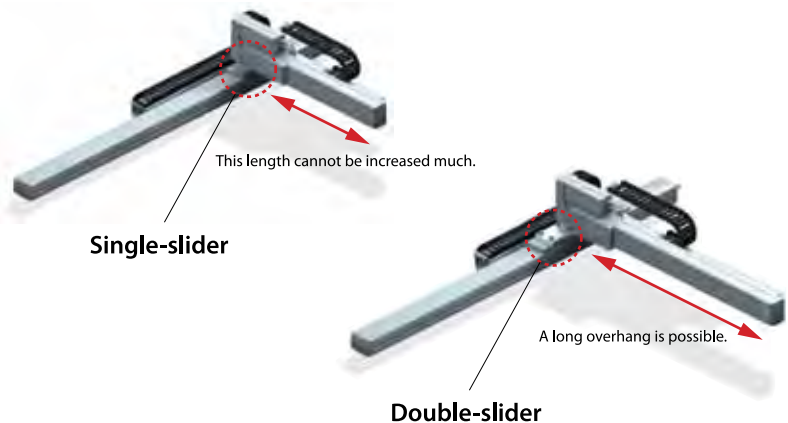



## Explanation of Items Comprising Model Name

### [IK Series, 2-axis combination unit]

IK2-□□□□□□-□-□□□□-□□-□□-□□-□□-□□-□□

[1] [2] [3] [4] [5] [6] [7] [8] [9] [10] [11] [14] [15] [16] [17] [18]

### [IK Series, 3-axis combination unit]

IK3-□□□□□□-□-□□□□-□□□□-□□□□-□□□□-□□□□-□□□□

[1] [2] [3] [4] [5] [6] [7] [8] [9] [10] [11] [12] [13] [14] [15] [16] [17] [18]

### [1]Axis configuration [2]Combined shape

Code	Model
P	RCP2
S	RCS2

Code	Combined shape	Name
XB	XYB	XY, base mount
XZ	XZ	Upright type
YB	YZB	Cross type, base mount
BB	XYB+ZB	XYB+Z, base mount

### [3]Configuration type

Code	Axis 1	Axis 2	Axis 3
A1	SS8R (150W)	SS8R (100W)	
A2	SS8C (150W)	SS8R (100W)	
B1	SS8R (100W)	SA7R	
B2	SS8C (100W)	SA7R	
C1	SS7R	SA6R	
C2	SS7C	SA6R	
D1	SS7R	SA5R	
D2	SS7C	SA5R	
G1	SS8R (100W)	SA7R	SA6R

### [4]Combination directions

XYB (XY, base mount) \*Only 1 and 2 are supported if the X-axis is of reversed type.

Code	1	2	3	4
Shape				

### XZ (Upright type)

Code	1	2	3	4
Shape				

### YZB (Cross type, base mount)

Code	1	2
Shape		

### [5]Speed type

Code	Type		
HH	High-speed	High-speed	
HM	High-speed	Medium-speed	
HL	High-speed	Low-speed	
MM	Medium-speed	Medium-speed	
HHH	High-speed	High-speed	High-speed
HMM	High-speed	High-speed	Medium-speed
HHL	High-speed	High-speed	Low-speed

### [6]X-Axis Slider Type

Code	Type
S	Single
D	Double

### [7]Encoder Type

Code	Type
I	Incremental
A	Absolute

The combination directions supported by the 3-axis configuration (XYB+Z-axes, base mount) are the same as those of the XYB configuration shown above.

### [8]Axis 1 stroke (cm)

5:50mm-100:1000mm  
(Can be set in 50-mm increments)

### [10]Axis 2 stroke (cm)

5:50mm-40:400mm  
(Can be set in 50-mm increments)

### [12]Axis 3 stroke (cm)

5:50mm-20:200mm  
(Can be set in 50-mm increments)

### [9]Axis 1 options

Code	Description
NM	Reversed-home specification
SR	Slider roller specification

### [11]Axis 2 options

Code	Description
B	Brake
NM	Reversed-home specification
SR	Slider roller specification

### [13]Axis 3 options

Code	Description
B	Brake
NM	Reversed-home specification
SR	Slider roller specification

Axis 1: Mount axis  
Axis 2: Axis installed on axis 1  
Axis 3: Axis 3: Axis installed on axis 2  
Cable wiring 1: Wiring for axis 2  
Cable wiring 2: Wiring for axis 3

### [14]Applicable controller

Code	Model
T1	XSEL-J/K
T2	SSEL, XSEL-P/Q
P1	PSEL, ROBONET

### [15]Cable length

Code	Description
1L	1m
3L	3m
5L	5m
<input type="checkbox"/> L	<input type="checkbox"/> m

### [16]Cable wiring 1

Code	Description
N	Cable only
CT	With cable track

### [17]Cable wiring 2

Code	Description
N	Cable only
CT	With cable track

### [18]Shipping configuration

Code	Description
K	Individual components (kit)

# Controller List

The IA kit supports the following controllers. For details on each controller, refer to the reference page describing the applicable controller.

	Exterior view	Features	Maximum number of positioning points	Input power supply	Reference page
<b>PCON</b>		A positioning controller for the RCP2 series. Pulse-train control and serial communication types are also available.	512	DC24V	Refer to the ROBO Cylinder General Catalog
<b>PSEL</b>		A program controller for the RCP2 series. Can be programmed using SEL language. 1-axis and 2-axis types are available.	1500	DC24V	P. 93
<b>SCON</b>		A positioning controller for the RCS2 series. Field networks are supported.	512	100 VAC Single-phase 200 VAC	Refer to the ROBO Cylinder General Catalog
<b>SSEL</b>		A program controller for the RCS2 series. Can be programmed using SEL language. 1-axis and 2-axis types are available.	1500	100 VAC Single-phase 200 VAC	P. 93
<b>XSEL-J/K</b>		For the RCS2 series. 3-axis and 4-axis configurations are supported. Two sets of 2-axis combination systems can be controlled. J type: Small size K type: Provides greater expandability because I/Os can be used.	3000	100 VAC Single-phase 200 VAC	P. 93
<b>XSEL-P/Q</b>		For the RCS2 series. 5-axis and 6-axis configurations are supported.	4000	Three-phase 200 VAC	P. 93

# IK2-PXBD1□□S

RCP2 2-axis Combinations X axis: SS7R (Reversed, Single-slider)  
Y axis: SA5R (Reversed)

**Model Details** Series — Type — Encoder type — Axis 1 (X axis) — Axis 2 (Y axis) — Controllers — Cable — Shipping configuration

IK2 — PXBD1□□S —  —  —  —  —  —  —  —  —

**Combination directions** 1-2

**Differences between Single-slider and Double-slider Types**  
HH: X high-speed, Y high-speed  
HM: X high-speed, Y medium-speed

**Encoder type**  
I: Incremental

**Stroke (mm)**  
5: 50mm  
(Can be set in 50-mm increments)

**Options**  
NM: Opposite-home specification  
SR: Slider roller specification

**Controllers** P1

**Cable**  
**Cable length**  
1L: 1m  
3L: 3m  
5L: 5m  
L: □m  
**Wiring 1**  
N: Cable only  
**Wiring 2**  
CT: With cable track

**Shipping configuration**  
K: Individual components (kit)

\* Refer to P.10 for details on the items comprising the model name.

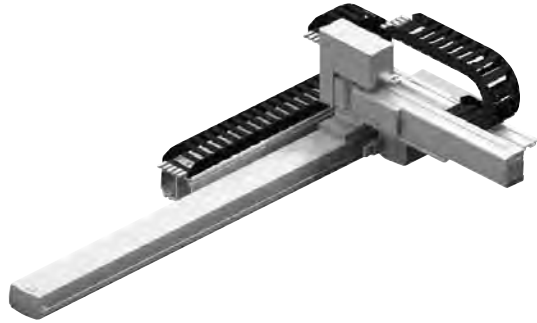

Both wiring 1 and wiring 2 assume use of a cable track.

**Maximum Stroke**

X axis 600 mm

Y axis 200 mm

**Maximum Speed (High-speed type)**

X axis 400 mm/s

Y axis 600 mm/s

**Maximum Load Capacity**

Y-axis stroke	X high-speed, Y high-speed	X high-speed, Y medium-speed
50mm	3.0kg	6.0kg
100mm	3.0kg	6.0kg
150mm	2.5kg	5.0kg
200mm	2.5kg	5.0kg

**List of Options**

Name	Option code
Opposite-home specification	NM
Slider roller specification	SR

**Specifications**

Item	X axis	Y axis
Axis model	RCP2-SS7R	RCP2-SA5R
Stroke (Can be set in 50-mm increments)	50-600mm	50-200mm
Max speed	HH type: 400mm/s HM type: 350mm/s	High-speed type: 600mm/s Medium-speed type: 300mm/s
Motor size	42-square pulse motor	
Ball screw lead	High-speed type: 12mm	High-speed type: 12mm Medium-speed type: 6mm
Drive method	Ball screw, ø10 mm, rolled, C10	
Positioning repeatability	±0.02mm	
Base material	Dedicated alloy steel	Aluminum
Surrounding air temperature/humidity	0 to 40°C, 85% RH or below (non-condensing)	



Dimensions

You can download CAD drawings from our website.

www.intelligentactuator.com

2D CAD

Note 1. The connected position shown in the drawing defines the home.  
 Note 2. Both wiring 1 and wiring 2 assume use of a cable track.  
 Note 3. For details on the cable track, refer to P.90.  
 Note 4. For details on the bracket on the moving end of the cable track, refer to P.90.

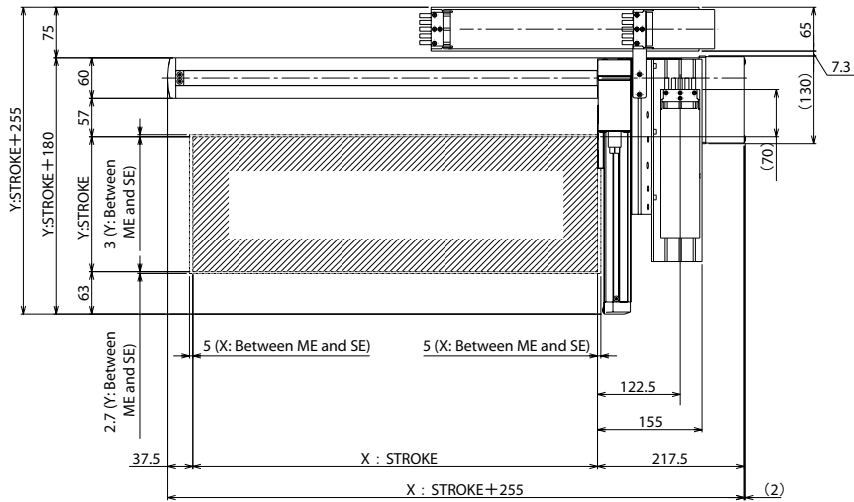
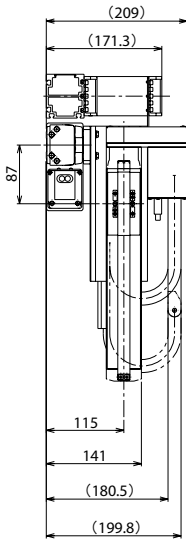

ME: Mechanical end  
 SE: Stroke end

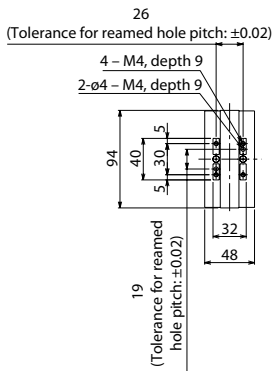

Detail view of Y-axis slider

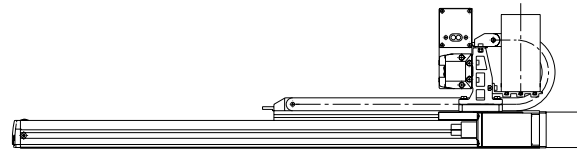

Detail view of slot in bottom face of X-axis base

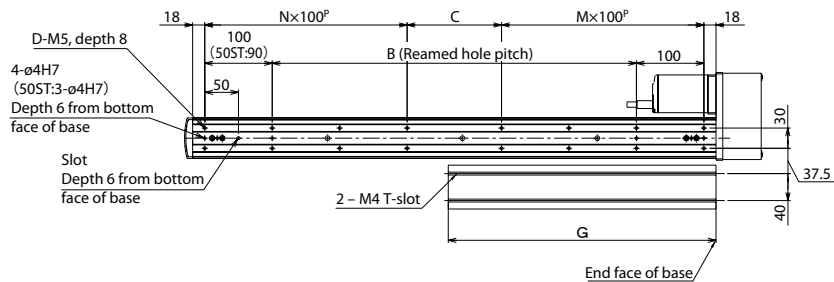

■ Dimensions by Stroke

Detail view of X-axis installation

X: Model	50	100	150	200	250	300	350	400	450	500	550	600
B	0	40	90	140	190	240	290	340	390	440	490	540
C	90	40	90	140	190	40	90	140	190	40	90	140
D	6	8	8	8	8	12	12	12	12	16	16	16
M	1	1	1	1	1	2	2	2	2	3	3	3
N	0	1	1	1	1	2	2	2	2	3	3	3
G	122	147	172	197	222	247	272	297	322	347	372	397

Controllers

Applicable controller



Refer to P. 91 for the controllers.

# IK2-PXBD1□□D

RCP2 2-axis Combinations X axis: SS7R (Reversed, Double-slider)  
Y axis: SA5R (Reversed)

**Model Details** Series **IK2** Type **PXBD1□□D** Encoder type **I** Axis 1 (X axis) **□** Axis 2 (Y axis) **□** Controllers **P1** Cable **□** Shipping configuration **□**

**Combination directions** 1-2

**Differences between Single-slider and Double-slider Types**  
HH: X high-speed, Y high-speed  
HM: X high-speed, Y medium-speed

**Encoder type**  
I: Incremental

**Stroke (mm)**  
5: 50mm  
? (Can be set in 50-mm increments)

**Options**  
NM: Opposite-home specification  
SR: Slider roller specification

**Cable length**  
1L: 1m  
3L: 3m  
5L: 5m  
□L: □m

**Wiring 1**  
N: Cable only

**Wiring 2**  
CT: With cable track

**Shipping configuration**  
K: Individual components (kit)

\* Refer to P.10 for details on the items comprising the model name.

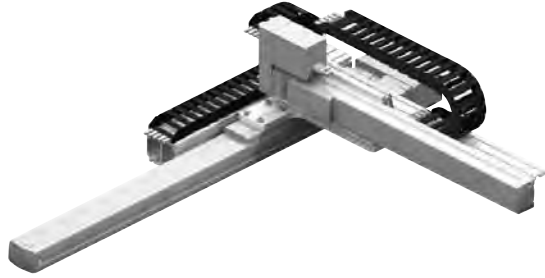

**Maximum Stroke**

X axis 450 mm

Y axis 400 mm

**Maximum Speed (High-speed type)**

X axis 400 mm/s

Y axis 600 mm/s

**Maximum Load Capacity**

Y-axis stroke	X high-speed, Y high-speed	X high-speed, Y medium-speed
250mm	2.5kg	5.0kg
300mm	2.0kg	4.0kg
350mm	2.0kg	4.0kg
400mm	2.0kg	4.0kg

Both wiring 1 and wiring 2 assume use of a cable track.

**List by Stroke**

		Incremental			
Y-axis stroke		250	300	350	400
X-axis stroke	50	-	-	-	-
	100	-	-	-	-
	150	-	-	-	-
	200	-	-	-	-
	250	-	-	-	-
	300	-	-	-	-
	350	-	-	-	-
	400	-	-	-	-
	450	-	-	-	-

**Cable track**

Wiring 1 (Next to X-axis)	X-axis stroke	50-300	350-450
		-	-
Wiring 2 (Next to Y-axis)	Y-axis stroke	250-400	-
		-	-

**List by Cable Length**

Type	Cable code	Length
Standard type	1L	1m
	3L	3m
	5L	5m

\* Axis 1 comes with a standard cable, while axis 2 comes with a robot cable.

\* Refer to P. 90 for lengths other than those specified above.

**List of Options**

Name	Option code	-
Opposite-home specification	NM	-
Slider roller specification	SR	Axis 1 (X-axis) Axis 2 (Y-axis)

**Specifications**

Item	X axis	Y axis
Axis model	RCP2-SS7R	RCP2-SA5R
Stroke (Can be set in 50-mm increments)	50-450mm	250-400mm
Max speed	HH type: 400mm/s HM type: 350mm/s	High-speed type: 600mm/s Medium-speed type: 300mm/s
Motor size	42-square pulse motor	
Ball screw lead	High-speed type: 12mm	High-speed type: 12mm Medium-speed type: 6mm
Drive method	Ball screw, ø10 mm, rolled, C10	
Positioning repeatability	±0.02mm	
Base material	Dedicated alloy steel	Aluminum
Surrounding air temperature/humidity	0 to 40°C, 85% RH or below (non-condensing)	

Dimensions

You can download CAD drawings from our website. [www.intelligentactuator.com](http://www.intelligentactuator.com)

2D CAD

Note 1. The connected position shown in the drawing defines the home.  
 Note 2. Both wiring 1 and wiring 2 assume use of a cable track.  
 Note 3. For details on the cable track, refer to P. 90.  
 Note 4. For details on the bracket on the moving end of the cable track, refer to P. 90.

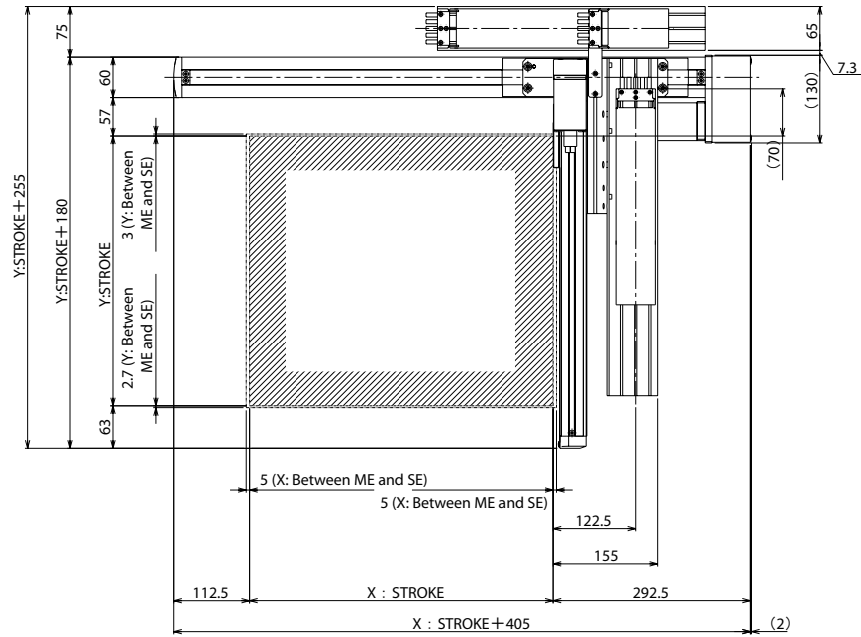
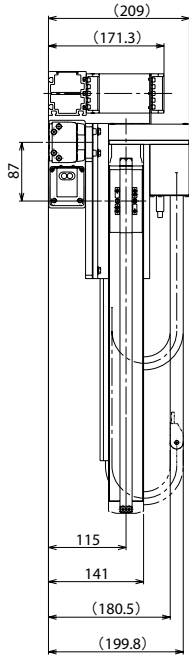

ME: Mechanical end  
 SE: Stroke end

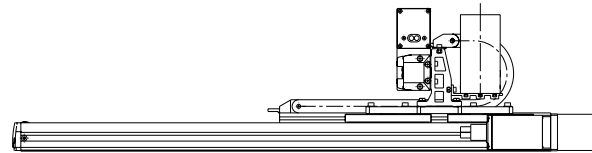

26  
 (Tolerance for reamed hole pitch: ±0.02)

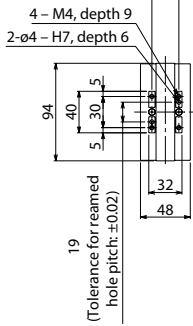

Detail view of Y-axis slider



Detail view of slot in bottom face of X-axis base

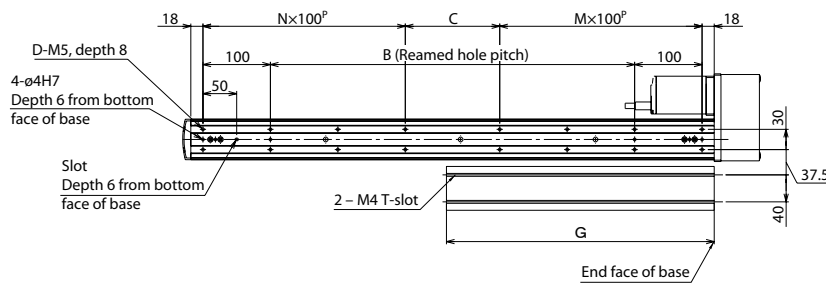

Detail view of X-axis installation

■ Dimensions by Stroke

X: Nominal stroke	200	250	300	350	400	450	500	550	600
X: Effective stroke	50	100	150	200	250	300	350	400	450
B	140	190	240	290	340	390	440	490	540
C	140	190	40	90	140	190	40	90	140
D	8	8	12	12	12	12	16	16	16
M	1	1	2	2	2	2	3	3	3
N	1	1	2	2	2	2	3	3	3
G	197	222	247	272	297	322	347	372	397

Controllers

Applicable controller

Refer to P. 91 for the controllers.



# IK2-PXBD2□□S

RCP2 2-axis Combinations X axis: SS7C (Straight, Single-slider)  
Y axis: SA5R (Reversed)

**Model Details** Series **IK2** Type **PXBD2□□S** Encoder type **I** Axis 1 (X axis) **□** Axis 2 (Y axis) **□** Controllers **P1** Cable **□** Shipping configuration **□**

**Combination directions** 1-4

**Differences between Single-slider and Double-slider Types**  
HH: X high-speed, Y high-speed  
HM: X high-speed, Y medium-speed

**Encoder type** I: Incremental

**Stroke (mm)**  
5: 50mm  
? (Can be set in 50-mm increments)

**Options**  
NM: Opposite-home specification  
SR: Slider roller specification

**Cable length**  
1L: 1m  
3L: 3m  
5L: 5m  
□L: □m

**Wiring 1** N: Cable only  
**Wiring 2** CT: With cable track

**Shipping configuration** K: Individual components (kit)

\* Refer to P.10 for details on the items comprising the model name.

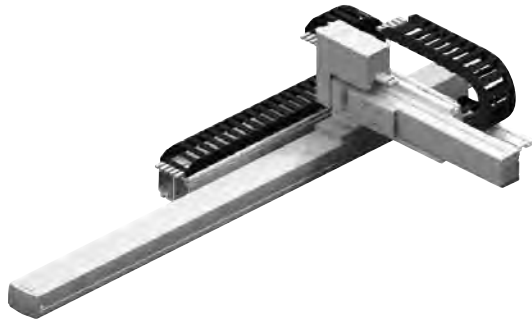

### Maximum Stroke

**X axis** 600 mm

**Y axis** 200 mm

### Maximum Speed (High-speed type)

**X axis** 400 mm/s

**Y axis** 600 mm/s

### Maximum Load Capacity

Y-axis stroke	X high-speed, Y high-speed	X high-speed, Y medium-speed
50mm	3.0kg	6.0kg
100mm	3.0kg	6.0kg
150mm	2.5kg	5.0kg
200mm	2.5kg	5.0kg

Both wiring 1 and wiring 2 assume use of a cable track.

### List by Stroke

		Incremental			
Y-axis stroke		50	100	150	200
X-axis stroke	50	-	-	-	-
	100	-	-	-	-
	150	-	-	-	-
	200	-	-	-	-
	250	-	-	-	-
	300	-	-	-	-
	350	-	-	-	-
	400	-	-	-	-
	450	-	-	-	-
	500	-	-	-	-
	550	-	-	-	-
600	-	-	-	-	

### Cable track

	X-axis stroke	50-300	350-600
Wiring 1 (Next to X-axis)	Y-axis stroke	-	-
Wiring 2 (Next to Y-axis)	Y-axis stroke	50-200	-
		-	-

### List of Options

Name	Option code	
Opposite-home specification	<b>NM</b>	
Slider roller specification	<b>SR</b>	Axis 1 (X-axis) Axis 2 (Y-axis)

### List by Cable Length

Type	Cable code	Length
Standard type	<b>1L</b>	1m
	<b>3L</b>	3m
	<b>5L</b>	5m

\* Axis 1 comes with a standard cable, while axis 2 comes with a robot cable.

\* Refer to P. 90 for lengths other than those specified above.

### Specifications

Item	X axis	Y axis
Axis model	RCP2-SS7C	RCP2-SA5R
Stroke (Can be set in 50-mm increments)	50-600mm	50-200mm
Max speed	HH type: 400mm/s HM type: 350mm/s	High-speed type: 600mm/s Medium-speed type: 300mm/s
Motor size	42-square pulse motor	
Ball screw lead	High-speed type: 12mm	High-speed type: 12mm Medium-speed type: 6mm
Drive method	Ball screw, ø10 mm, rolled, C10	
Positioning repeatability	±0.02mm	
Base material	Dedicated alloy steel	Aluminum
Surrounding air temperature/humidity	0 to 40°C, 85% RH or below (non-condensing)	

Dimensions

You can download CAD drawings from our website.

www.intelligentactuator.com

2D CAD

Note 1. The connected position shown in the drawing defines the home.  
 Note 2. Both wiring 1 and wiring 2 assume use of a cable track.  
 Note 3. For details on the cable track, refer to P. 90.  
 Note 4. For details on the bracket on the moving end of the cable track, refer to P. 90.

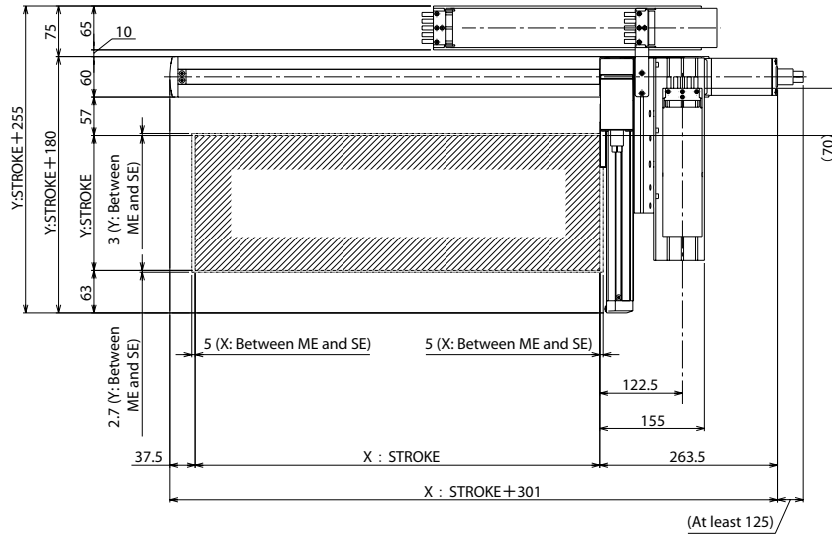
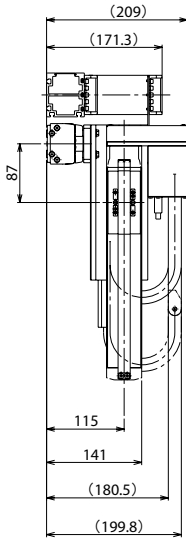

ME: Mechanical end  
 SE: Stroke end

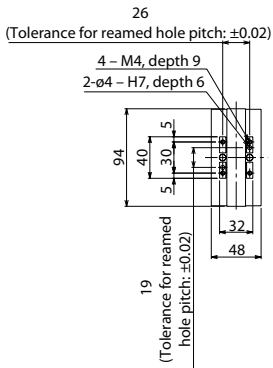
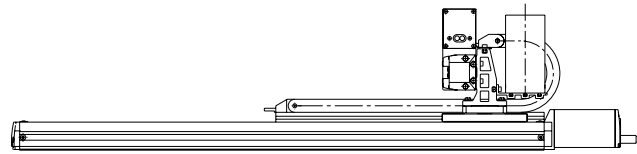

Detail view of Y-axis slider



Detail view of slot in bottom face of X-axis base

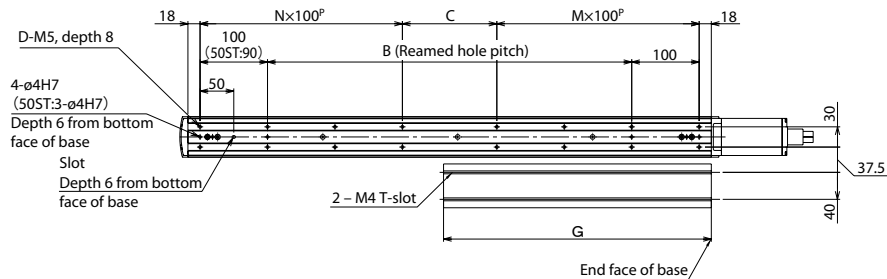

Detail view of X-axis installation

■ Dimensions by Stroke

X: Model	50	100	150	200	250	300	350	400	450	500	550	600
B	0	40	90	140	190	240	290	340	390	440	490	540
C	90	40	90	140	190	40	90	140	190	40	90	140
D	6	8	8	8	8	12	12	12	12	16	16	16
M	1	1	1	1	1	2	2	2	2	3	3	3
N	0	1	1	1	1	2	2	2	2	3	3	3
G	122	147	172	197	222	247	272	297	322	347	372	397

Controllers

Applicable controller



Refer to P. 91 for the controllers.

# IK2-PXBD2□□D

RCP2 2-axis Combinations X axis: SS7C (Straight, Double-slider)  
Y axis: SA5R (Reversed)

**Model Details** Series **IK2** Type **PXBD2□□D** Encoder type **I** Axis 1 (X axis) **□** Axis 2 (Y axis) **□** Controllers **P1** Cable **□** Shipping configuration **□**

**Combination directions** 1-4

**Differences between Single-slider and Double-slider Types**  
HH: X high-speed, Y high-speed  
HM: X high-speed, Y medium-speed

**Encoder type**  
I: Incremental

**Stroke (mm)**  
5: 50mm  
? (Can be set in 50-mm increments)

**Options**  
NM: Opposite-home specification  
SR: Slider roller specification

**Cable length**  
1L: 1m  
3L: 3m  
5L: 5m  
□L: □m

**Wiring 1**  
N: Cable only  
CT: With cable track

**Wiring 2**  
□

**Shipping configuration**  
K: Individual components (kit)

\* Refer to P.10 for details on the items comprising the model name.

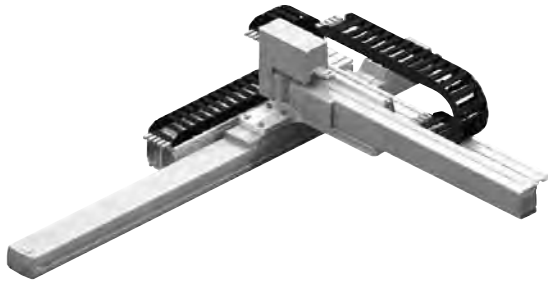

**Maximum Stroke**

X axis 450 mm

Y axis 400 mm

**Maximum Speed (High-speed type)**

X axis 400 mm/s

Y axis 600 mm/s

**Maximum Load Capacity**

Y-axis stroke	X high-speed, Y high-speed	X high-speed, Y medium-speed
250mm	2.5kg	5.0kg
300mm	2.0kg	4.0kg
350mm	2.0kg	4.0kg
400mm	2.0kg	4.0kg

Both wiring 1 and wiring 2 assume use of a cable track.

**List by Stroke**

		Incremental			
Y-axis stroke		250	300	350	400
X-axis stroke	50	-	-	-	-
	100	-	-	-	-
	150	-	-	-	-
	200	-	-	-	-
	250	-	-	-	-
	300	-	-	-	-
	350	-	-	-	-
	400	-	-	-	-
	450	-	-	-	-

**List by Cable Length**

Type	Cable code	Length
Standard type	1L	1m
	3L	3m
	5L	5m

\* Axis 1 comes with a standard cable, while axis 2 comes with a robot cable.

\* Refer to P. 90 for lengths other than those specified above.

**Cable track**

Wiring 1 (Next to X-axis)	X-axis stroke	50-300	350-450
		-	-
Wiring 2 (Next to Y-axis)	Y-axis stroke	250-400	-
		-	-

**List of Options**

Name	Option code	
Opposite-home specification	NM	
Slider roller specification	SR	Axis 1 (X-axis) Axis 2 (Y-axis)

**Specifications**

Item	X axis	Y axis
Axis model	RCP2-SS7C	RCP2-SA5R
Stroke (Can be set in 50-mm increments)	50-450mm	250-400mm
Max speed	HH type: 400mm/s HM type: 350mm/s	High-speed type: 600mm/s Medium-speed type: 300mm/s
Motor size	42-square pulse motor	
Ball screw lead	High-speed type: 12mm	High-speed type: 12mm Medium-speed type: 6mm
Drive method	Ball screw, ø10 mm, rolled, C10	
Positioning repeatability	±0.02mm	
Base material	Dedicated alloy steel	Aluminum
Surrounding air temperature/humidity	0 to 40°C, 85% RH or below (non-condensing)	

Dimensions

You can download CAD drawings from our website.

www.intelligentactuator.com

2D CAD

Note 1. The connected position shown in the drawing defines the home.  
 Note 2. Both wiring 1 and wiring 2 assume use of a cable track.  
 Note 3. For details on the cable track, refer to P. 90.  
 Note 4. For details on the bracket on the moving end of the cable track, refer to P. 90.

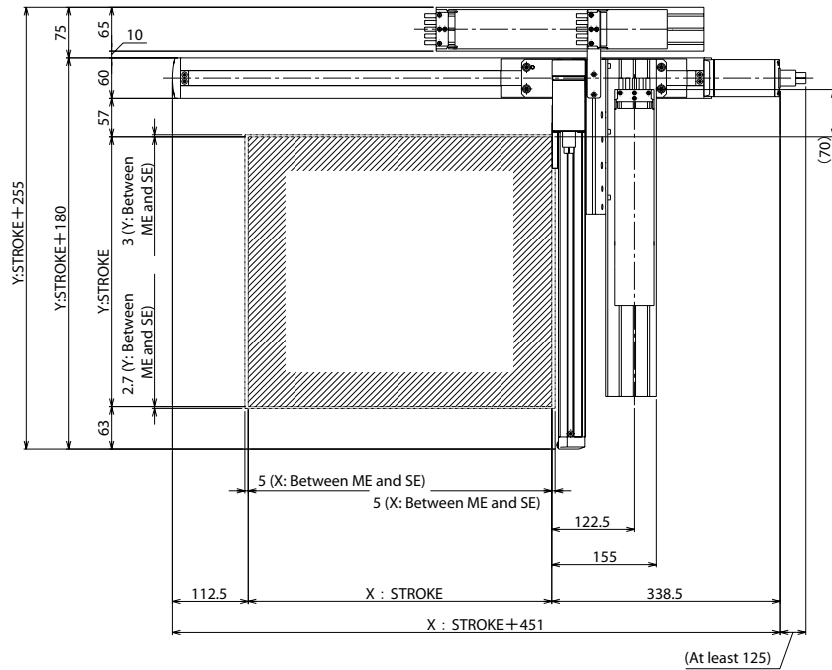
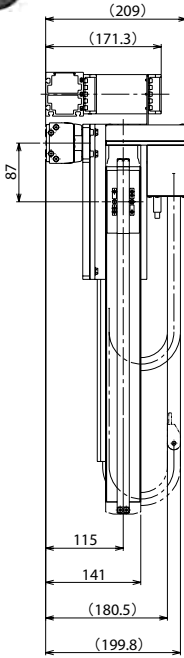

ME: Mechanical end  
 SE: Stroke end

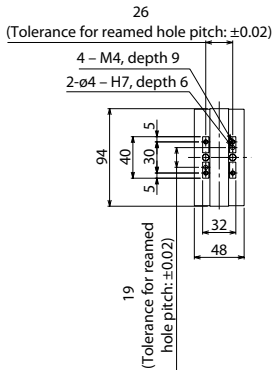
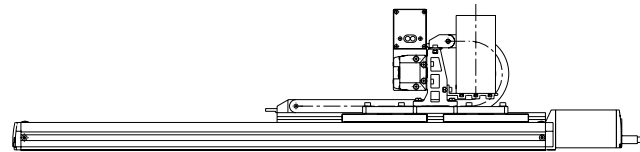

Detail view of Y-axis slider



Detail view of slot in bottom face of X-axis base

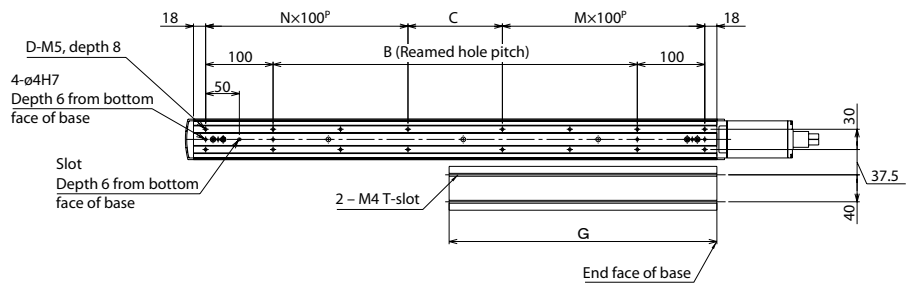

Detail view of X-axis installation

Dimensions by Stroke

X: Nominal stroke	200	250	300	350	400	450	500	550	600
X: Effective stroke	50	100	150	200	250	300	350	400	450
B	140	190	240	290	340	390	440	490	540
C	140	190	40	90	140	190	40	90	140
D	8	8	12	12	12	12	16	16	16
M	1	1	2	2	2	2	3	3	3
N	1	1	2	2	2	2	3	3	3
G	197	222	247	272	297	322	347	372	397

Controllers

Applicable controller



Refer to P. 91 for the controllers.

# IK2-PXBC1□□S

RCP2 2-axis Combinations X axis: SS7R (Reversed, Single-slider)  
Y axis: SASR (Reversed)

**Model Details** Series **IK2** Type **PXBC1□□S** Encoder type **I** Axis 1 (X axis) **□** Axis 2 (Y axis) **□** Controllers **P1** Cable **□** Shipping configuration **□**

**Combination directions** 1-2  
**Differences between Single-slider and Double-slider Types**  
HH: X high-speed, Y high-speed  
HM: X high-speed, Y medium-speed

**Encoder type** I: Incremental

**Stroke (mm)**  
5: 50mm  
? (Can be set in 50-mm increments)

**Options**  
NM: Opposite-home specification  
SR: Slider roller specification

**Cable length**  
1L: 1m  
3L: 3m  
5L: 5m  
□L: □m

**Wiring 1** N: Cable only  
**Wiring 2** CT: With cable track

**Shipping configuration** K: Individual components (kit)

\* Refer to P.10 for details on the items comprising the model name.

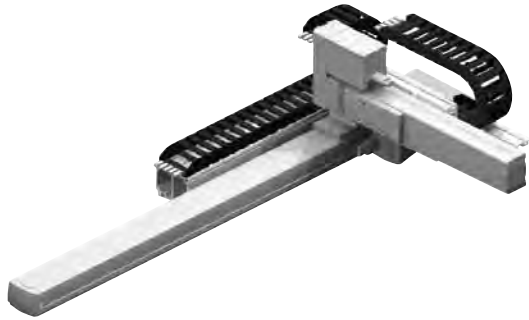

### Maximum Stroke

X axis 600 mm

Y axis 200 mm

### Maximum Speed (High-speed type)

X axis 400 mm/s

Y axis 600 mm/s

### Maximum Load Capacity

Y-axis stroke	X high-speed, Y high-speed	X high-speed, Y medium-speed
50mm	4.5kg	9.0kg
100mm	4.5kg	9.0kg
150mm	4.0kg	8.0kg
200mm	3.0kg	6.0kg

Both wiring 1 and wiring 2 assume use of a cable track.

### List by Stroke

		Incremental			
Y-axis stroke		50	100	150	200
X-axis stroke	50	-	-	-	-
	100	-	-	-	-
	150	-	-	-	-
	200	-	-	-	-
	250	-	-	-	-
	300	-	-	-	-
	350	-	-	-	-
	400	-	-	-	-
	450	-	-	-	-
	500	-	-	-	-
550	-	-	-	-	
600	-	-	-	-	

### Cable track

Wiring	Stroke	50-300	350-600
Wiring 1 (Next to X-axis)	X-axis stroke	50-300	350-600
Wiring 2 (Next to Y-axis)	Y-axis stroke	50-200	-

### List of by Cable Length

Type	Cable code	Length
Standard type	1L	1m
	3L	3m
	5L	5m

\* Axis 1 comes with a standard cable, while axis 2 comes with a robot cable.

\* Refer to P.90 for lengths other than those specified above.

### List of Options

Name	Option code	
Opposite-home specification	NM	
Slider roller specification	SR	Axis 1 (X-axis) Axis 2 (Y-axis)

### Specifications

Item	X axis	Y axis
Axis model	RCP2-SS7R	RCP2-SA6R
Stroke (Can be set in 50-mm increments)	50-600mm	50-200mm
Max speed	HH type: 400mm/s HM type: 250mm/s	High-speed type: 600mm/s Medium-speed type: 300mm/s
Motor size	42-square pulse motor	
Ball screw lead	High-speed type: 12mm	High-speed type: 12mm Medium-speed type: 6mm
Drive method	Ball screw, ø10 mm, rolled, C10	
Positioning repeatability	±0.02mm	
Base material	Dedicated alloy steel	Aluminum
Surrounding air temperature/humidity	0 to 40°C, 85% RH or below (non-condensing)	



Dimensions

You can download CAD drawings from our website.

www.intelligentactuator.com

2D CAD

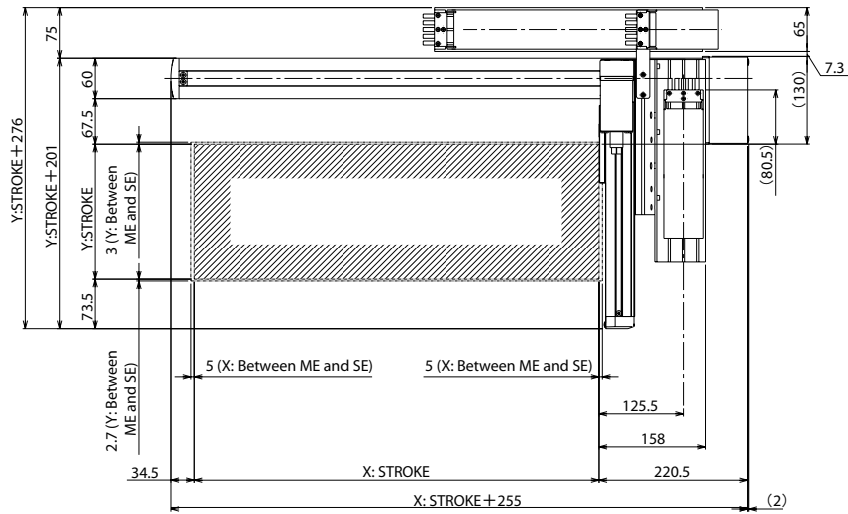
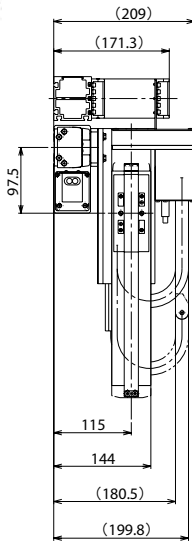

ME: Mechanical end  
SE: Stroke end

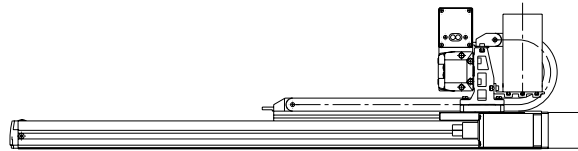

31  
(Tolerance for reamed hole pitch: ±0.02)

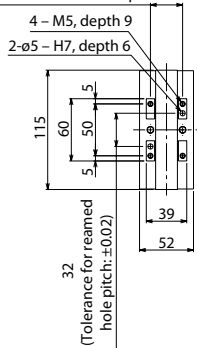

Detail view of Y-axis slider

Detail view of slot in bottom face of X-axis base

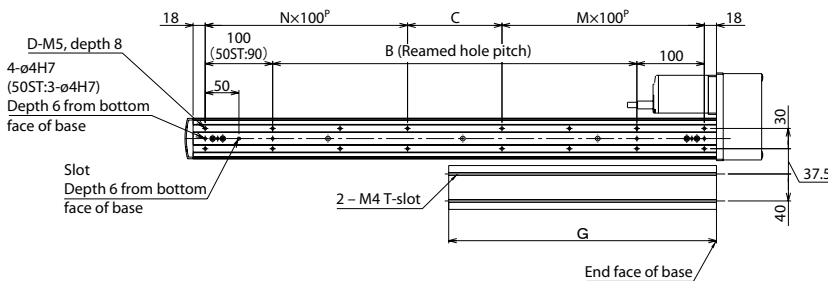

Detail view of X-axis installation

Dimensions by Stroke

X: Model	50	100	150	200	250	300	350	400	450	500	550	600
B	0	40	90	140	190	240	290	340	390	440	490	540
C	90	40	90	140	190	40	90	140	190	40	90	140
D	6	8	8	8	8	12	12	12	12	16	16	16
M	1	1	1	1	1	2	2	2	2	3	3	3
N	0	1	1	1	1	2	2	2	2	3	3	3
G	122	147	172	197	222	247	272	297	322	347	372	397

Controllers

Applicable controller



Refer to P. 91 for the controllers.

# IK2-PXBC1□□D

RCP2 2-axis Combinations X axis: SS7R (Reversed, Double-slider)  
Y axis: SA5R (Reversed)

**Model Details** Series **IK2** Type **PXBC1□□D** Encoder type **I** Axis 1 (X axis) **□** Axis 2 (Y axis) **□** Controllers **P1** Cable **□** Shipping configuration **□**

**Combination directions** 1-2

**Differences between Single-slider and Double-slider Types**  
HH: X high-speed, Y high-speed  
HM: X high-speed, Y medium-speed

**Encoder type**  
I: Incremental

**Stroke (mm)**  
5: 50mm  
? (Can be set in 50-mm increments)

**Options**  
NM: Opposite-home specification  
SR: Slider roller specification

**Cable length**  
1L: 1m  
3L: 3m  
5L: 5m  
□L: □m

**Wiring 1**  
N: Cable only

**Wiring 2**  
CT: With cable track

**Shipping configuration**  
K: Individual components (kit)

\* Refer to P.10 for details on the items comprising the model name.

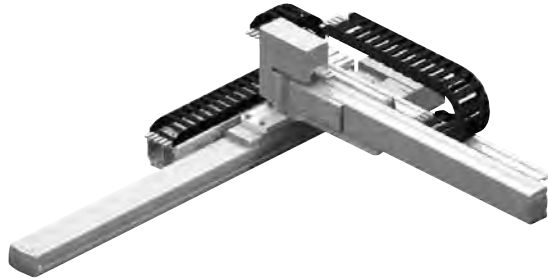

**Maximum Stroke**

X axis 450 mm

Y axis 400 mm

**Maximum Speed (High-speed type)**

X axis 400 mm/s

Y axis 600 mm/s

**Maximum Load Capacity**

Y-axis stroke	X high-speed, Y high-speed	X high-speed, Y medium-speed
250mm	3.0kg	6.0kg
300mm	3.0kg	6.0kg
350mm	3.0kg	6.0kg
400mm	3.0kg	6.0kg

Both wiring 1 and wiring 2 assume use of a cable track.

**List by Stroke**

		Incremental			
Y-axis stroke		250	300	350	400
X-axis stroke	50	-	-	-	-
	100	-	-	-	-
	150	-	-	-	-
	200	-	-	-	-
	250	-	-	-	-
	300	-	-	-	-
	350	-	-	-	-
	400	-	-	-	-
	450	-	-	-	-

**Cable track**

Wiring 1 (Next to X-axis)	X-axis stroke	50-300	350-450
			-
Wiring 2 (Next to Y-axis)	Y-axis stroke	250-400	-
			-

**List by Cable Length**

Type	Cable code	Length
Standard type	1L	1m
	3L	3m
	5L	5m

\* Axis 1 comes with a standard cable, while axis 2 comes with a robot cable.

\* Refer to P. 90 for lengths other than those specified above.

**List of Options**

Name	Option code	
Opposite-home specification	NM	
Slider roller specification	SR	Axis 1 (X-axis) Axis 2 (Y-axis)

**Specifications**

Item	X axis	Y axis
Axis model	RCP2-SS7R	RCP2-SA6R
Stroke (Can be set in 50-mm increments)	50-450mm	250-400mm
Max speed	HH type: 400mm/s HM type: 250mm/s	High-speed type: 600mm/s Medium-speed type: 300mm/s
Motor size	42-square pulse motor	
Ball screw lead	High-speed type: 12mm	High-speed type: 12mm Medium-speed type: 6mm
Drive method	Ball screw, ø10 mm, rolled, C10	
Positioning repeatability	±0.02mm	
Base material	Dedicated alloy steel	Aluminum
Surrounding air temperature/humidity	0 to 40°C, 85% RH or below (non-condensing)	

Dimensions

You can download CAD drawings from our website.

www.intelligentactuator.com

2D CAD

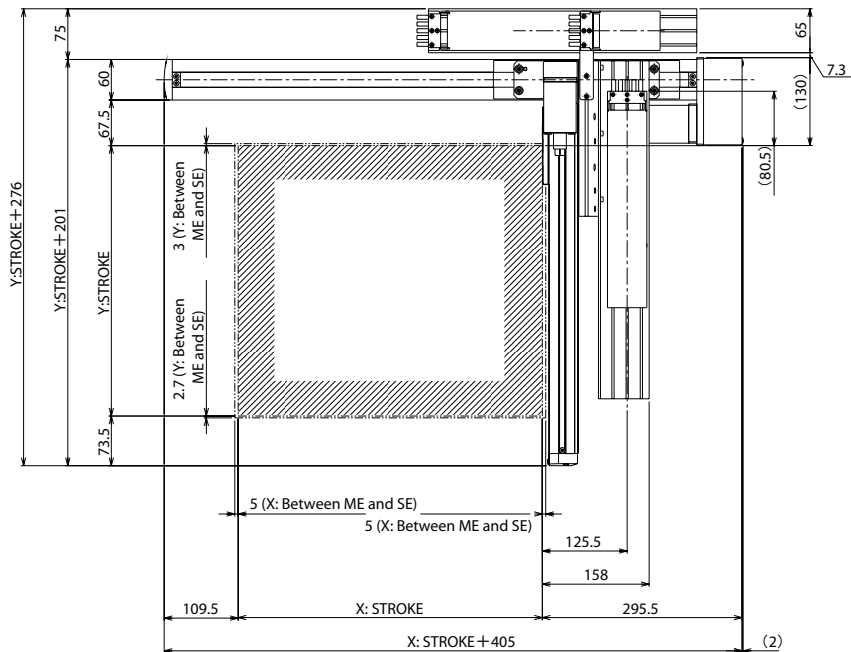
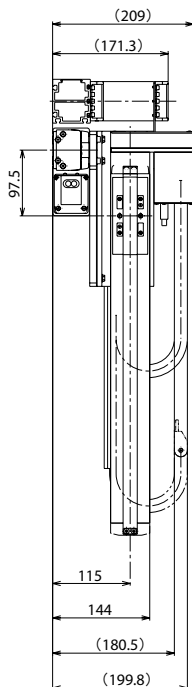

Note 1. The connected position shown in the drawing defines the home.

Note 2. Both wiring 1 and wiring 2 assume use of a cable track.

Note 3. For details on the cable track, refer to P. 90.

Note 4. For details on the bracket on the moving end of the cable track, refer to P. 90.

31  
(Tolerance for reamed hole pitch: ±0.02)

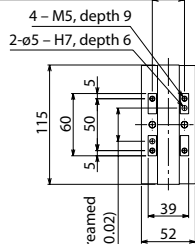

Detail view of Y-axis slider



Detail view of slot in bottom face of X-axis base

ME: Mechanical end  
SE: Stroke end

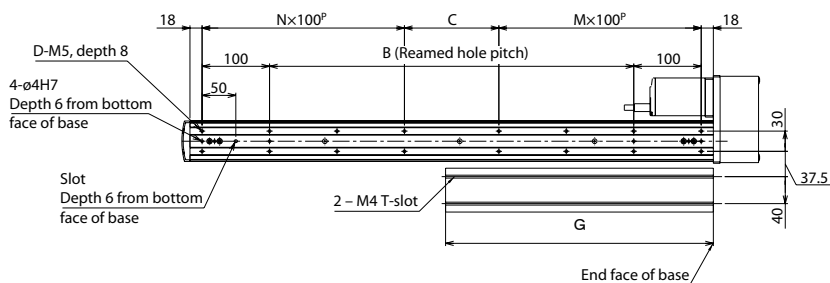
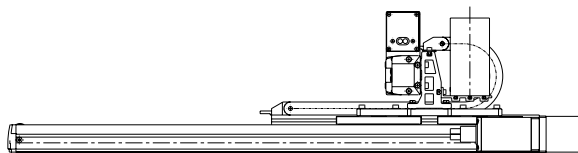

Detail view of X-axis installation

■ Dimensions by Stroke

X: Nominal stroke	200	250	300	350	400	450	500	550	600
X: Effective stroke	50	100	150	200	250	300	350	400	450
B	140	190	240	290	340	390	440	490	540
C	140	190	40	90	140	190	40	90	140
D	8	8	12	12	12	12	16	16	16
M	1	1	2	2	2	2	3	3	3
N	1	1	2	2	2	2	3	3	3
G	197	222	247	272	297	322	347	372	397

Controllers

Applicable controller



Refer to P. 91 for the controllers.

# IK2-PXBC2□□S

RCP2 2-axis Combinations X axis: SS7C (Straight, Single-slider)  
Y axis: SA6R (Reversed)

**Model Details** Series  Type  Encoder type  Axis 1 (X axis)  Axis 2 (Y axis)  Controllers  Cable  Shipping configuration

**IK2** **PXBC2**   **S**   **P1**

**Combination directions** 1-4

**Differences between Single-slider and Double-slider Types**  
HH: X high-speed, Y high-speed  
HM: X high-speed, Y medium-speed

**Encoder type** I: Incremental

**Stroke (mm)**  
5: 50mm  
? (Can be set in 50-mm increments)

**Options**  
NM: Opposite-home specification  
SR: Slider roller specification

**Cable length**  
1L: 1m  
3L: 3m  
5L: 5m  
 L:  m

**Wiring 1** N: Cable only  
**Wiring 2** CT: With cable track

**Shipping configuration** K: Individual components (kit)

\* Refer to P.10 for details on the items comprising the model name.

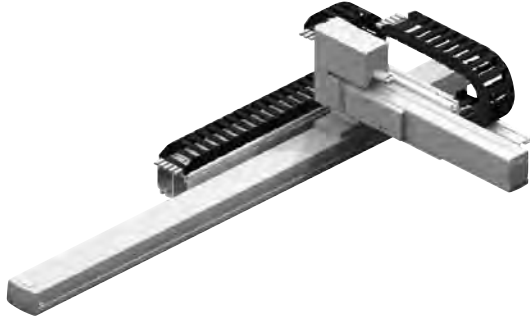

### Maximum Stroke

X axis 600 mm

Y axis 200 mm

### Maximum Speed (High-speed type)

X axis 400 mm/s

Y axis 600 mm/s

### Maximum Load Capacity

Y-axis stroke	X high-speed, Y high-speed	X high-speed, Y medium-speed
50mm	4.5kg	9.0kg
100mm	4.5kg	9.0kg
150mm	4.0kg	8.0kg
200mm	3.0kg	6.0kg

Both wiring 1 and wiring 2 assume use of a cable track.

### List by Stroke

		Incremental			
Y-axis stroke		50	100	150	200
X-axis stroke	50	-	-	-	-
	100	-	-	-	-
	150	-	-	-	-
	200	-	-	-	-
	250	-	-	-	-
	300	-	-	-	-
	350	-	-	-	-
	400	-	-	-	-
	450	-	-	-	-
	500	-	-	-	-
550	-	-	-	-	
600	-	-	-	-	

### Cable track

Wiring 1 (Next to X-axis)	X-axis stroke	50-300	350-600
			-
Wiring 2 (Next to Y-axis)	Y-axis stroke	50-200	-
			-

### List by Cable Length

Type	Cable code	Length
Standard type	1L	1m
	3L	3m
	5L	5m

\* Axis 1 comes with a standard cable, while axis 2 comes with a robot cable.

\* Refer to P.90 for lengths other than those specified above.

### List of Options

Name	Option code	
Opposite-home specification	NM	
Slider roller specification	SR	Axis 1 (X-axis) Axis 2 (Y-axis)

### Specifications

Item	X axis	Y axis
Axis model	RCP2-SS7C	RCP2-SA6R
Stroke (Can be set in 50-mm increments)	50-600mm	50-200mm
Max speed	HH type: 400mm/s HM type: 250mm/s	High-speed type: 600mm/s Medium-speed type: 300mm/s
Motor size	42-square pulse motor	
Ball screw lead	High-speed type: 12mm	High-speed type: 12mm Medium-speed type: 6mm
Drive method	Ball screw, $\phi$ 10 mm, rolled, C10	
Positioning repeatability	$\pm$ 0.02mm	
Base material	Dedicated alloy steel	Aluminum
Surrounding air temperature/humidity	0 to 40°C, 85% RH or below (non-condensing)	

Dimensions

You can download CAD drawings from our website.

www.intelligentactuator.com

2D CAD

Note 1. The connected position shown in the drawing defines the home.  
 Note 2. Both wiring 1 and wiring 2 assume use of a cable track.  
 Note 3. For details on the cable track, refer to P. 90.  
 Note 4. For details on the bracket on the moving end of the cable track, refer to P. 90.

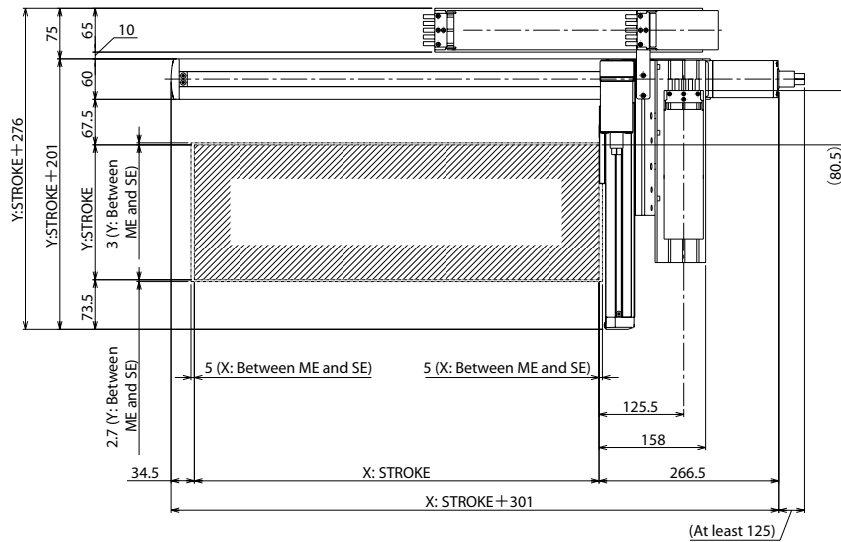
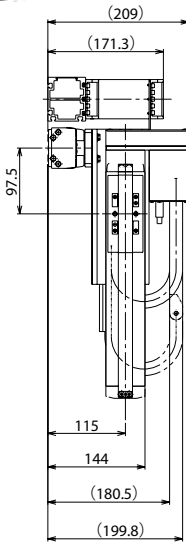

31  
(Tolerance for reamed hole pitch: ±0.02)

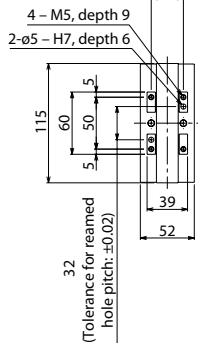

ME: Mechanical end  
 SE: Stroke end

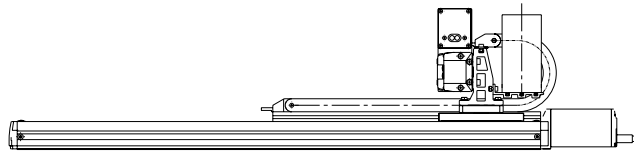

Detail view of Y-axis slider



Detail view of slot in bottom face of X-axis base

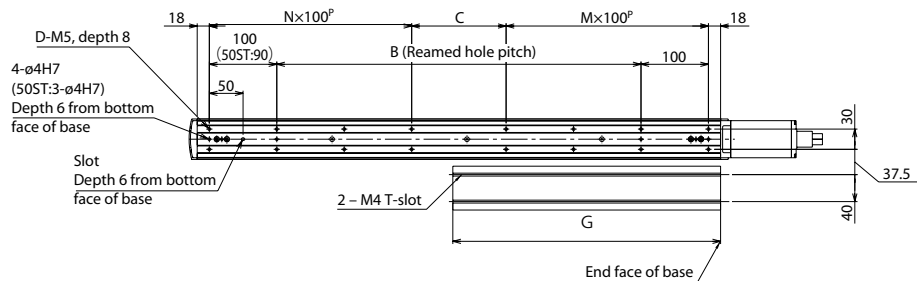

Detail view of X-axis installation

■ Dimensions by Stroke

X: Model	50	100	150	200	250	300	350	400	450	500	550	600
B	0	40	90	140	190	240	290	340	390	440	490	540
C	90	40	90	140	190	40	90	140	190	40	90	140
D	6	8	8	8	8	12	12	12	12	16	16	16
M	1	1	1	1	1	2	2	2	2	3	3	3
N	0	1	1	1	1	2	2	2	2	3	3	3
G	122	147	172	197	222	247	272	297	322	347	372	397

Controllers

Applicable controller



Refer to P. 91 for the controllers.

# IK2-PXBC2□□D

RCP2 2-axis Combinations X axis: SS7C (Straight, Double-slider)  
Y axis: SA6R (Reversed)

**Model Details**

Series: **IK2** Type: **PXBC2□□D** Encoder type: **□** Axis 1 (X axis): **□** Axis 2 (Y axis): **□** Controllers: **P1** Cable: **□** Shipping configuration: **□**

**Combination directions** 1-4

**Differences between Single-slider and Double-slider Types**  
HH: X high-speed, Y high-speed  
HM: X high-speed, Y medium-speed

**Encoder type**  
I: Incremental

**Stroke (mm)**  
5: 50mm  
(Can be set in 50-mm increments)

**Options**  
NM: Opposite-home specification  
SR: Slider roller specification

**Cable length**  
1L: 1m  
3L: 3m  
5L: 5m  
□L: □m

**Wiring 1**  
N: Cable only

**Wiring 2**  
CT: With cable track

**Shipping configuration**  
K: Individual components (kit)

\* Refer to P.10 for details on the items comprising the model name.

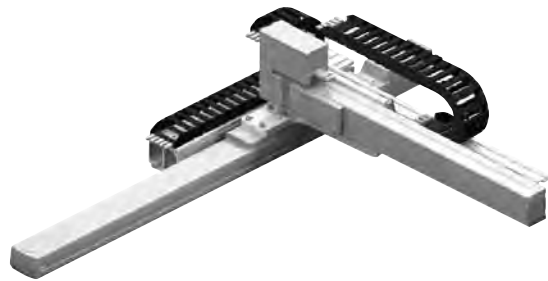

**Maximum Stroke**

X axis 450 mm Y axis 400 mm

**Maximum Speed (High-speed type)**

X axis 400 mm/s Y axis 600 mm/s

**Maximum Load Capacity**

Y-axis stroke	X high-speed, Y high-speed	X high-speed, Y medium-speed
250mm	3.0kg	6.0kg
300mm	3.0kg	6.0kg
350mm	3.0kg	6.0kg
400mm	3.0kg	6.0kg

Both wiring 1 and wiring 2 assume use of a cable track.

**List by Stroke**

		Incremental			
Y-axis stroke		250	300	350	400
X-axis stroke	50	-	-	-	-
	100	-	-	-	-
	150	-	-	-	-
	200	-	-	-	-
	250	-	-	-	-
	300	-	-	-	-
	350	-	-	-	-
	400	-	-	-	-
	450	-	-	-	-

**Cable track**

Wiring 1 (Next to X-axis)	X-axis stroke	50-300	350-450
			-
Wiring 2 (Next to Y-axis)	Y-axis stroke	250-400	-
			-

**List by Cable Length**

Type	Cable code	Length
Standard type	1L	1m
	3L	3m
	5L	5m

\* Axis 1 comes with a standard cable, while axis 2 comes with a robot cable.

\* Refer to P. 90 for lengths other than those specified above.

**List of Options**

Name	Option code	
Opposite-home specification	NM	
Slider roller specification	SR	Axis 1 (X-axis) Axis 2 (Y-axis)

**Specifications**

Item	X axis	Y axis
Axis model	RCP2-SS7C	RCP2-SA6R
Stroke (Can be set in 50-mm increments)	50-450mm	250-400mm
Max speed	HH type: 400mm/s HM type: 250mm/s	High-speed type: 600mm/s Medium-speed type: 300mm/s
Motor size	42-square pulse motor	
Ball screw lead	High-speed type: 12mm	High-speed type: 12mm Medium-speed type: 6mm
Drive method	Ball screw, ø10 mm, rolled, C10	
Positioning repeatability	±0.02mm	
Base material	Dedicated alloy steel	Aluminum
Surrounding air temperature/humidity	0 to 40°C, 85% RH or below (non-condensing)	



Dimensions

You can download CAD drawings from our website.

[www.intelligentactuator.com](http://www.intelligentactuator.com)

2D CAD

Note 1. The connected position shown in the drawing defines the home.  
 Note 2. Both wiring 1 and wiring 2 assume use of a cable track.  
 Note 3. For details on the cable track, refer to P.90.  
 Note 4. For details on the bracket on the moving end of the cable track, refer to P.90.

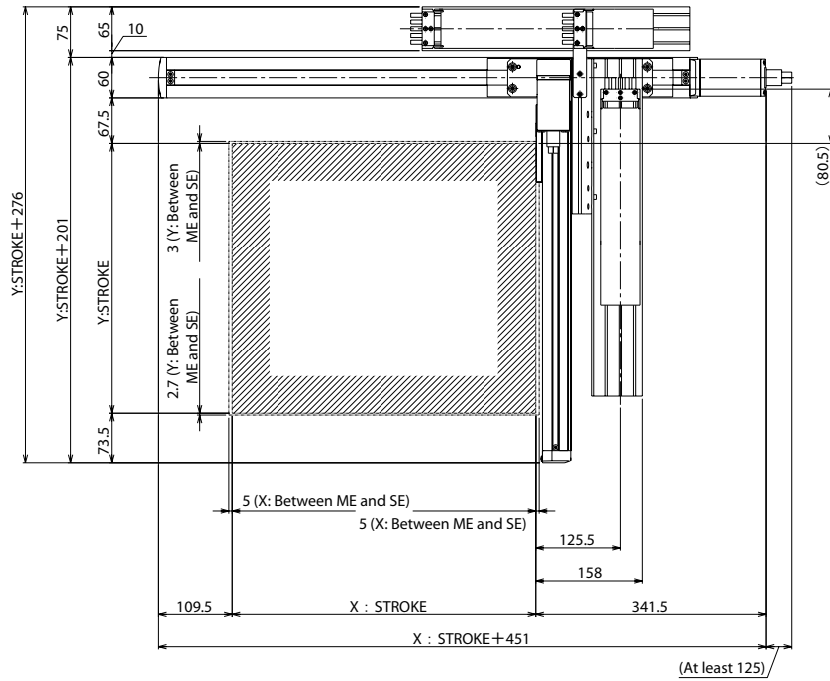
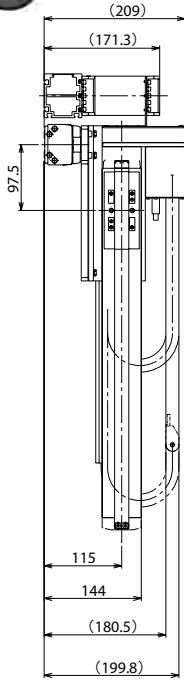

ME: Mechanical end  
 SE: Stroke end

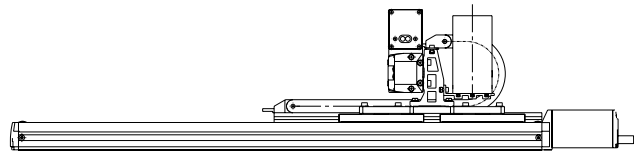

31  
 (Tolerance for reamed hole pitch: ±0.02)

4 - M5, depth 9  
 2 - Ø5 - H7, depth 6

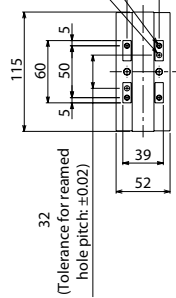

Detail view of Y-axis slider



Detail view of slot in bottom face of X-axis base

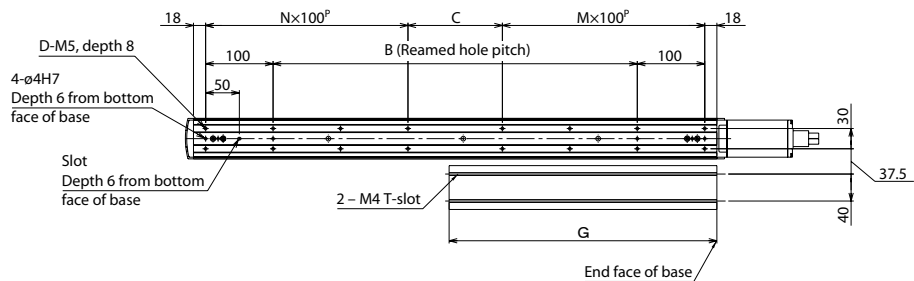

Detail view of X-axis installation

■ Dimensions by Stroke

X: Nominal stroke	200	250	300	350	400	450	500	550	600
X: Effective stroke	50	100	150	200	250	300	350	400	450
B	140	190	240	290	340	390	440	490	540
C	140	190	40	90	140	190	40	90	140
D	8	8	12	12	12	12	16	16	16
M	1	1	2	2	2	2	3	3	3
N	1	1	2	2	2	2	3	3	3
G	197	222	247	272	297	322	347	372	397

Controllers

Applicable controller



Refer to P. 91 for the controllers.

# IK2-PXBB1□□S

RCP2 2-axis Combinations X axis: SS8R (Reversed, Single-slider)  
Y axis: SA7R (Reversed)

**Model Details**

Series: **IK2** — Type: **PXBB1□□S** — Encoder type: **I** — Axis 1 (X axis): **□** — Axis 2 (Y axis): **□** — Controllers: **P1** — Cable: **□** — Shipping configuration: **□**

**Combination directions 1-2**: Differences between Single-slider and Double-slider Types  
 HH: X high-speed, Y high-speed  
 MM: X medium-speed, Y medium-speed

**Encoder type I**: Incremental

**Stroke (mm)**: 5: 50mm  
 ? (Can be set in 50-mm increments)

**Options**:  
 NM: Opposite-home specification  
 SR: Slider roller specification

**Cable length**:  
 1L: 1m  
 3L: 3m  
 5L: 5m  
 □L: □m

**Wiring 1**: N: Cable only  
 CT: With cable track

**Wiring 2**: N: Cable only  
 CT: With cable track

**Shipping configuration K**: Individual components (kit)

\* Refer to P.10 for details on the items comprising the model name.

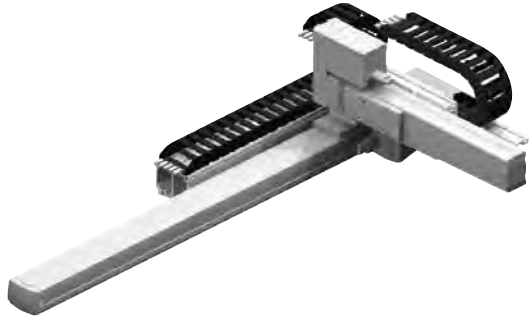

**Maximum Stroke**

X axis 1000 mm

Y axis 300 mm

**Maximum Speed (High-speed type)**

X axis 250 mm/s

Y axis 450 mm/s

**Maximum Load Capacity**

Y-axis stroke	X high-speed, Y high-speed	X medium-speed, Y medium-speed
50mm	8.0kg	16kg
100mm	8.0kg	16kg
150mm	7.0kg	15kg
200mm	7.0kg	12.5kg
250mm	6.0kg	9.0kg
300mm	6.0kg	8.0kg

Both wiring 1 and wiring 2 assume use of a cable track.

**List by Stroke**

		Incremental					
Y-axis stroke		50	100	150	200	250	300
X-axis stroke	50	-	-	-	-	-	-
	100	-	-	-	-	-	-
	150	-	-	-	-	-	-
	200	-	-	-	-	-	-
	250	-	-	-	-	-	-
	300	-	-	-	-	-	-
	350	-	-	-	-	-	-
	400	-	-	-	-	-	-
	450	-	-	-	-	-	-
	500	-	-	-	-	-	-
	550	-	-	-	-	-	-
	600	-	-	-	-	-	-
	650	-	-	-	-	-	-
	700	-	-	-	-	-	-
	750	-	-	-	-	-	-
	800	-	-	-	-	-	-
	850	-	-	-	-	-	-
900	-	-	-	-	-	-	
950	-	-	-	-	-	-	
1000	-	-	-	-	-	-	

**Cable track**

Wiring 1 (Next to X-axis)	X-axis stroke	50-300	350-600	650-900	950-1000
	Y-axis stroke	50-200	250-300	-	-
Wiring 2 (Next to Y-axis)					

**List by Cable Length**

Type	Cable code	Length
Standard type	1L	1m
	3L	3m
	5L	5m

\* Axis 1 comes with a standard cable, while axis 2 comes with a robot cable.  
 \* Refer to P. 90 for lengths other than those specified above.

**List of Options**

Name	Option code	
Opposite-home specification	NM	
Slider roller specification	SR	Axis 1 (X-axis) Axis 2 (Y-axis)

**Specifications**

Item	X axis	Y axis
Axis model	RCP2-SS8R	RCP2-SA7R
Stroke (Can be set in 50-mm increments)	50-1000mm	50-300mm
Max speed	High-speed type: 250mm/s Medium-speed type: 125mm/s	High-speed type: 450mm/s Medium-speed type: 220mm/s
Motor size	56-square pulse motor	
Ball screw lead	High-speed type: 20mm Medium-speed type: 10mm	High-speed type: 16mm Medium-speed type: 8mm
Drive method	Ball screw, ø16mm, rolled, C10	Ball screw, ø12mm, rolled, C10
Positioning repeatability	±0.02mm	
Base material	Dedicated alloy steel	Aluminum
Surrounding air temperature/humidity	0 to 40°C, 85% RH or below (non-condensing)	

Dimensions

You can download CAD drawings from our website.

[www.intelligentactuator.com](http://www.intelligentactuator.com)

2D CAD

- Note 1. The connected position shown in the drawing defines the home.
- Note 2. Both wiring 1 and wiring 2 assume use of a cable track.
- Note 3. For details on the cable track, refer to P.90.
- Note 4. For details on the bracket on the moving end of the cable track, refer to P.90.

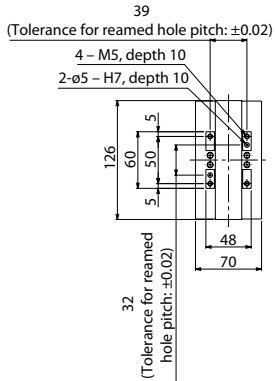
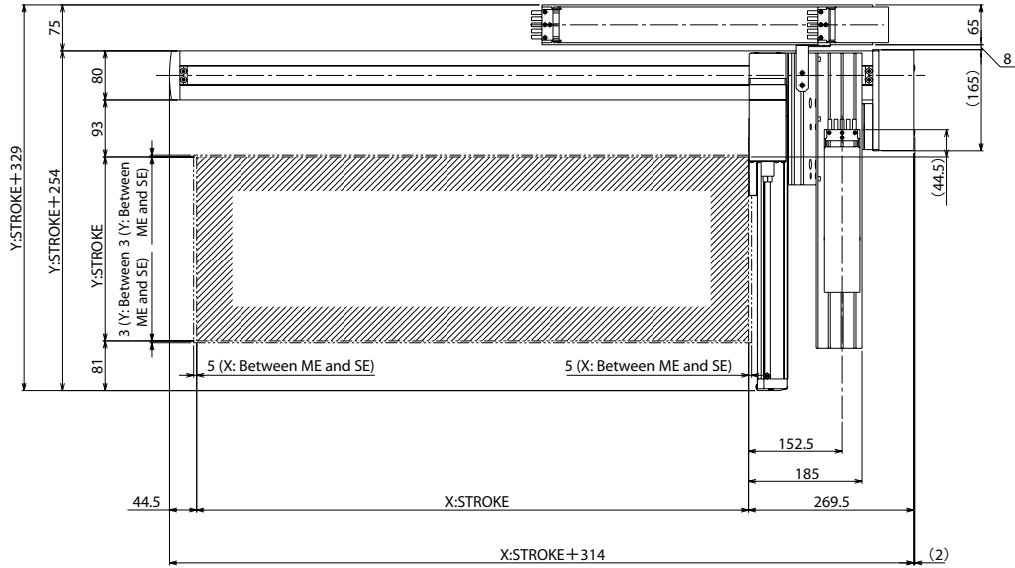
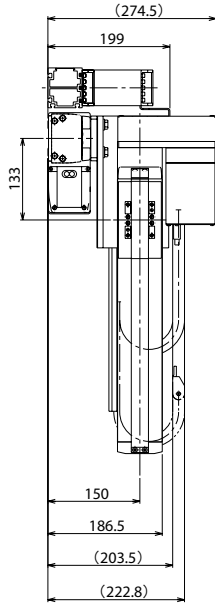

ME: Mechanical end  
SE: Stroke end

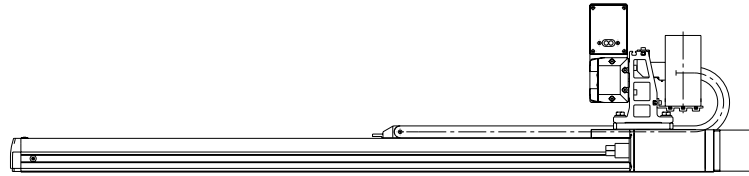

Detail view of Y-axis slider

Detail view of slot in bottom face of X-axis base



D-M8, depth 10  
4-Ø 5H7  
Depth 6 from bottom face of base  
Slot  
Depth 6 from bottom face of base

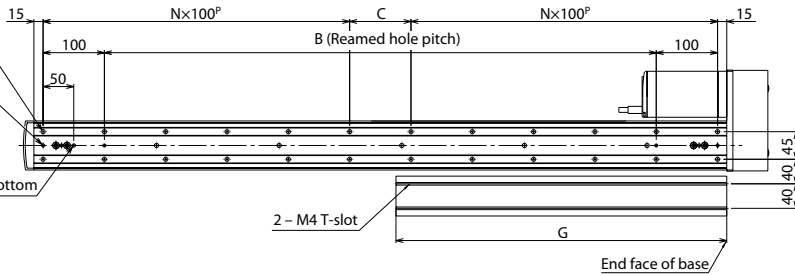

Detail view of X-axis installation

Dimensions by Stroke

X: Model	50	100	150	200	250	300	350	400	450	500	550	600	650	700	750	800	850	900	950	1000
B	50	100	150	200	250	300	350	400	450	500	550	600	650	700	750	800	850	900	950	1000
C	50	100	150	0	50	100	150	0	50	100	150	0	50	100	150	0	50	100	150	0
D	8	8	8	10	12	12	12	14	16	16	16	18	20	20	20	22	24	24	24	26
N	1	1	1	2	2	2	2	3	3	3	3	4	4	4	4	5	5	5	5	6
G	114.5	139.5	164.5	189.5	214.5	239.5	264.5	289.5	314.5	339.5	364.5	389.5	414.5	439.5	464.5	489.5	514.5	539.5	564.5	589.5

Controllers

Applicable controller



Refer to P. 91 for the controllers.

# IK2-PXBB1□□D

RCP2 2-axis Combinations X axis: SS8R (Reversed, Double-slider)  
Y axis: SA7R (Reversed)

**Model Details**

Series: **IK2** | Type: **PXBB1□□D** | Encoder type:  | Axis 1 (X axis):  | Axis 2 (Y axis):  | Controllers: **P1** | Cable:  | Shipping configuration:

**Combination directions 1-2**  
Differences between Single-slider and Double-slider Types  
HH: X high-speed, Y high-speed  
MM: X medium-speed, Y medium-speed

**Encoder type**  
I: Incremental

**Stroke (mm)**  
5: 50mm  
(Can be set in 50-mm increments)

**Options**  
NM: Opposite-home specification  
SR: Slider roller specification

**Cable length**  
1L: 1m  
3L: 3m  
5L: 5m  
□L: □m

**Wiring 1**  
N: Cable only  
CT: With cable track

**Wiring 2**

**Shipping configuration**  
K: Individual components (kit)

\* Refer to P.10 for details on the items comprising the model name.

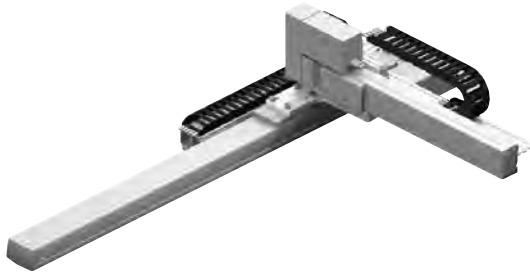

**Maximum Stroke**

X axis 800 mm

Y axis 400 mm

**Maximum Speed (High-speed type)**

X axis 250 mm/s

Y axis 450 mm/s

**Maximum Load Capacity**

Y-axis stroke	X high-speed, Y high-speed	X medium-speed, Y medium-speed
200mm	–	15kg
250mm	–	12.5kg
300mm	–	12.5kg
350mm	6.0kg	12kg
400mm	5.5kg	10.5kg

Both wiring 1 and wiring 2 assume use of a cable track.

**List by Stroke**

		Incremental				
Y-axis stroke		200	250	300	350	400
X-axis stroke	50	–	–	–	–	–
	100	–	–	–	–	–
	150	–	–	–	–	–
	200	–	–	–	–	–
	250	–	–	–	–	–
	300	–	–	–	–	–
	350	–	–	–	–	–
	400	–	–	–	–	–
	450	–	–	–	–	–
	500	–	–	–	–	–
	550	–	–	–	–	–
	600	–	–	–	–	–
	650	–	–	–	–	–
	700	–	–	–	–	–
	750	–	–	–	–	–
	800	–	–	–	–	–

Note: For the X high-speed/Y high-speed type, the Y-axis stroke must be 350 mm or more.

**Cable track**

Wiring 1 (Next to X-axis)	X-axis stroke	50-300	350-600	650-800
Wiring 2 (Next to Y-axis)	Y-axis stroke	200	250-400	–
				–

**List by Cable Length**

Type	Cable code	Length
Standard type	1L	1m
	3L	3m
	5L	5m

\* Axis 1 comes with a standard cable, while axis 2 comes with a robot cable.  
\* Refer to P.90 for lengths other than those specified above.

**List of Options**

Name	Option code	
Opposite-home specification	<b>NM</b>	
Slider roller specification	<b>SR</b>	Axis 1 (X-axis) Axis 2 (Y-axis)

**Specifications**

Item	X axis	Y axis
Axis model	RCP2-SS8R	RCP2-SA7R
Stroke (Can be set in 50-mm increments)	50-800mm	High-speed type: 350-400mm Medium-speed type: 200-400mm
Max speed	High-speed type: 250mm/s Medium-speed type: 125mm/s	High-speed type: 450mm/s Medium-speed type: 220mm/s
Motor size	56-square pulse motor	
Ball screw lead	High-speed type: 20mm Medium-speed type: 10mm	High-speed type: 16mm Medium-speed type: 8mm
Drive method	Ball screw, ø16mm, rolled, C10	Ball screw, ø12mm, rolled, C10
Positioning repeatability	±0.02mm	
Base material	Dedicated alloy steel	Aluminum
Surrounding air temperature/humidity	0 to 40°C, 85% RH or below (non-condensing)	

Dimensions

You can download CAD drawings from our website.

[www.intelligentactuator.com](http://www.intelligentactuator.com)

2D CAD

- Note 1. The connected position shown in the drawing defines the home.
- Note 2. Both wiring 1 and wiring 2 assume use of a cable track.
- Note 3. For details on the cable track, refer to P.90.
- Note 4. For details on the bracket on the moving end of the cable track, refer to P.90.

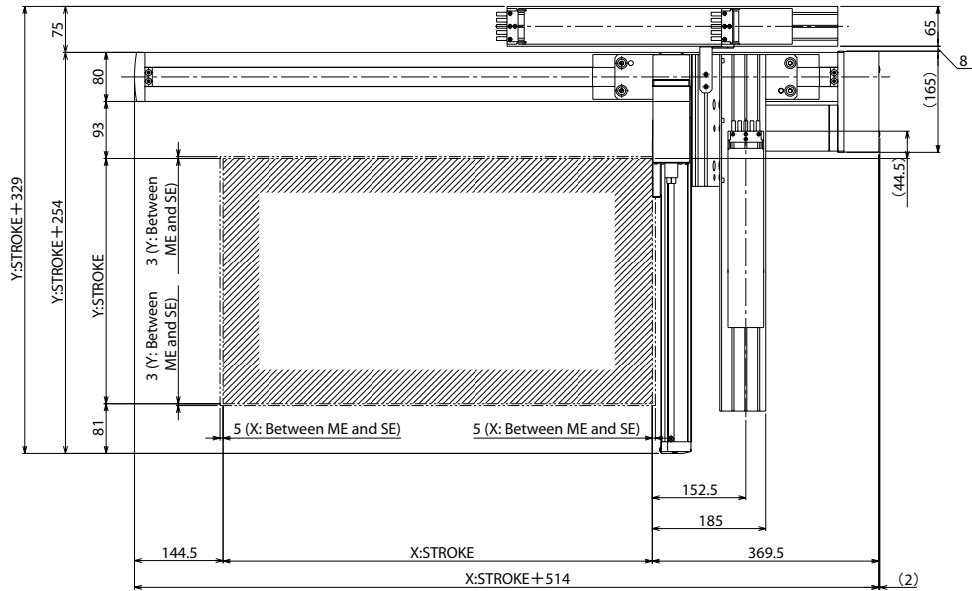
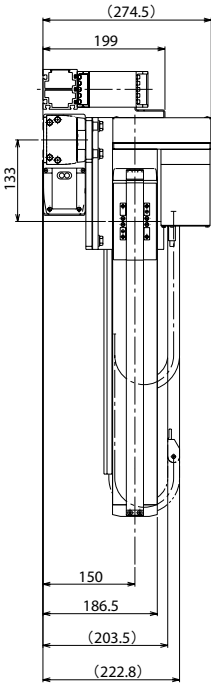

ME: Mechanical end  
SE: Stroke end

39  
(Tolerance for reamed hole pitch: ±0.02)

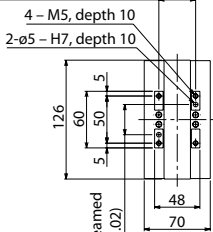

Detail view of Y-axis slider



Detail view of slot in bottom face of X-axis base

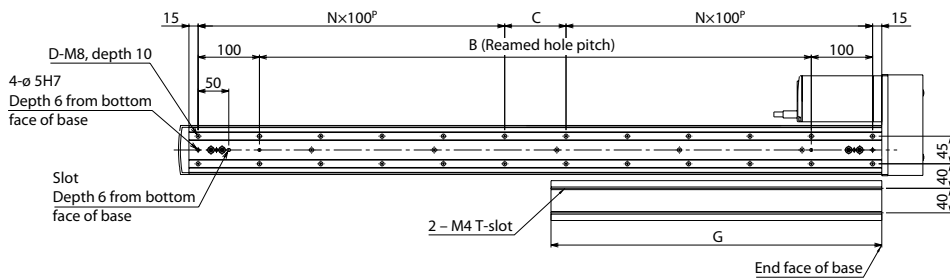
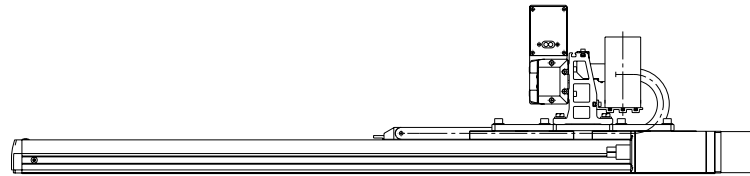

Detail view of X-axis installation

■ Dimensions by Stroke

X: Nominal stroke	250	300	350	400	450	500	550	600	650	700	750	800	850	900	950	1000
X: Effective stroke	50	100	150	200	250	300	350	400	450	500	550	600	650	700	750	800
B	250	300	350	400	450	500	550	600	650	700	750	800	850	900	950	1000
C	50	100	150	0	50	100	150	0	50	100	150	0	50	100	150	0
D	12	12	12	14	16	16	16	18	20	20	20	22	24	24	24	26
N	2	2	2	3	3	3	3	4	4	4	4	5	5	5	5	6
G	214.5	239.5	264.5	289.5	314.5	339.5	364.5	389.5	414.5	439.5	464.5	489.5	514.5	539.5	564.5	589.5

Controllers

Applicable controller



Refer to P. 91 for the controllers.

# IK2-PXBB2□□S

RCP2 2-axis Combinations X axis: SS8C (Straight, Single-slider)  
Y axis: SA7R (Reversed)

**Model Details**

Series: **IK2** | Type: **PXBB2□□S** | Encoder type: **I** | Axis 1 (X axis): **□** | Axis 2 (Y axis): **□** | Controllers: **P1** | Cable: **□** | Shipping configuration: **□**

**Combination directions** 1-4

**Differences between Single-slider and Double-slider Types**  
 HH: X high-speed, Y high-speed  
 MM: X medium-speed, Y medium-speed

**Encoder type**  
 I: Incremental

**Stroke (mm)**  
 5: 50mm  
 }  
 (Can be set in 50-mm increments)

**Options**  
 NM: Opposite-home specification  
 SR: Slider roller specification

**Cable length**  
 1L: 1m  
 3L: 3m  
 5L: 5m  
 □L: □m

**Wiring 1**  
 N: Cable only  
 CT: With cable track

**Wiring 2**

**Shipping configuration**  
 K: Individual components (kit)

\* Refer to P.10 for details on the items comprising the model name.

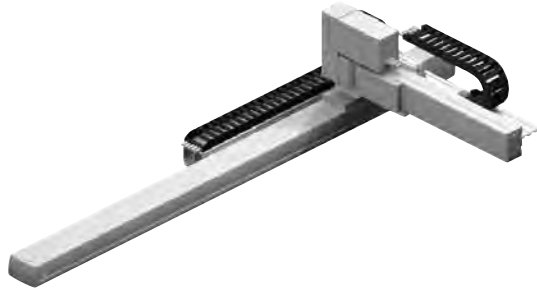

**Maximum Stroke**

X axis 1000 mm

Y axis 300 mm

**Maximum Speed (High-speed type)**

X axis 250 mm/s

Y axis 450 mm/s

**Maximum Load Capacity**

Y-axis stroke	X high-speed, Y high-speed	X medium-speed, Y medium-speed
50mm	8.0kg	16kg
100mm	8.0kg	16kg
150mm	7.0kg	15kg
200mm	7.0kg	12.5kg
250mm	6.0kg	9.0kg
300mm	6.0kg	8.0kg

Both wiring 1 and wiring 2 assume use of a cable track.

**List by Stroke**

		Incremental					
Y-axis stroke		50	100	150	200	250	300
X-axis stroke	50	-	-	-	-	-	-
	100	-	-	-	-	-	-
	150	-	-	-	-	-	-
	200	-	-	-	-	-	-
	250	-	-	-	-	-	-
	300	-	-	-	-	-	-
	350	-	-	-	-	-	-
	400	-	-	-	-	-	-
	450	-	-	-	-	-	-
	500	-	-	-	-	-	-
	550	-	-	-	-	-	-
	600	-	-	-	-	-	-
	650	-	-	-	-	-	-
	700	-	-	-	-	-	-
	750	-	-	-	-	-	-
	800	-	-	-	-	-	-
	850	-	-	-	-	-	-
900	-	-	-	-	-	-	
950	-	-	-	-	-	-	
1000	-	-	-	-	-	-	

**Cable track**

Wiring 1 (Next to X-axis)	X-axis stroke	50-300	350-600	650-900	950-1000
	Y-axis stroke	50-200	250-300	-	-
Wiring 2 (Next to Y-axis)					

**List by Cable Length**

Type	Cable code	Length
Standard type	1L	1m
	3L	3m
	5L	5m

\* Axis 1 comes with a standard cable, while axis 2 comes with a robot cable.

\* Refer to P. 90 for lengths other than those specified above.

**List of Options**

Name	Option code	
Opposite-home specification	NM	
Slider roller specification	SR	Axis 1 (X-axis) Axis 2 (Y-axis)

**Specifications**

Item	X axis	Y axis
Axis model	RCP2-SS8C	RCP2-SA7R
Stroke (Can be set in 50-mm increments)	50-1000mm	50-300mm
Max speed	High-speed type: 250mm/s Medium-speed type: 125mm/s	High-speed type: 450mm/s Medium-speed type: 220mm/s
Motor size	56-square pulse motor	
Ball screw lead	High-speed type: 20mm Medium-speed type: 10mm	High-speed type: 16mm Medium-speed type: 8mm
Drive method	Ball screw, ø16mm, rolled, C10	Ball screw, ø12mm, rolled, C10
Positioning repeatability	±0.02mm	
Base material	Dedicated alloy steel	Aluminum
Surrounding air temperature/humidity	0 to 40°C, 85% RH or below (non-condensing)	



Dimensions

You can download CAD drawings from our website.

[www.intelligentactuator.com](http://www.intelligentactuator.com)

2D CAD

- Note 1. The connected position shown in the drawing defines the home.
- Note 2. Both wiring 1 and wiring 2 assume use of a cable track.
- Note 3. For details on the cable track, refer to P.90.
- Note 4. For details on the bracket on the moving end of the cable track, refer to P.90.

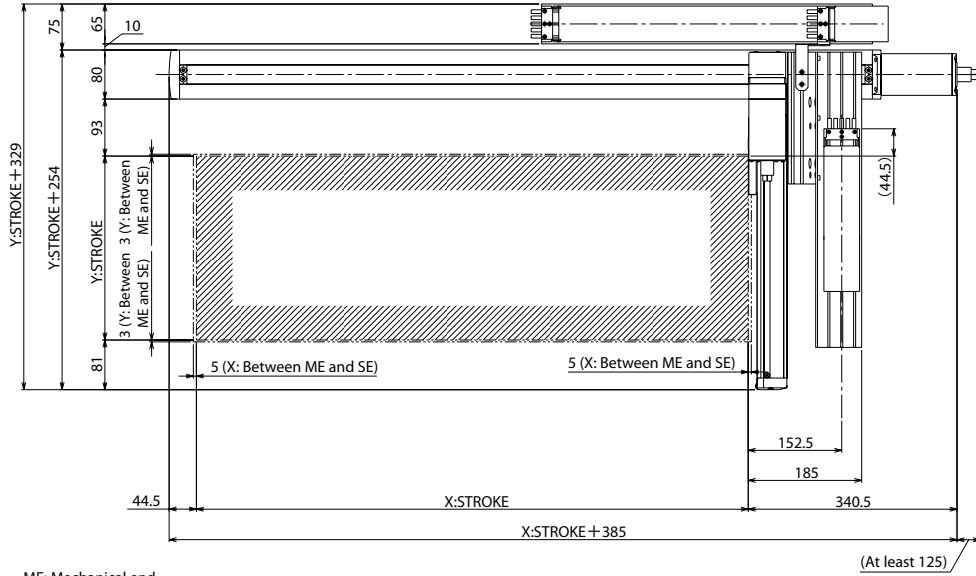
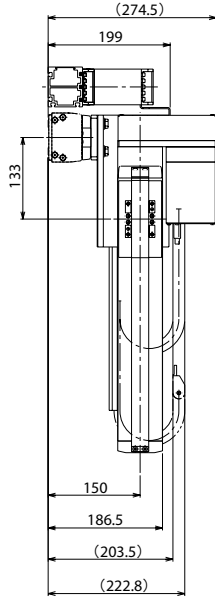

ME: Mechanical end  
SE: Stroke end

39  
(Tolerance for reamed hole pitch: ±0.02)

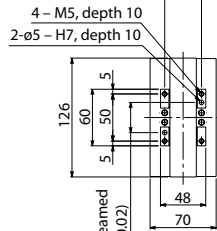

32  
(Tolerance for reamed hole pitch: ±0.02)

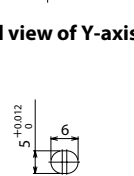

Detail view of Y-axis slider

Detail view of slot in bottom face of X-axis base

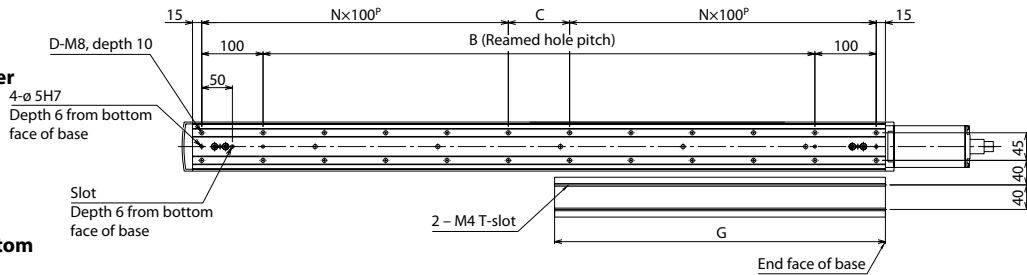
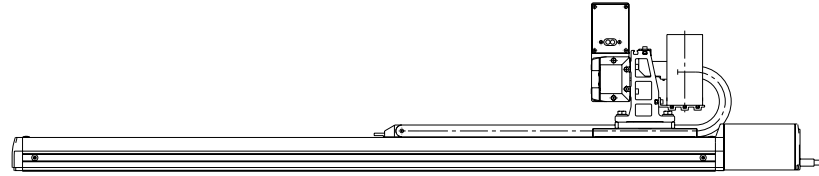

Detail view of X-axis installation

Dimensions by Stroke

X: Model	50	100	150	200	250	300	350	400	450	500	550	600	650	700	750	800	850	900	950	1000
B	50	100	150	200	250	300	350	400	450	500	550	600	650	700	750	800	850	900	950	1000
C	50	100	150	0	50	100	150	0	50	100	150	0	50	100	150	0	50	100	150	0
D	8	8	8	10	12	12	12	14	16	16	16	18	20	20	20	22	24	24	24	26
N	1	1	1	2	2	2	2	3	3	3	3	4	4	4	4	5	5	5	5	6
G	114.5	139.5	164.5	189.5	214.5	239.5	264.5	289.5	314.5	339.5	364.5	389.5	414.5	439.5	464.5	489.5	514.5	539.5	564.5	589.5

Controllers

Applicable controller



Refer to P. 91 for the controllers.

# IK2-PXBB2□□D

RCP2 2-axis Combinations X axis: SS8C (Straight, Double-slider)  
Y axis: SA7R (Reversed)

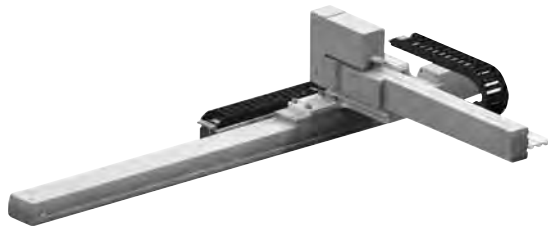
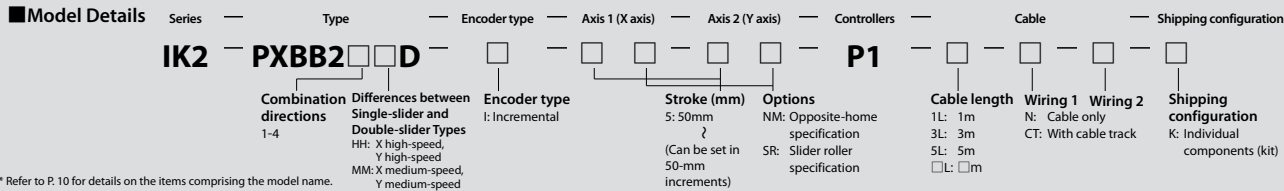

**Maximum Stroke**

X axis 800 mm    Y axis 400 mm

**Maximum Speed (High-speed type)**

X axis 250 mm/s    Y axis 450 mm/s

**Maximum Load Capacity**

Y-axis stroke	X high-speed, Y high-speed	X medium-speed, Y medium-speed
200mm	–	15kg
250mm	–	12.5kg
300mm	–	12.5kg
350mm	6.0kg	12kg
400mm	5.5kg	10.5kg

Both wiring 1 and wiring 2 assume use of a cable track.

**List by Stroke**

		Incremental				
Y-axis stroke		200	250	300	350	400
X-axis stroke	50	–	–	–	–	–
	100	–	–	–	–	–
	150	–	–	–	–	–
	200	–	–	–	–	–
	250	–	–	–	–	–
	300	–	–	–	–	–
	350	–	–	–	–	–
	400	–	–	–	–	–
	450	–	–	–	–	–
	500	–	–	–	–	–
	550	–	–	–	–	–
	600	–	–	–	–	–
	650	–	–	–	–	–
	700	–	–	–	–	–
	750	–	–	–	–	–
	800	–	–	–	–	–

Note: For the X high-speed/Y high-speed type, the Y-axis stroke must be 350 mm or more.

**Cable track**

Wiring 1 (Next to X-axis)	X-axis stroke	50-300	350-600	650-800
Wiring 2 (Next to Y-axis)	Y-axis stroke	200	250-400	–
				–

**List by Cable Length**

Type	Cable code	Length
Standard type	1L	1m
	3L	3m
	5L	5m

\* Axis 1 comes with a standard cable, while axis 2 comes with a robot cable.  
\* Refer to P. 90 for lengths other than those specified above.

**List of Options**

Name	Option code	
Opposite-home specification	NM	
Slider roller specification	SR	Axis 1 (X-axis) Axis 2 (Y-axis)

**Specifications**

Item	X axis	Y axis
Axis model	RCP2-SS8C	RCP2-SA7R
Stroke (Can be set in 50-mm increments)	50-800mm	High-speed type: 350-400mm Medium-speed type: 200-400mm
Max speed	High-speed type: 250mm/s Medium-speed type: 125mm/s	High-speed type: 450mm/s Medium-speed type: 220mm/s
Motor size	56-square pulse motor	
Ball screw lead	High-speed type: 20mm Medium-speed type: 10mm	High-speed type: 16mm Medium-speed type: 8mm
Drive method	Ball screw, ø16mm, rolled, C10	Ball screw, ø12mm, rolled, C10
Positioning repeatability	±0.02mm	
Base material	Dedicated alloy steel	Aluminum
Surrounding air temperature/humidity	0 to 40°C, 85% RH or below (non-condensing)	

Dimensions

You can download CAD drawings from our website.

[www.intelligentactuator.com](http://www.intelligentactuator.com)

2D CAD

- Note 1. The connected position shown in the drawing defines the home.
- Note 2. Both wiring 1 and wiring 2 assume use of a cable track.
- Note 3. For details on the cable track, refer to P. 90.
- Note 4. For details on the bracket on the moving end of the cable track, refer to P. 90.

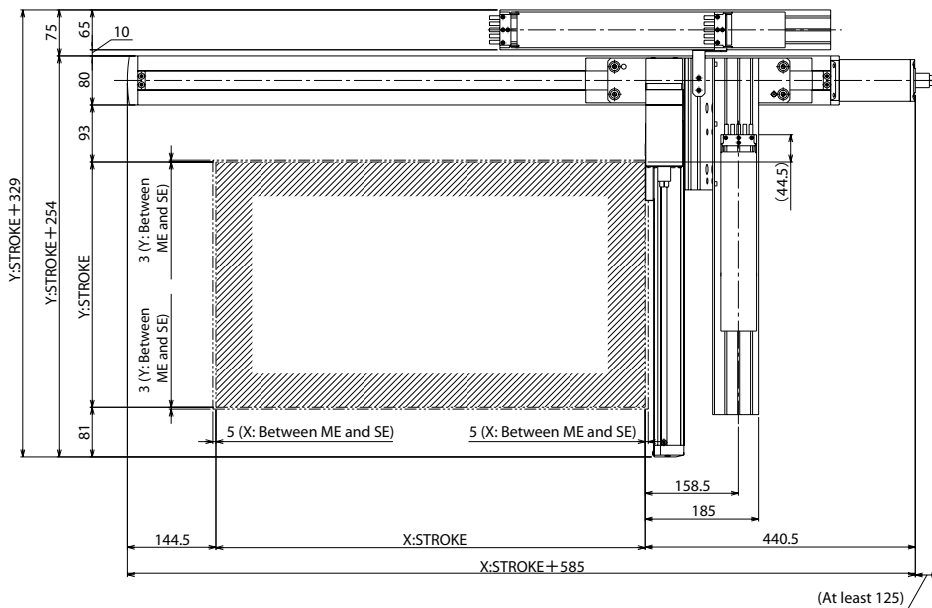
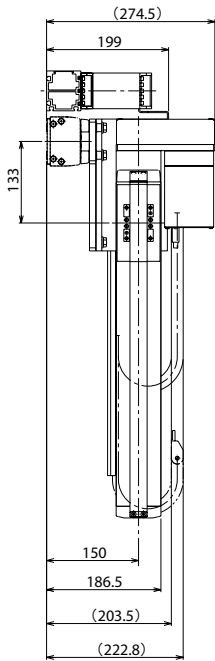

ME: Mechanical end  
SE: Stroke end

39  
(Tolerance for reamed hole pitch: ±0.02)

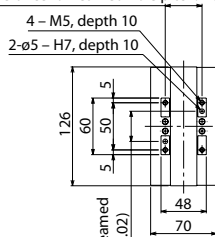

Detail view of Y-axis slider



Detail view of slot in bottom face of X-axis base

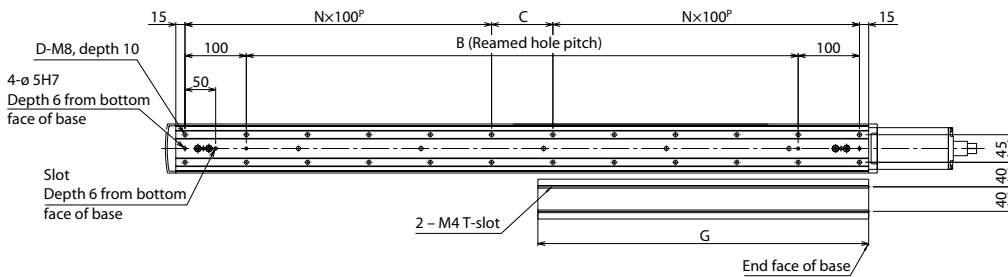
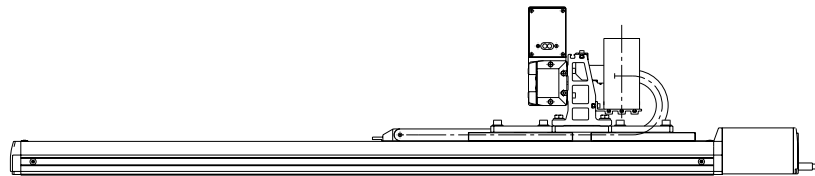

Detail view of X-axis installation

■ Dimensions by Stroke

X: Nominal stroke	250	300	350	400	450	500	550	600	650	700	750	800	850	900	950	1000
X: Effective stroke	50	100	150	200	250	300	350	400	450	500	550	600	650	700	750	800
B	250	300	350	400	450	500	550	600	650	700	750	800	850	900	950	1000
C	50	100	150	0	50	100	150	0	50	100	150	0	50	100	150	0
D	12	12	12	14	16	16	16	18	20	20	20	22	24	24	24	26
N	2	2	2	3	3	3	3	4	4	4	4	5	5	5	5	6
G	214.5	239.5	264.5	289.5	314.5	339.5	364.5	389.5	414.5	439.5	464.5	489.5	514.5	539.5	564.5	589.5

Controllers

Applicable controller



Refer to P. 91 for the controllers.

2-axis  
Combinations  
R C P 2

2-axis  
Combinations  
R C S 2

3-axis  
Combinations  
R C P 2

3-axis  
Combinations  
R C S 2

Controllers

# IK2-PXZB1□□S

RCP2 2-axis Combinations X axis: SS8R (Reversed, Single-slider)  
Z axis: SA7R (Reversed)

**Model Details**

Series: **IK2** Type: **PXZB1□□S** Encoder type: **I** Axis 1 (X axis): **□** Axis 2 (Z axis): **□** Controllers: **P1** Cable: **□** Shipping configuration: **□**

**Combination directions** 1-4

**Differences between Single-slider and Double-slider Types**  
 HH: X high-speed, Z high-speed  
 HM: X high-speed, Z medium-speed  
 HL: X high-speed, Z low-speed

**Encoder type**  
 I: Incremental

**Stroke (mm)**  
 5: 50mm  
 ? (Can be set in 50-mm increments)

**Options**  
 B: Brake  
 NM: Opposite-home specification  
 SR: Slider roller specification

**Cable length**  
 1L: 1m  
 3L: 3m  
 5L: 5m  
 □L: □m

**Wiring 1**  
 N: Cable only  
 CT: With cable track

**Wiring 2**

**Shipping configuration**  
 K: Individual components (kit)

\* Refer to P.10 for details on the items comprising the model name.



Wiring 1 with cable track

**Maximum Stroke**

X axis 1000 mm

Z axis 250 mm

**Maximum Speed (High-speed type)**

X axis 250 mm/s

Z axis 360 mm/s

**Maximum Load Capacity**

Z-axis stroke	Z high-speed, lead 16	Z medium-speed, lead 8	Z low-speed, lead 4
50mm	2.0kg	4.0kg	8.0kg
100mm	2.0kg	4.0kg	7.0kg
150mm	2.0kg	3.5kg	5.0kg
200mm	2.0kg	3.5kg	4.0kg
250mm	1.5kg	2.5kg	3.0kg

**List by Stroke**

Z-axis stroke	Incremental				
	50	100	150	200	250
50	-	-	-	-	-
100	-	-	-	-	-
150	-	-	-	-	-
200	-	-	-	-	-
250	-	-	-	-	-
300	-	-	-	-	-
350	-	-	-	-	-
400	-	-	-	-	-
450	-	-	-	-	-
500	-	-	-	-	-
550	-	-	-	-	-
600	-	-	-	-	-
650	-	-	-	-	-
700	-	-	-	-	-
750	-	-	-	-	-
800	-	-	-	-	-
850	-	-	-	-	-
900	-	-	-	-	-
950	-	-	-	-	-
1000	-	-	-	-	-

**Cable track**

Wiring 1 (Next to X-axis)	X-axis stroke	150-300	350-600	650-900	950-1000

**List by Cable Length**

Type	Cable code	Length
Standard type	1L	1m
	3L	3m
	5L	5m

\* Axis 1 comes with a standard cable, while axis 2 comes with a robot cable.  
 \* Refer to P.90 for lengths other than those specified above.

**List of Options**

Name	Option code	
Opposite-home specification	NM	
Slider roller specification	SR	Axis 1 (X-axis) Axis 2 (Z-axis)

**Specifications**

Item	X axis	Z axis
Axis model	RCP2-SS8R	RCP2-SA7R
Stroke (Can be set in 50-mm increments)	50-1000mm	50-250mm
Max speed	High-speed type: 250mm/s	High-speed type: 360mm/s Medium-speed type: 180mm/s Low-speed type: 90mm/s
Motor size	56-square pulse motor	
Ball screw lead	High-speed type: 20mm	High-speed type: 16mm Medium-speed type: 8mm Low-speed type: 4mm
Drive method	Ball screw, ø16mm, rolled, C10	Ball screw, ø12mm, rolled, C10
Positioning repeatability	±0.02mm	
Base material	Dedicated alloy steel	Aluminum
Surrounding air temperature/humidity	0 to 40°C, 85% RH or below (non-condensing)	

Dimensions

You can download CAD drawings from our website.

[www.intelligentactuator.com](http://www.intelligentactuator.com)

2D CAD

Note 1. The connected position shown in the drawing defines the home.  
 Note 2. Both wiring 1 and wiring 2 assume use of a cable track.  
 Note 3. For details on the cable track, refer to P.90.  
 Note 4. For details on the bracket on the moving end of the cable track, refer to P.90.

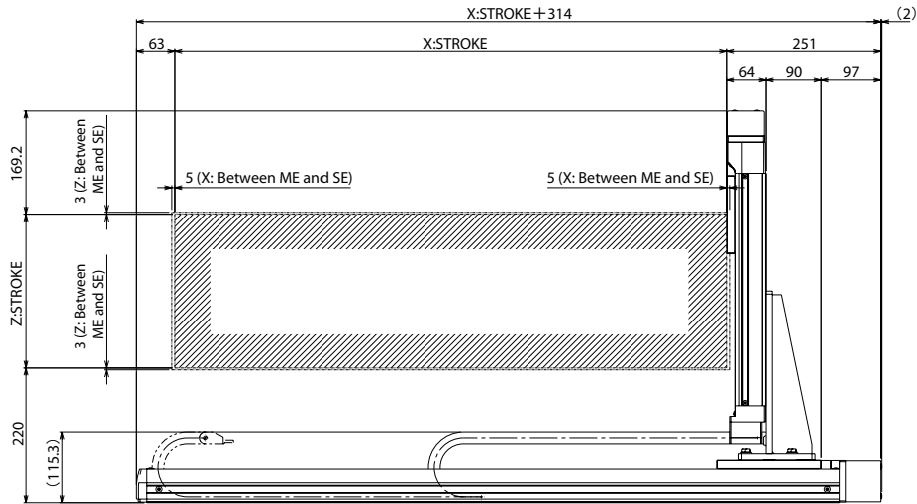
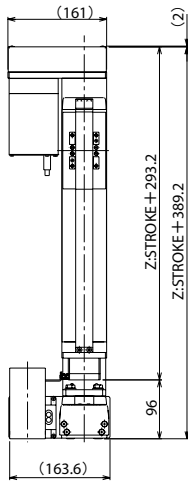
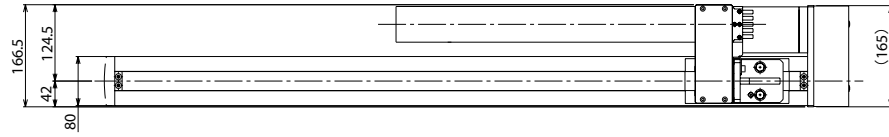

ME: Mechanical end  
 SE: Stroke end

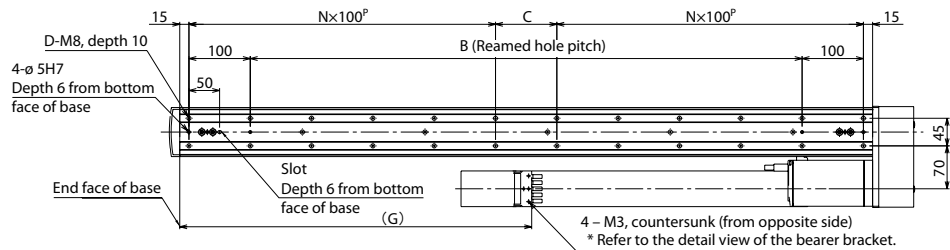
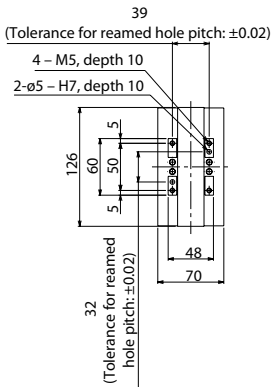

Detail view of X-axis installation

Detail view of Z-axis slider

Detail view of slot in bottom face of X-axis base

Dimensions by Stroke

X: Model	50	100	150	200	250	300	350	400	450	500	550	600	650	700	750	800	850	900	950	1000
B	50	100	150	200	250	300	350	400	450	500	550	600	650	700	750	800	850	900	950	1000
C	50	100	150	0	50	100	150	0	50	100	150	0	50	100	150	0	50	100	150	0
D	8	8	8	10	12	12	12	14	16	16	16	18	20	20	20	22	24	24	24	26
N	1	1	1	2	2	2	2	3	3	3	3	4	4	4	4	5	5	5	5	6
G	-	-	199	224	249	274	299	324	349	374	399	424	449	474	499	524	549	574	599	624

\* A bearer is not set when the X stroke is 50 or 100.

Controllers

Applicable controller



Refer to P. 91 for the controllers.

# IK2-PXZB1□□D

RCP2 2-axis Combinations X axis: SS8R (Reversed, Double-slider)  
Z axis: SA7R (Reversed)

**Model Details**

Series: **IK2** Type: **PXZB1□□D** Encoder type:  Axis 1 (X axis):  Axis 2 (Z axis):  Controllers: **P1** Cable:  Shipping configuration:

**Combination directions** 1-4

**Differences between Single-slider and Double-slider Types**  
HH: X high-speed, Z high-speed  
HM: X high-speed, Z medium-speed  
HL: X high-speed, Z low-speed

**Encoder type**  
I: Incremental

**Stroke (mm)**  
5: 50mm  
(Can be set in 50-mm increments)

**Options**  
B: Brake  
NM: Opposite-home specification  
SR: Slider roller specification

**Cable length**  
1L: 1m  
3L: 3m  
5L: 5m  
L: m

**Wiring 1**  
N: Cable only

**Wiring 2**  
CT: With cable track

**Shipping configuration**  
K: Individual components (kit)

\* Refer to P.10 for details on the items comprising the model name.



Wiring 1 with cable track

**Maximum Stroke**

X axis 800 mm

Z axis 300 mm

**Maximum Speed (High-speed type)**

X axis 250 mm/s

Z axis 400 mm/s

**Maximum Load Capacity**

Z-axis stroke	Z high-speed, lead 16	Z medium-speed, lead 8	Z low-speed, lead 4
150mm	–	–	7.0kg
200mm	–	–	7.0kg
250mm	–	–	5.5kg
300mm	1.5kg	3.0kg	5.5kg

**List by Stroke**

		Incremental			
Z-axis stroke		150	200	250	300
X-axis stroke	50	–	–	–	–
	100	–	–	–	–
	150	–	–	–	–
	200	–	–	–	–
	250	–	–	–	–
	300	–	–	–	–
	350	–	–	–	–
	400	–	–	–	–
	450	–	–	–	–
	500	–	–	–	–
	550	–	–	–	–
	600	–	–	–	–
	650	–	–	–	–
700	–	–	–	–	
750	–	–	–	–	
800	–	–	–	–	

Note: For the Z high-speed type and Z medium-speed type, The Z-axis stroke is limited to 300 mm.

**Cable track**

Wiring 1 (Next to X-axis)	X-axis stroke	150-300	350-600	650-800

**List by Cable Length**

Type	Cable code	Length
Standard type	1L	1m
	3L	3m
	5L	5m

\* Axis 1 comes with a standard cable, while axis 2 comes with a robot cable.

\* Refer to P.90 for lengths other than those specified above.

**List of Options**

Name	Option code	
Opposite-home specification	NM	
Slider roller specification	SR	Axis 1 (X-axis) Axis 2 (Z-axis)

**Specifications**

Item	X axis	Z axis
Axis model	RCP2-SS8R	RCP2-SA7R
Stroke (Can be set in 50-mm increments)	50-800mm	High-speed type: 300mm Medium-speed type: 300mm Low-speed type: 150-300mm
Max speed	High-speed type: 250mm/s	High-speed type: 400mm/s Medium-speed type: 200mm/s Low-speed type: 100mm/s
Motor size	56-square pulse motor	
Ball screw lead	High-speed type: 20mm	High-speed type: 16mm Medium-speed type: 8mm Low-speed type: 4mm
Drive method	Ball screw, ø16mm, rolled, C10	Ball screw, ø12mm, rolled, C10
Positioning repeatability	±0.02mm	
Base material	Dedicated alloy steel	Aluminum
Surrounding air temperature/humidity	0 to 40°C, 85% RH or below (non-condensing)	



Dimensions

You can download CAD drawings from our website.

[www.intelligentactuator.com](http://www.intelligentactuator.com)

2D CAD

Note 1. The connected position shown in the drawing defines the home.  
 Note 2. Both wiring 1 and wiring 2 assume use of a cable track.  
 Note 3. For details on the cable track, refer to P.90.  
 Note 4. For details on the bracket on the moving end of the cable track, refer to P.90.

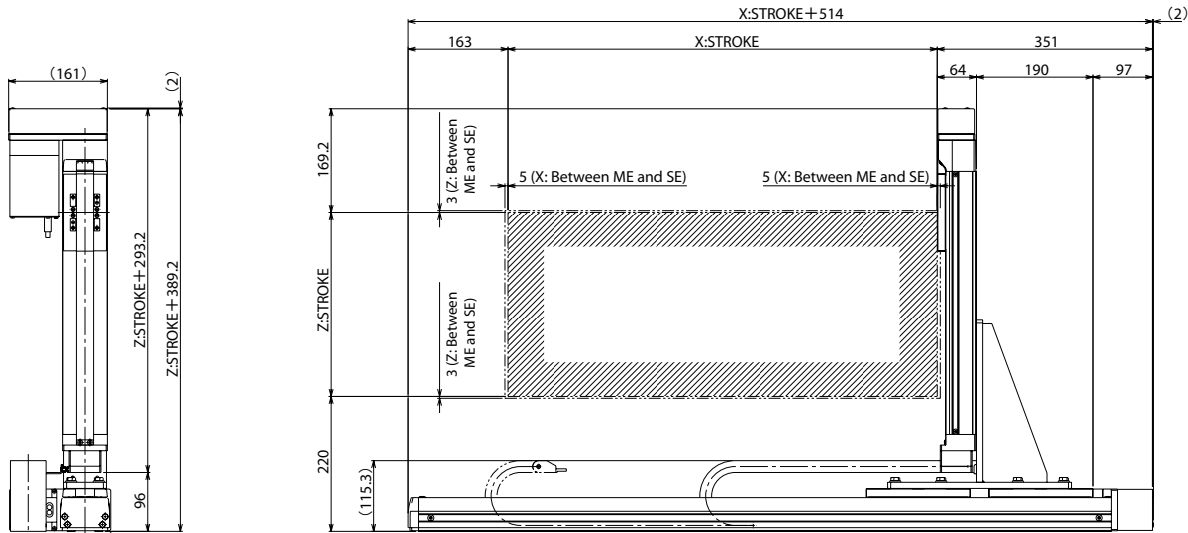
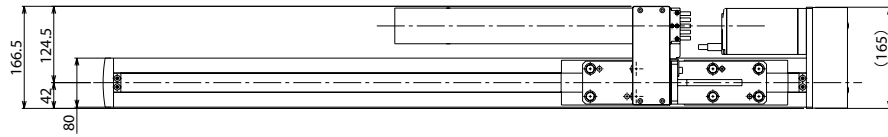

ME: Mechanical end  
 SE: Stroke end

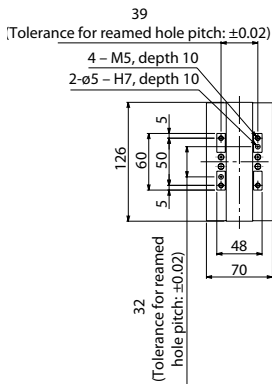

Detail view of Z-axis slider

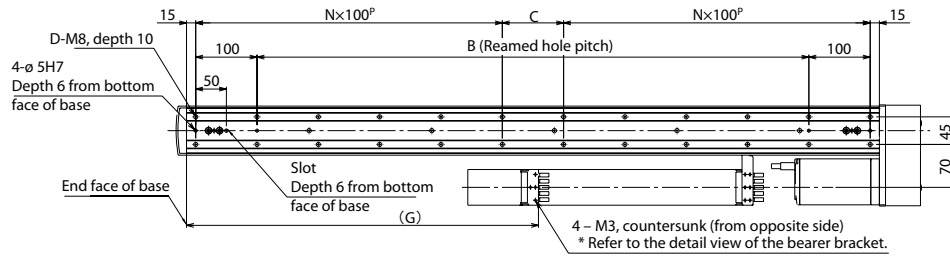

Detail view of X-axis installation



Detail view of slot in bottom face of X-axis base

■ Dimensions by Stroke

X: Nominal stroke	250	300	350	400	450	500	550	600	650	700	750	800	850	900	950	1000
X: Effective stroke	50	100	150	200	250	300	350	400	450	500	550	600	650	700	750	800
B	250	300	350	400	450	500	550	600	650	700	750	800	850	900	950	1000
C	50	100	150	0	50	100	150	0	50	100	150	0	50	100	150	0
D	12	12	12	14	16	16	16	18	20	20	20	22	24	24	24	26
N	2	2	2	3	3	3	3	4	4	4	4	5	5	5	5	6
G	-	-	299	324	349	374	399	424	449	474	499	524	549	574	599	624

\* A bearer is not set when the X stroke is 50 or 100.

Controllers

Applicable controller



Refer to P. 91 for the controllers.

# IK2-PYBB1□□S

RCP2 2-axis Combinations Y axis: SS8R (Reversed, Double-slider)  
Z axis: SA7R (Reversed)

**Model Details**

Series: IK2 — Type: PYBB1□□S — Encoder type: I — Axis 1 (Y axis): — Axis 2 (Z axis): — Controllers: P1 — Cable: — Shipping configuration: K

**Combination directions 1-2**  
Differences between Single-slider and Double-slider Types  
HH: Y high-speed, Z high-speed  
HM: Y high-speed, Z medium-speed  
HL: Y high-speed, Z low-speed

**Encoder type**  
I: Incremental

**Stroke (mm)**  
5: 50mm }  
(Can be set in 50-mm increments)

**Options**  
B: Brake  
NM: Opposite-home specification  
SR: Slider roller specification

**Cable length**  
1L: 1m  
3L: 3m  
5L: 5m  
□L: □m

**Wiring 1**  
N: Cable only  
CT: With cable track

**Wiring 2**

**Shipping configuration**  
K: Individual components (kit)

\* Refer to P.10 for details on the items comprising the model name.

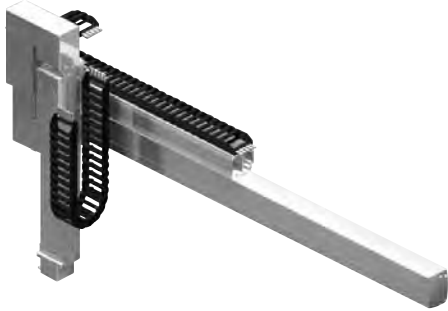

Both wiring 1 and wiring 2 assume use of a cable track.

**Maximum Stroke**

Y axis 1000 mm

Z axis 300 mm

**Maximum Speed (High-speed type)**

Y axis 250 mm/s

Z axis 360 mm/s

**Maximum Load Capacity**

Z-axis stroke	Z high-speed, lead 16	Z medium-speed, lead 8	Z low-speed, lead 4
50mm	2.0kg	4.0kg	8.0kg
100mm	2.0kg	4.0kg	8.0kg
150mm	2.0kg	3.5kg	7.0kg
200mm	2.0kg	3.5kg	7.0kg
250mm	1.5kg	3.0kg	6.0kg
300mm	1.5kg	3.0kg	5.5kg

**List by Stroke**

		Incremental					
Z-axis stroke		50	100	150	200	250	300
Y-axis stroke	50	-	-	-	-	-	-
	100	-	-	-	-	-	-
	150	-	-	-	-	-	-
	200	-	-	-	-	-	-
	250	-	-	-	-	-	-
	300	-	-	-	-	-	-
	350	-	-	-	-	-	-
	400	-	-	-	-	-	-
	450	-	-	-	-	-	-
	500	-	-	-	-	-	-
	550	-	-	-	-	-	-
	600	-	-	-	-	-	-
	650	-	-	-	-	-	-
	700	-	-	-	-	-	-
	750	-	-	-	-	-	-
	800	-	-	-	-	-	-
	850	-	-	-	-	-	-
900	-	-	-	-	-	-	
950	-	-	-	-	-	-	
1000	-	-	-	-	-	-	

**Cable track**

Wiring 1 (Next to Y-axis)	Y-axis stroke	50-300	350-600	650-900	950-1000
Wiring 2 (Next to Z-axis)	Z-axis stroke	50-200	250-300	-	-

**List by Cable Length**

Type	Cable code	Length
Standard type	1L	1m
	3L	3m
	5L	5m

\* Axis 1 comes with a standard cable, while axis 2 comes with a robot cable.  
\* Refer to P.90 for lengths other than those specified above.

**List of Options**

Name	Option code	
Opposite-home specification	NM	
Slider roller specification	SR	Axis 1 (Y-axis) Axis 2 (Z-axis)

**Specifications**

Item	Y axis	Z axis
Axis model	RCP2-SS8R	RCP2-SA7R
Stroke (Can be set in 50-mm increments)	50-1000mm	50-300mm
Max speed	High-speed type: 250mm/s	High-speed type: 360mm/s Medium-speed type: 180mm/s Low-speed type: 90mm/s
Motor size	56-square pulse motor	
Ball screw lead	High-speed type: 20mm	High-speed type: 16mm Medium-speed type: 8mm Low-speed type: 4mm
Drive method	Ball screw, ø16mm, rolled, C10	Ball screw, ø12mm, rolled, C10
Positioning repeatability	±0.02mm	
Base material	Dedicated alloy steel	Aluminum
Surrounding air temperature/humidity	0 to 40°C, 85% RH or below (non-condensing)	

Dimensions

You can download CAD drawings from our website. [www.intelligentactuator.com](http://www.intelligentactuator.com)



Note 1. The connected position shown in the drawing defines the home.  
 Note 2. Both wiring 1 and wiring 2 assume use of a cable track.  
 Note 3. For details on the cable track, refer to P.90.  
 Note 4. For details on the bracket on the moving end of the cable track, refer to P.90.

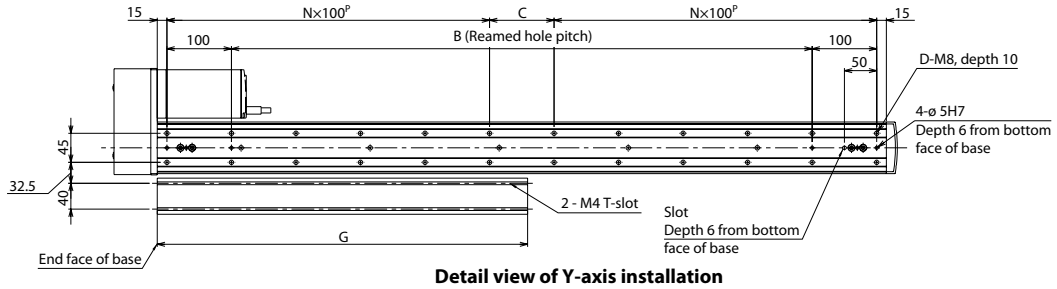

Detail view of Y-axis installation

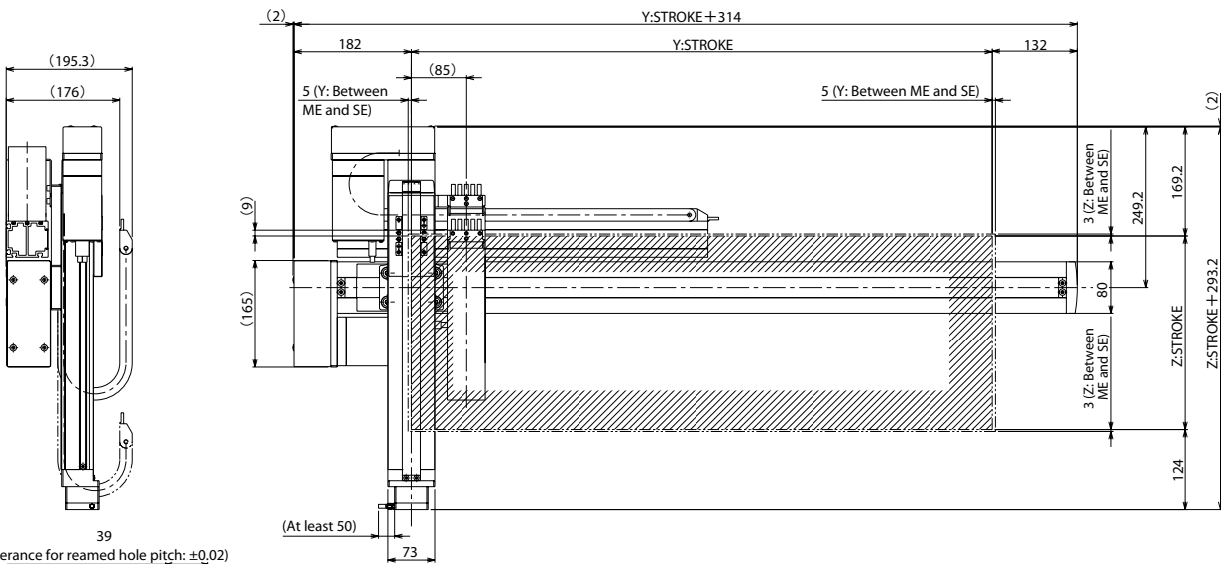
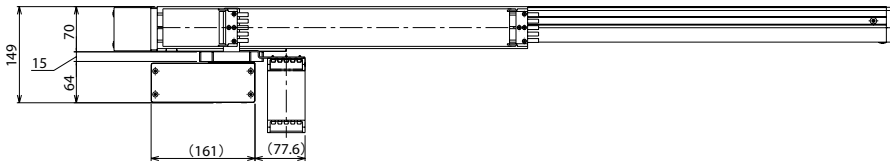

Detail view of Z-axis slider    Detail view of slot in bottom face of Y-axis base

Dimensions by Stroke

Y: Model	50	100	150	200	250	300	350	400	450	500	550	600	650	700	750	800	850	900	950	1000
B	50	100	150	200	250	300	350	400	450	500	550	600	650	700	750	800	850	900	950	1000
C	50	100	150	0	50	100	150	0	50	100	150	0	50	100	150	0	50	100	150	0
D	8	8	8	10	12	12	12	14	16	16	18	18	20	20	20	22	24	24	24	26
N	1	1	1	2	2	2	2	3	3	3	3	4	4	4	4	5	5	5	5	6
G	149	174	199	224	249	274	299	324	349	374	399	424	449	474	499	524	549	574	599	624

Controllers

Applicable controller

Refer to P. 91 for the controllers.

# IK2-SXBD1□□S

RCS2 2-axis Combinations X axis: SS7R (Reversed, Single-slider)  
Y axis: SA5R (Reversed)

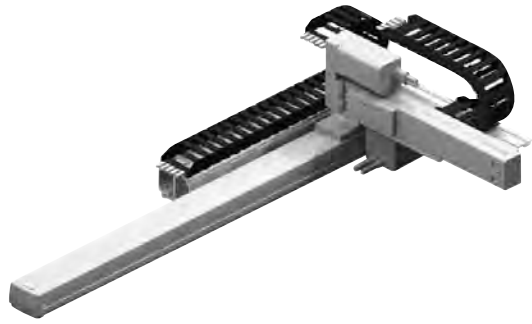
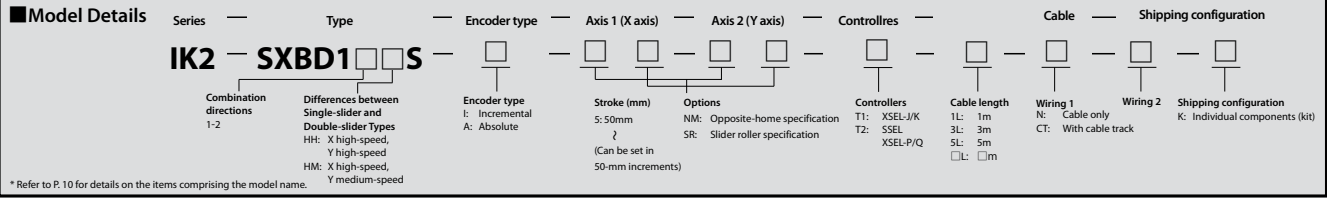

Both wiring 1 and wiring 2 assume use of a cable track.

**Maximum Stroke**

**X axis** 600 mm      **Y axis** 200 mm

**Maximum Speed**

	High-speed type	Medium-speed type
X axis	600mm/s	—
Y axis	800mm/s	400mm/s

**Maximum Load Capacity**

Y-axis stroke	X high-speed, Y high-speed	X high-speed, Y medium-speed
50mm	3.0kg	6.0kg
100mm	3.0kg	6.0kg
150mm	2.5kg	5.0kg
200mm	2.5kg	5.0kg

**List by Stroke**

Y-axis stroke		Incremental				Absolute			
		50	100	150	200	50	100	150	200
X-axis stroke	50	—	—	—	—	—	—	—	—
	100	—	—	—	—	—	—	—	—
	150	—	—	—	—	—	—	—	—
	200	—	—	—	—	—	—	—	—
	250	—	—	—	—	—	—	—	—
	300	—	—	—	—	—	—	—	—
	350	—	—	—	—	—	—	—	—
	400	—	—	—	—	—	—	—	—
	450	—	—	—	—	—	—	—	—
	500	—	—	—	—	—	—	—	—
	550	—	—	—	—	—	—	—	—
	600	—	—	—	—	—	—	—	—

**Cable track**

Wiring	X-axis stroke	50-300	350-600
Wiring 1 (Next to X-axis)	Y-axis stroke	—	—
Wiring 2 (Next to Y-axis)	X-axis stroke	50-200	—
	Y-axis stroke	—	—

**List by Cable Length**

Type	Cable code	Length
Standard type	1L	1m
	3L	3m
	5L	5m

\* Axis 1 comes with a standard cable, while axis 2 comes with a robot cable.

\* Refer to P. 90 for lengths other than those specified above.

**List of Options**

Name	Option code
Opposite-home specification	NM
Slider roller specification	SR

**Specifications**

Item	X axis	Y axis
Axis model	RCS2-SS7R	RCS2-SA5R
Stroke (Can be set in 50-mm increments)	50-600mm	50-200mm
Max speed	Stroke	50-200mm
	High speed	800mm/s
	Medium speed	400mm/s
Motor output (W)	60W	20W
Ball screw lead	High-speed type: 12mm	High-speed type: 12mm Medium-speed type: 6mm
Drive method	Ball screw, ø10 mm, rolled, C10	
Positioning repeatability	±0.02mm	
Base material	Dedicated alloy steel	Aluminum
Surrounding air temperature/humidity	0 to 40°C, 85% RH or below (non-condensing)	

Dimensions

You can download CAD drawings from our website. [www.intelligentactuator.com](http://www.intelligentactuator.com)

2D CAD

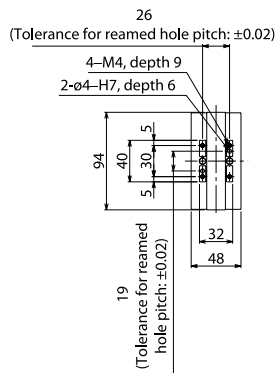
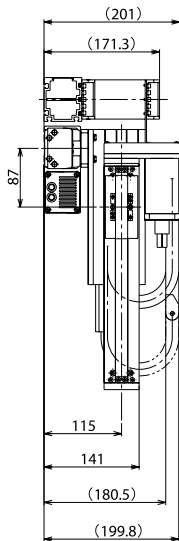

Detail view of Y-axis slider

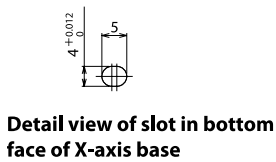

Detail view of slot in bottom face of X-axis base

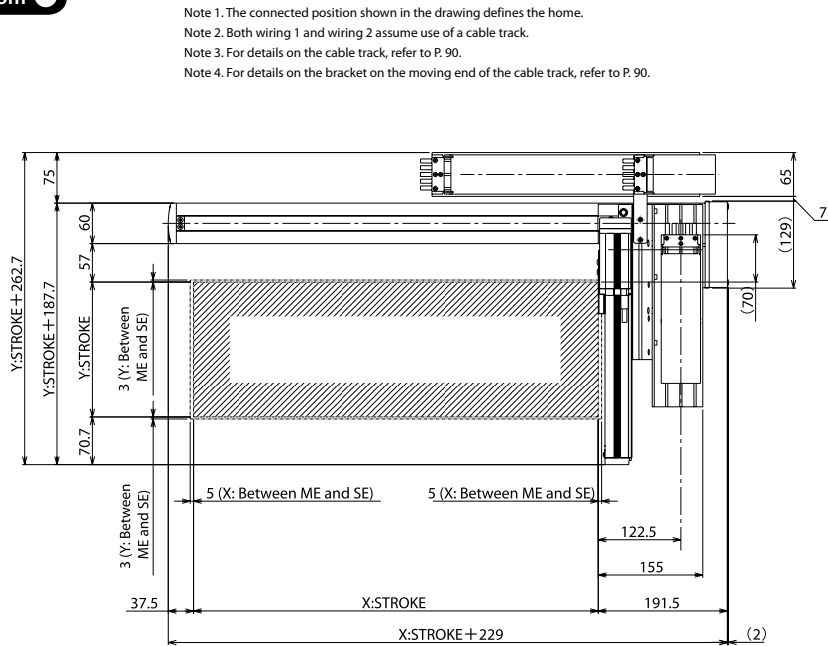

ME: Mechanical end  
SE: Stroke end

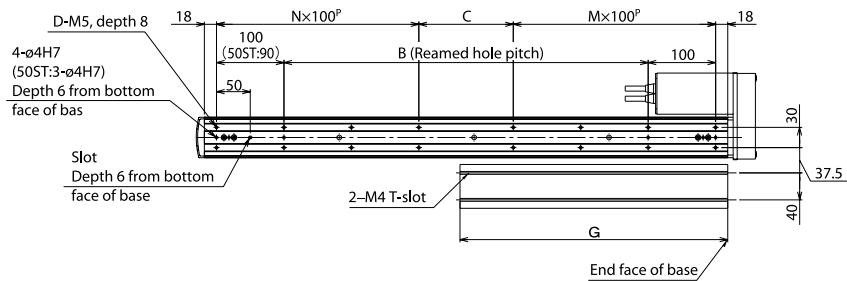
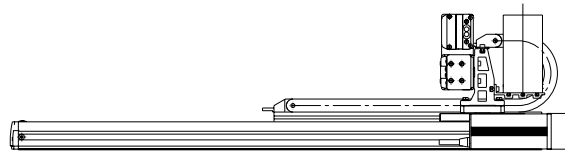

Detail view of X-axis installation

Dimensions by Stroke

X: Nominal stroke	50	100	150	200	250	300	350	400	450	500	550	600
B	0	40	90	140	190	240	290	340	390	440	490	540
C	90	40	90	140	190	40	90	140	190	40	90	140
D	6	8	8	8	8	12	12	12	12	16	16	16
M	1	1	1	1	1	2	2	2	2	3	3	3
N	0	1	1	1	1	2	2	2	2	3	3	3
G	122	147	172	197	222	247	272	297	322	347	372	397

Controllers

Applicable controller

Refer to P. 91 for the controllers.

# IK2-SXBD1□□D

RCS2 2-axis Combinations X axis: SS7R (Reversed, Double-slider)  
Y axis: SA5R (Reversed)

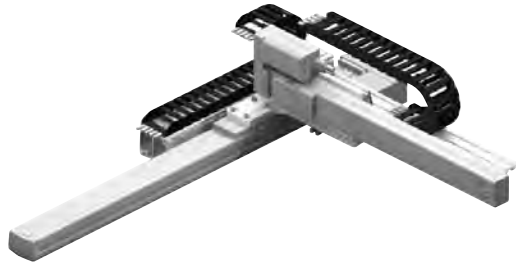
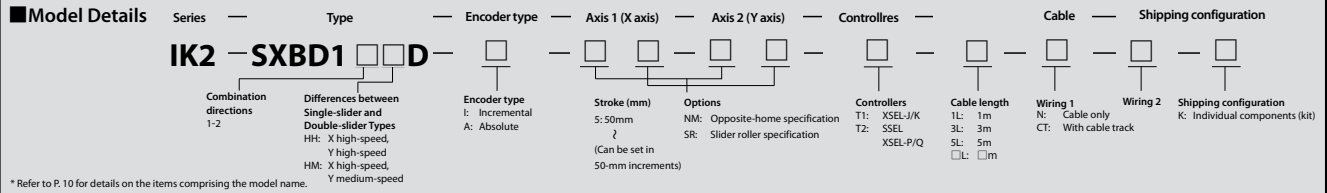

Both wiring 1 and wiring 2 assume use of a cable track.

### Maximum Stroke

**X axis** 450 mm

**Y axis** 400 mm

### Maximum Speed

	High-speed type	Medium-speed type
X axis	600mm/s	—
Y axis	800mm/s	400mm/s

### Maximum Load Capacity

Y-axis stroke	X high-speed, Y high-speed	X high-speed, Y medium-speed
250mm	2.5kg	5.0kg
300mm	2.0kg	4.0kg
350mm	2.0kg	4.0kg
400mm	2.0kg	4.0kg

### List by Stroke

Y-axis stroke	Incremental				Absolute			
	250	300	350	400	250	300	350	400
50	—	—	—	—	—	—	—	—
100	—	—	—	—	—	—	—	—
150	—	—	—	—	—	—	—	—
200	—	—	—	—	—	—	—	—
250	—	—	—	—	—	—	—	—
300	—	—	—	—	—	—	—	—
350	—	—	—	—	—	—	—	—
400	—	—	—	—	—	—	—	—
450	—	—	—	—	—	—	—	—

### Cable track

Wiring	Axis	Stroke	Length
Wiring 1 (Next to X-axis)	X-axis stroke	50-300	350-450
	Y-axis stroke	—	—
Wiring 2 (Next to Y-axis)	X-axis stroke	—	—
	Y-axis stroke	250-400	—

### List by Cable Length

Type	Cable code	Length
Standard type	1L	1m
	3L	3m
	5L	5m

\* Axis 1 comes with a standard cable, while axis 2 comes with a robot cable.

\* Refer to P. 90 for lengths other than those specified above.

### List of Options

Name	Option code
Opposite-home specification	<b>NM</b>
Slider roller specification	<b>SR</b>

### Specifications

Item	X axis	Y axis
Axis model	RCS2-SS7R	RCS2-SA5R
Stroke (Can be set in 50-mm increments)	50-450mm	250-400mm
Max speed	Stroke	250-400mm
	High speed	800mm/s
	Medium speed	400mm/s
Motor output (W)	60W	20W
Ball screw lead	High-speed type: 12mm	High-speed type: 12mm Medium-speed type: 6mm
Drive method	Ball screw, ø10 mm, rolled, C10	
Positioning repeatability	±0.02mm	
Base material	Dedicated alloy steel	Aluminum
Surrounding air temperature/humidity	0 to 40°C, 85% RH or below (non-condensing)	



Dimensions

You can download CAD drawings from our website. [www.intelligentactuator.com](http://www.intelligentactuator.com)

Note 1. The connected position shown in the drawing defines the home.  
 Note 2. Both wiring 1 and wiring 2 assume use of a cable track.  
 Note 3. For details on the cable track, refer to P. 90.  
 Note 4. For details on the bracket on the moving end of the cable track, refer to P. 90.

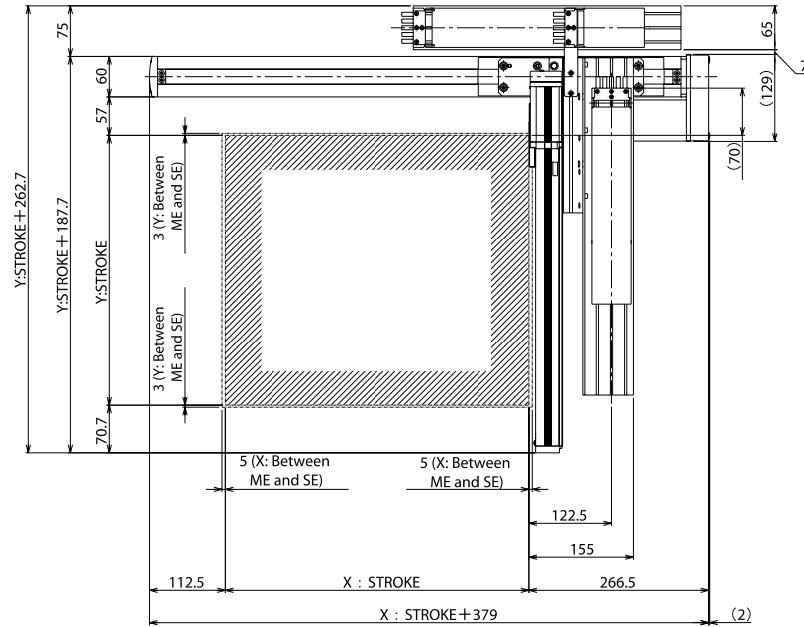
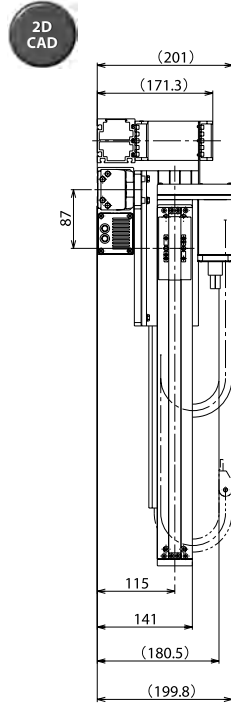

26  
 (Tolerance for reamed hole pitch: ±0.02)

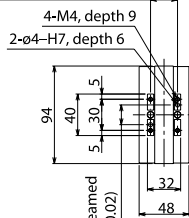

ME: Mechanical end  
 SE: Stroke end

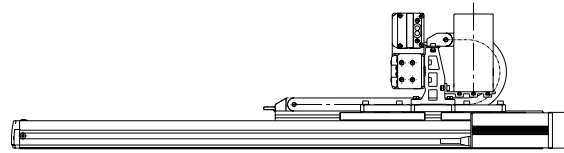

Detail view of Y-axis slider



Detail view of slot in bottom face of X-axis base

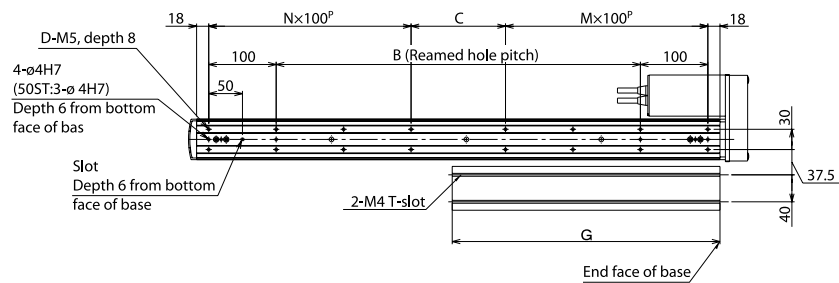

Detail view of X-axis installation

■ Dimensions by Stroke

X: Nominal stroke	200	250	300	350	400	450	500	550	600
X: Effective stroke	50	100	150	200	250	300	350	400	450
B	140	190	240	290	340	390	440	490	540
C	140	190	40	90	140	190	40	90	140
D	8	8	12	12	12	12	16	16	16
M	1	1	2	2	2	2	3	3	3
N	1	1	2	2	2	2	3	3	3
G	197	222	247	272	297	322	347	372	397

Controllers

Applicable controller

Refer to P. 91 for the controllers.

# IK2-SXBD2□□S

RCS2 2-axis Combinations X axis: S57C (Reversed, Single-slider)  
Y axis: SA5R (Reversed)

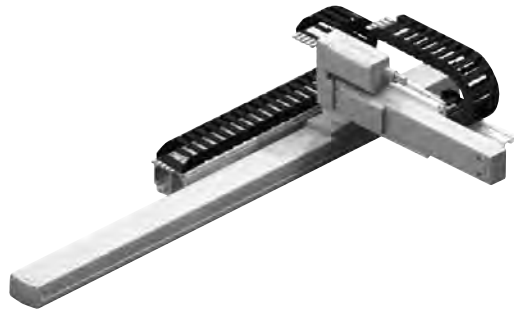
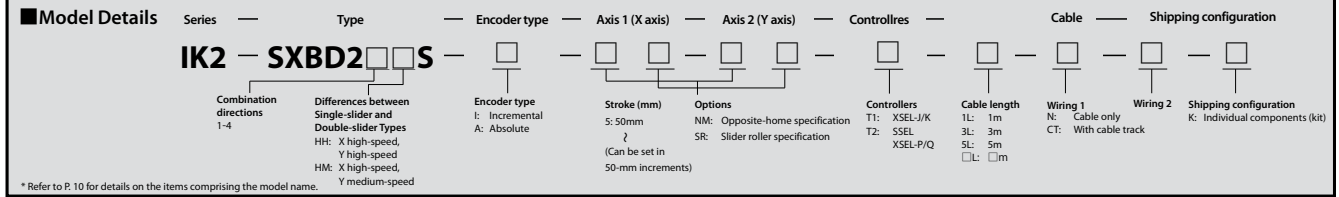

Both wiring 1 and wiring 2 assume use of a cable track.

**Maximum Stroke**

X axis 600 mm Y axis 200 mm

**Maximum Speed**

	High-speed type	Medium-speed type
X axis	600mm/s	—
Y axis	800mm/s	400mm/s

**Maximum Load Capacity**

Y-axis stroke	X high-speed, Y high-speed	X high-speed, Y medium-speed
50mm	3.0kg	6.0kg
100mm	3.0kg	6.0kg
150mm	2.5kg	5.0kg
200mm	2.5kg	5.0kg

**List by Stroke**

		Incremental				Absolute			
		Y-axis stroke	50	100	150	200	50	100	150
X-axis stroke	50	—	—	—	—	—	—	—	—
	100	—	—	—	—	—	—	—	—
	150	—	—	—	—	—	—	—	—
	200	—	—	—	—	—	—	—	—
	250	—	—	—	—	—	—	—	—
	300	—	—	—	—	—	—	—	—
	350	—	—	—	—	—	—	—	—
	400	—	—	—	—	—	—	—	—
	450	—	—	—	—	—	—	—	—
	500	—	—	—	—	—	—	—	—
	550	—	—	—	—	—	—	—	—
600	—	—	—	—	—	—	—	—	

**Cable track**

Wiring	X-axis stroke	50-300	350-600
Wiring 1 (Next to X-axis)	Y-axis stroke	—	—
Wiring 2 (Next to Y-axis)	Y-axis stroke	50-200	—

**List by Cable Length**

Type	Cable code	Length
Standard type	1L	1m
	3L	3m
	5L	5m

\* Axis 1 comes with a standard cable, while axis 2 comes with a robot cable.

\* Refer to P.90 for lengths other than those specified above.

**List of Options**

Name	Option code	
Opposite-home specification	NM	
Slider roller specification	SR	Axis 1 (X-axis) Axis 2 (Y-axis)

**Specifications**

Item	X axis	Y axis
Axis model	RCS2-S57C	RCS2-SA5R
Stroke (Can be set in 50-mm increments)	50-600mm	50-200mm
Max speed	Stroke	50-500mm 600mm/s
	High speed	550-600mm 470mm/s
	Medium speed	—
Motor output (W)	60W	20W
Ball screw lead	High-speed type: 12mm	High-speed type: 12mm Medium-speed type: 6mm
Drive method	Ball screw, ø10 mm, rolled, C10	
Positioning repeatability	±0.02mm	
Base material	Dedicated alloy steel	Aluminum
Surrounding air temperature/humidity	0 to 40°C, 85% RH or below (non-condensing)	

Dimensions

You can download CAD drawings from our website. [www.intelligentactuator.com](http://www.intelligentactuator.com)

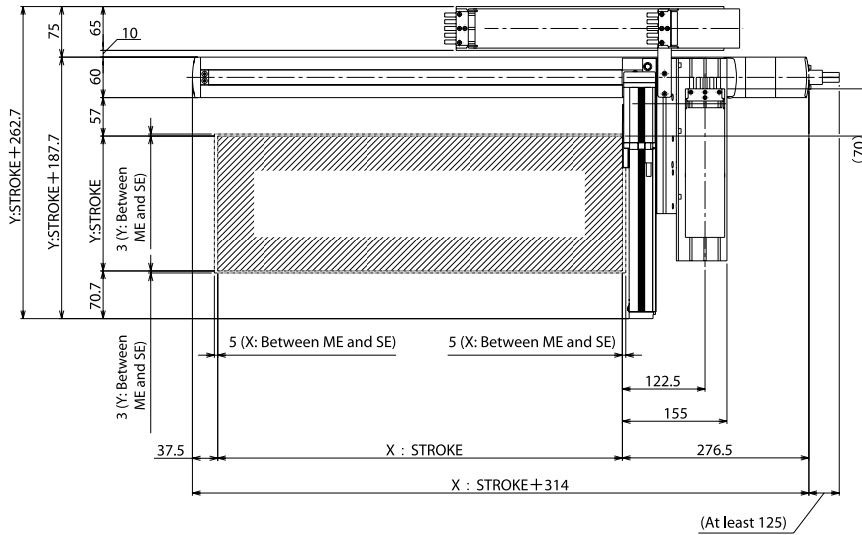
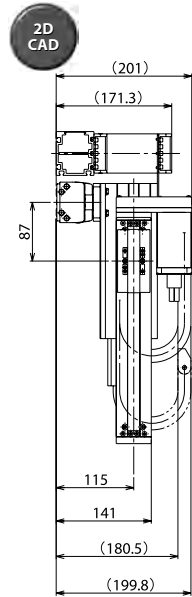

ME: Mechanical end  
 SE: Stroke end

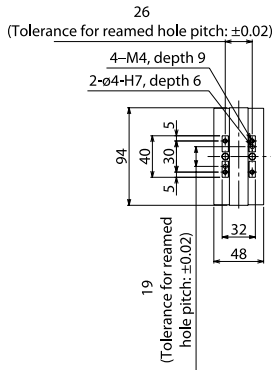
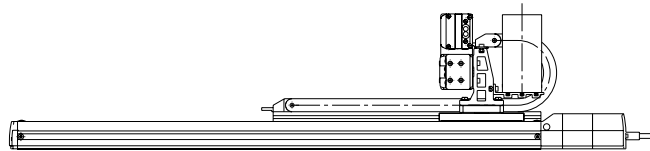

Detail view of Y-axis slider



Detail view of slot in bottom face of X-axis base

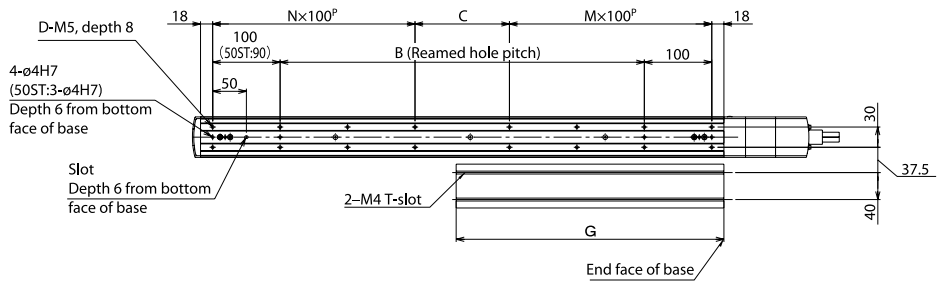

Detail view of X-axis installation

■ Dimensions by Stroke

X: Nominal stroke	50	100	150	200	250	300	350	400	450	500	550	600
B	0	40	90	140	190	240	290	340	390	440	490	540
C	90	40	90	140	190	40	90	140	190	40	90	140
D	6	8	8	8	8	12	12	12	12	16	16	16
M	1	1	1	1	1	2	2	2	2	3	3	3
N	0	1	1	1	1	2	2	2	2	3	3	3
G	122	147	172	197	222	247	272	297	322	347	372	397

Controllers

Applicable controller

Refer to P. 91 for the controllers.

# IK2-SXBD2□□D

RCS2 2-axis Combinations X axis: SS7C (Straight, Double-slider) Y axis: SA5R (Reversed)

**Model Details**

Series: IK2 — Type: SXBD2□□D — Encoder type: [ ] — Axis 1 (X axis): [ ] — Axis 2 (Y axis): [ ] — Controllers: [ ] — Cable: [ ] — Shipping configuration: [ ]

Combination directions 1-4: [ ] — Differences between Single-slider and Double-slider Types: HH: X high-speed, Y high-speed; HM: X high-speed, Y medium-speed — Encoder type: I: Incremental; A: Absolute — Stroke (mm): 5: 50mm; ? (Can be set in 50-mm increments) — Options: NM: Opposite-home specification; SR: Slider roller specification — Controllers: T1: XSEL-J/K; T2: SSEL; XSEL-P/Q — Cable length: 1L: 1m; 3L: 3m; 5L: 5m; □L: □m — Wiring 1: N: Cable only; CT: With cable track — Wiring 2: [ ] — Shipping configuration: K: Individual components (kit)

\* Refer to P.10 for details on the items comprising the model name.

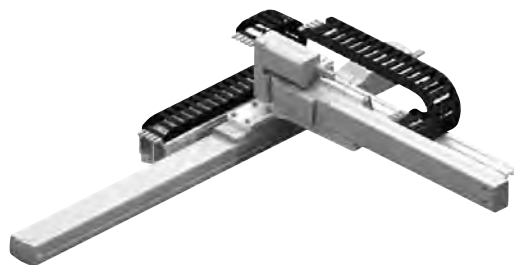

Both wiring 1 and wiring 2 assume use of a cable track.

**Maximum Stroke**

X axis 450 mm Y axis 400 mm

**Maximum Speed**

	High-speed type	Medium-speed type
X axis	600mm/s	-
Y axis	800mm/s	400mm/s

**Maximum Load Capacity**

Y-axis stroke	X high-speed, Y high-speed	X high-speed, Y medium-speed
250mm	2.5kg	5.0kg
300mm	2.0kg	4.0kg
350mm	2.0kg	4.0kg
400mm	2.0kg	4.0kg

**List by Stroke**

Y-axis stroke	Incremental				Absolute			
	250	300	350	400	250	300	350	400
50	-	-	-	-	-	-	-	-
100	-	-	-	-	-	-	-	-
150	-	-	-	-	-	-	-	-
200	-	-	-	-	-	-	-	-
250	-	-	-	-	-	-	-	-
300	-	-	-	-	-	-	-	-
350	-	-	-	-	-	-	-	-
400	-	-	-	-	-	-	-	-
450	-	-	-	-	-	-	-	-

**Cable track**

	X-axis stroke	50-300	350-450
Wiring 1 (Next to X-axis)	X-axis stroke	-	-
Wiring 2 (Next to Y-axis)	Y-axis stroke	250-400	-

**List by Cable Length**

Type	Cable code	Length
Standard type	1L	1m
	3L	3m
	5L	5m

\* Axis 1 comes with a standard cable, while axis 2 comes with a robot cable.

\* Refer to P. 90 for lengths other than those specified above.

**List of Options**

Name	Option code	
Opposite-home specification	NM	
Slider roller specification	SR	Axis 1 (X-axis) Axis 2 (Y-axis)

**Specifications**

Item	X axis	Y axis
Axis model	RCS2-SS7C	RCS2-SA5R
Stroke (Can be set in 50-mm increments)	50-450mm	250-400mm
Max speed	Stroke	250-400mm
	High speed	800mm/s
	Medium speed	400mm/s
Motor output (W)	60W	20W
Ball screw lead	High-speed type: 12mm	High-speed type: 12mm Medium-speed type: 6mm
Drive method	Ball screw, ø10 mm, rolled, C10	
Positioning repeatability	±0.02mm	
Base material	Dedicated alloy steel	Aluminum
Surrounding air temperature/humidity	0 to 40°C, 85% RH or below (non-condensing)	

Dimensions

You can download CAD drawings from our website. [www.intelligentactuator.com](http://www.intelligentactuator.com)

Note 1. The connected position shown in the drawing defines the home.  
 Note 2. Both wiring 1 and wiring 2 assume use of a cable track.  
 Note 3. For details on the cable track, refer to P. 90.  
 Note 4. For details on the bracket on the moving end of the cable track, refer to P. 90.

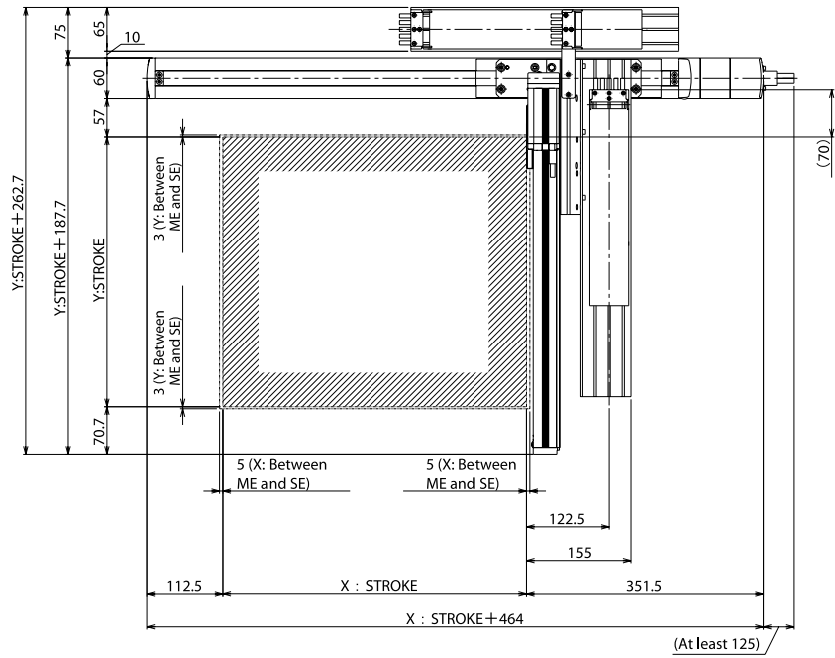
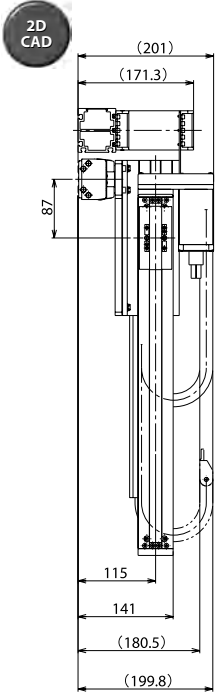

26  
 (Tolerance for reamed hole pitch: ±0.02)

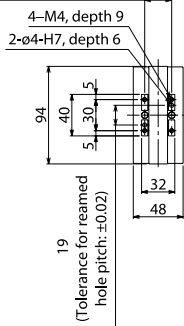

Detail view of Y-axis slider



Detail view of slot in bottom face of X-axis base

ME: Mechanical end  
 SE: Stroke end

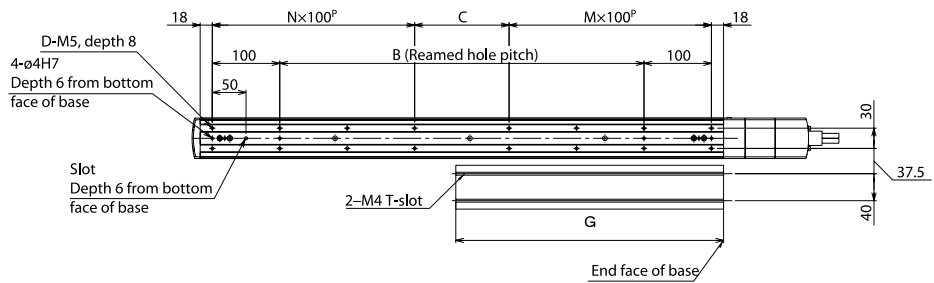
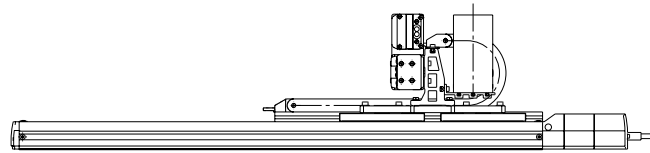

Detail view of X-axis installation

■ Dimensions by Stroke

X: Nominal stroke	200	250	300	350	400	450	500	550	600
X: Effective stroke	50	100	150	200	250	300	350	400	450
B	140	190	240	290	340	390	440	490	540
C	140	190	40	90	140	190	40	90	140
D	8	8	12	12	12	12	16	16	16
M	1	1	2	2	2	2	3	3	3
N	1	1	2	2	2	2	3	3	3
G	197	222	247	272	297	322	347	372	397

Controllers

Applicable controller

Refer to P. 91 for the controllers.

# IK2-SXBC1□□S

RCS2 2-axis Combinations X axis: SS7R (Reversed, Single-slider)  
Y axis: SA6R (Reversed)

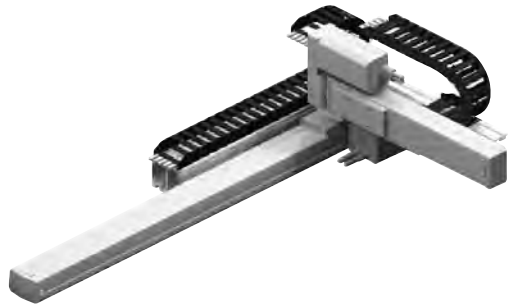
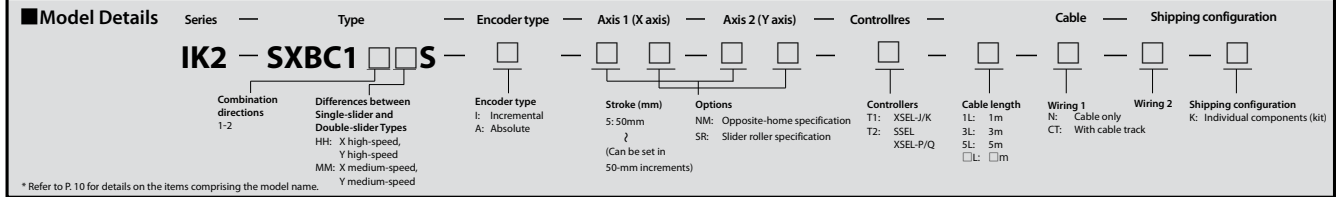

Both wiring 1 and wiring 2 assume use of a cable track.

**Maximum Stroke**

X axis 600 mm      Y axis 200 mm

**Maximum Speed**

	High-speed type	Medium-speed type
X axis	600mm/s	300mm/s
Y axis	800mm/s	400mm/s

**Maximum Load Capacity**

Y-axis stroke	X high-speed, Y high-speed	X medium-speed, Y medium-speed
50mm	4.5kg	9.0kg
100mm	4.5kg	9.0kg
150mm	4.0kg	8.0kg
200mm	3.0kg	6.0kg

**List by Stroke**

Y-axis stroke	Incremental				Absolute			
	50	100	150	200	50	100	150	200
50	-	-	-	-	-	-	-	-
100	-	-	-	-	-	-	-	-
150	-	-	-	-	-	-	-	-
200	-	-	-	-	-	-	-	-
250	-	-	-	-	-	-	-	-
300	-	-	-	-	-	-	-	-
350	-	-	-	-	-	-	-	-
400	-	-	-	-	-	-	-	-
450	-	-	-	-	-	-	-	-
500	-	-	-	-	-	-	-	-
550	-	-	-	-	-	-	-	-
600	-	-	-	-	-	-	-	-

**Cable track**

Wiring 1 (Next to X-axis)	X-axis stroke	50-300	350-600
Wiring 2 (Next to Y-axis)	Y-axis stroke	50-200	-

**List by Cable Length**

Type	Cable code	Length
Standard type	1L	1m
	3L	3m
	5L	5m

\* Axis 1 comes with a standard cable, while axis 2 comes with a robot cable.

\* Refer to P. 90 for lengths other than those specified above.

**List of Options**

Name	Option code	
Opposite-home specification	NM	
Slider roller specification	SR	Axis 1 (X-axis) Axis 2 (Y-axis)

**Specifications**

Item	X axis	Y axis
Axis model	RCS2-SS7R	RCS2-SA6R
Stroke (Can be set in 50-mm increments)	50-600mm	50-200mm
Max speed	Stroke	50-500mm
	High speed	600mm/s
	Medium speed	300mm/s
Motor output (W)	60W	30W
Ball screw lead	High-speed type: 12mm Medium-speed type: 6mm	
Drive method	Ball screw, ø10 mm, rolled, C10	
Positioning repeatability	±0.02mm	
Base material	Dedicated alloy steel	Aluminum
Surrounding air temperature/humidity	0 to 40°C, 85% RH or below (non-condensing)	

Dimensions

You can download CAD drawings from our website.

www.intelligentactuator.com

2D CAD

Note 1. The connected position shown in the drawing defines the home.  
 Note 2. Both wiring 1 and wiring 2 assume use of a cable track.  
 Note 3. For details on the cable track, refer to P. 90.  
 Note 4. For details on the bracket on the moving end of the cable track, refer to P. 90.

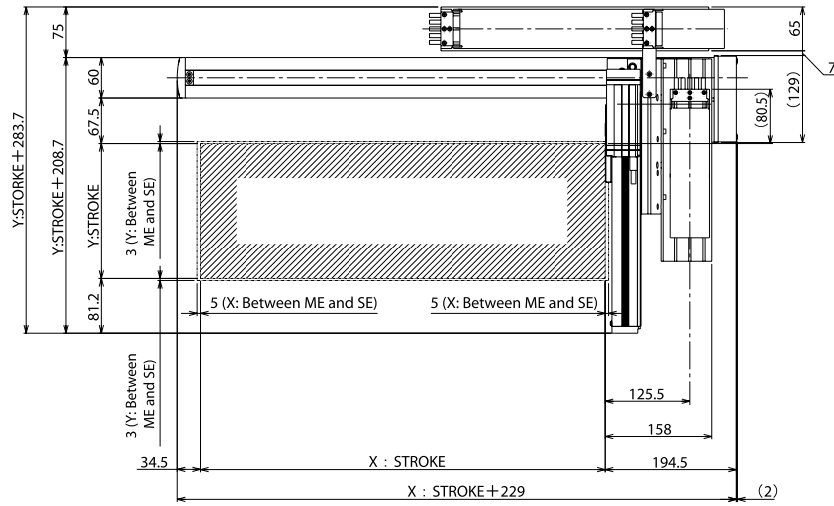
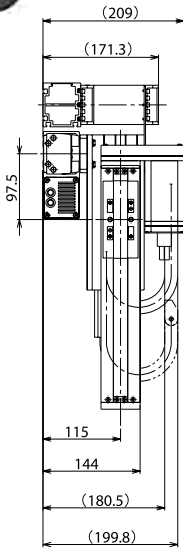

31  
(Tolerance for reamed hole pitch: ±0.02)

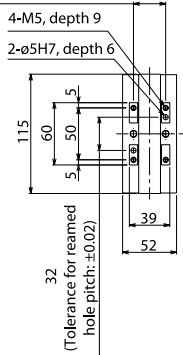

ME: Mechanical end  
 SE: Stroke end

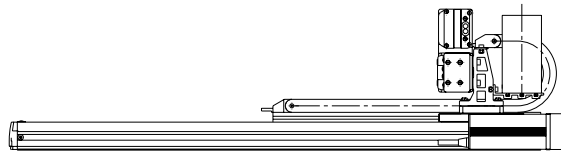

Detail view of Y-axis slider



Detail view of slot in bottom face of X-axis base

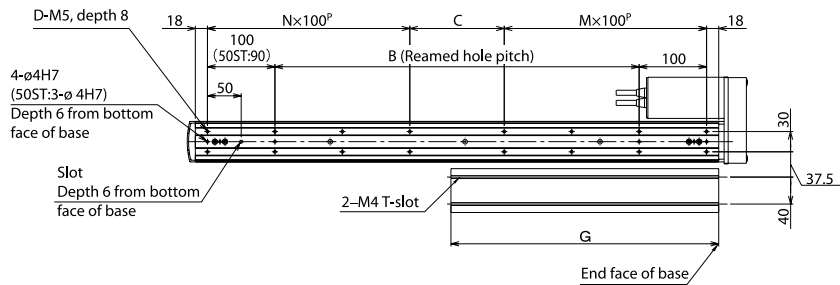

Detail view of X-axis installation

Dimensions by Stroke

X: Nominal stroke	50	100	150	200	250	300	350	400	450	500	550	600
B	0	40	90	140	190	240	290	340	390	440	490	540
C	90	40	90	140	190	40	90	140	190	40	90	140
D	6	8	8	8	8	12	12	12	12	16	16	16
M	1	1	1	1	1	2	2	2	2	3	3	3
N	0	1	1	1	1	2	2	2	2	3	3	3
G	122	147	172	197	222	247	272	297	322	347	372	397

Controllers

Applicable controller



Refer to P. 91 for the controllers.



# IK2-SXBC1□□D

RCS2 2-axis Combinations X axis: SS7R (Reversed, Double-slider)  
Y axis: SA6R (Reversed)

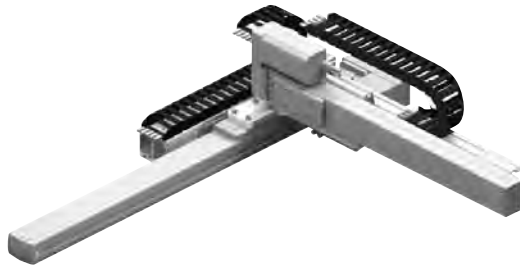
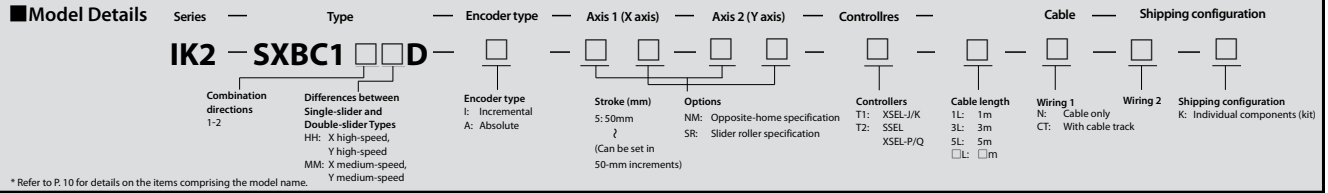

Both wiring 1 and wiring 2 assume use of a cable track.

**Maximum Stroke**

X axis 450 mm

Y axis 400 mm

**Maximum Speed**

	High-speed type	Medium-speed type
X axis	600mm/s	300mm/s
Y axis	800mm/s	400mm/s

**Maximum Load Capacity**

Y-axis stroke	X high-speed, Y high-speed	X medium-speed, Y medium-speed
250mm	3.0kg	6.0kg
300mm	3.0kg	6.0kg
350mm	3.0kg	6.0kg
400mm	3.0kg	6.0kg

**List by Stroke**

Y-axis stroke	Incremental				Absolute			
	250	300	350	400	250	300	350	400
50	-	-	-	-	-	-	-	-
100	-	-	-	-	-	-	-	-
150	-	-	-	-	-	-	-	-
200	-	-	-	-	-	-	-	-
250	-	-	-	-	-	-	-	-
300	-	-	-	-	-	-	-	-
350	-	-	-	-	-	-	-	-
400	-	-	-	-	-	-	-	-
450	-	-	-	-	-	-	-	-

**Cable track**

	X-axis stroke	50-300	350-450
Wiring 1 (Next to X-axis)			
Wiring 2 (Next to Y-axis)	Y-axis stroke	250-400	-

**List by Cable Length**

Type	Cable code	Length
Standard type	1L	1m
	3L	3m
	5L	5m

\* Axis 1 comes with a standard cable, while axis 2 comes with a robot cable.

\* Refer to P. 90 for lengths other than those specified above.

**List of Options**

Name	Option code	
Opposite-home specification	NM	
Slider roller specification	SR	Axis 1 (X-axis) Axis 2 (Y-axis)

**Specifications**

Item	X axis	Y axis	
Axis model	RCS2-SS7R	RCS2-SA6R	
Stroke (Can be set in 50-mm increments)	50-450mm	250-400mm	
Max speed	Stroke	250-400mm	
	High speed	600mm/s	800mm/s
	Medium speed	300mm/s	400mm/s
Motor output (W)	60W	30W	
Ball screw lead	High-speed type: 12mm Medium-speed type: 6mm		
Drive method	Ball screw, ø10 mm, rolled, C10		
Positioning repeatability	±0.02mm		
Base material	Dedicated alloy steel	Aluminum	
Surrounding air temperature/humidity	0 to 40°C, 85% RH or below (non-condensing)		

Dimensions

You can download CAD drawings from our website. [www.intelligentactuator.com](http://www.intelligentactuator.com)

2D CAD

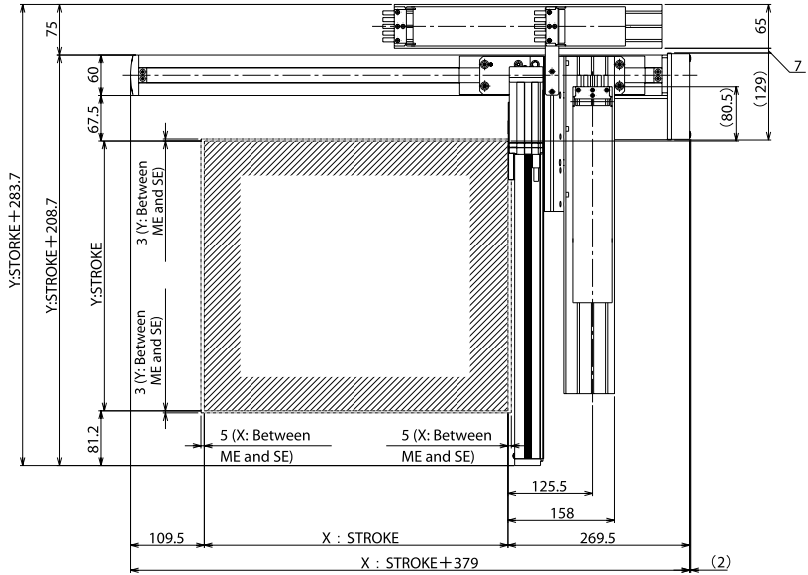
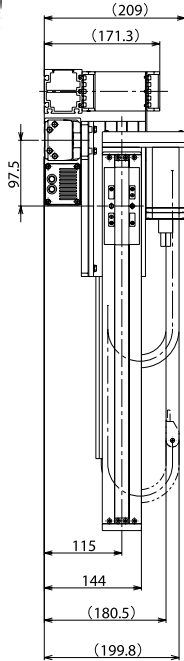

Note 1. The connected position shown in the drawing defines the home.

Note 2. Both wiring 1 and wiring 2 assume use of a cable track.

Note 3. For details on the cable track, refer to P. 90.

Note 4. For details on the bracket on the moving end of the cable track, refer to P. 90.

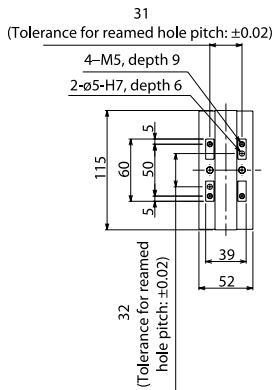

Detail view of Y-axis slider



Detail view of slot in bottom face of X-axis base

ME: Mechanical end  
SE: Stroke end

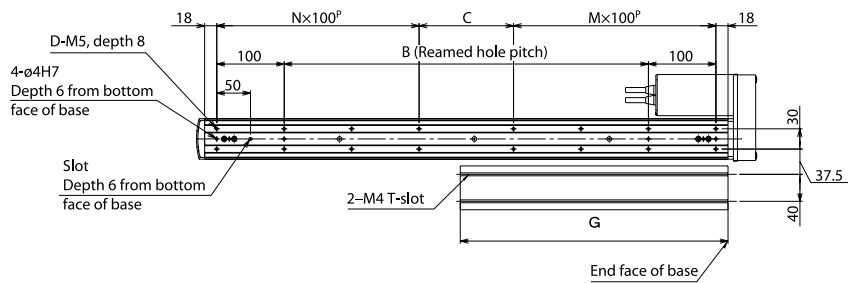
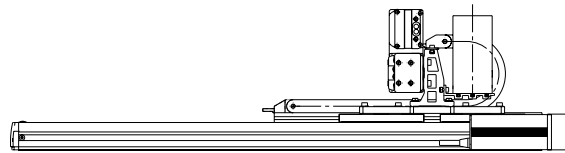

Detail view of X-axis installation

■ Dimensions by Stroke

X: Nominal stroke	200	250	300	350	400	450	500	550	600
X: Effective stroke	50	100	150	200	250	300	350	400	450
B	140	190	240	290	340	390	440	490	540
C	140	190	40	90	140	190	40	90	140
D	8	8	12	12	12	12	16	16	16
M	1	1	2	2	2	2	3	3	3
N	1	1	2	2	2	2	3	3	3
G	197	222	247	272	297	322	347	372	397

Controllers

Applicable controller



Refer to P. 91 for the controllers.

# IK2-SXBC2□□S

RCS2 2-axis Combinations X axis: SS7C (Straight, Single-slider)  
Y axis: SA6R (Reversed)

**Model Details**

Series: **IK2** Type: **SXBC2** Encoder type: **S**

Axis 1 (X axis): **□** Axis 2 (Y axis): **□** Controllres: **□** Cable: **□** Shipping configuration: **□**

**Combination directions 1-4**

**Differences between Single-slider and Double-slider Types**  
 HH: X high-speed, Y high-speed  
 MM: X medium-speed, Y medium-speed

**Encoder type**  
 I: Incremental  
 A: Absolute

**Stroke (mm)**  
 5: 50mm  
 ? (Can be set in 50-mm increments)

**Options**  
 NM: Opposite-home specification  
 SR: Slider roller specification

**Controllers**  
 T1: XSEL-J/K  
 T2: SSEL  
 XSEL-P/Q

**Cable length**  
 1L: 1m  
 3L: 3m  
 5L: 5m  
 □L: □m

**Wiring 1**  
 N: Cable only  
 CT: With cable track

**Wiring 2**  
 K: Individual components (kit)

\* Refer to P.10 for details on the items comprising the model name.

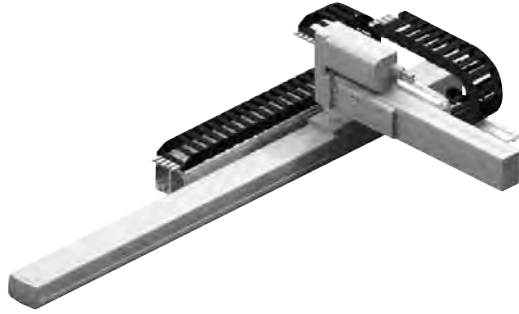

Both wiring 1 and wiring 2 assume use of a cable track.

**Maximum Stroke**

X axis **600 mm** Y axis **200 mm**

**Maximum Speed**

	High-speed type	Medium-speed type
X axis	600mm/s	300mm/s
Y axis	800mm/s	400mm/s

**Maximum Load Capacity**

Y-axis stroke	X high-speed, Y high-speed	X medium-speed, Y medium-speed
50mm	4.5kg	9.0kg
100mm	4.5kg	9.0kg
150mm	4.0kg	8.0kg
200mm	3.0kg	6.0kg

**List by Stroke**

Y-axis stroke		Incremental				Absolute			
		50	100	150	200	50	100	150	200
X-axis stroke	50	-	-	-	-	-	-	-	-
	100	-	-	-	-	-	-	-	-
	150	-	-	-	-	-	-	-	-
	200	-	-	-	-	-	-	-	-
	250	-	-	-	-	-	-	-	-
	300	-	-	-	-	-	-	-	-
	350	-	-	-	-	-	-	-	-
	400	-	-	-	-	-	-	-	-
	450	-	-	-	-	-	-	-	-
	500	-	-	-	-	-	-	-	-
	550	-	-	-	-	-	-	-	-
600	-	-	-	-	-	-	-	-	

**Cable track**

Wiring	X-axis stroke	50-300	350-600
Wiring 1 (Next to X-axis)	Y-axis stroke	50-200	-
Wiring 2 (Next to Y-axis)	X-axis stroke	-	50-300
	Y-axis stroke	-	350-600

**List by Cable Length**

Type	Cable code	Length
Standard type	1L	1m
	3L	3m
	5L	5m

\* Axis 1 comes with a standard cable, while axis 2 comes with a robot cable.  
 \* Refer to P.90 for lengths other than those specified above.

**List of Options**

Name	Option code	
Opposite-home specification	NM	
Slider roller specification	SR	Axis 1 (X-axis) Axis 2 (Y-axis)

**Specifications**

Item	X axis	Y axis
Axis model	RCS2-SS7C	RCS2-SA6R
Stroke (Can be set in 50-mm increments)	50-600mm	50-200mm
Max speed	Stroke	50-500mm
	High speed	600mm/s
	Medium speed	300mm/s
Motor output (W)	60W	30W
Ball screw lead	High-speed type: 12mm Medium-speed type: 6mm	
Drive method	Ball screw, ø10 mm, rolled, C10	
Positioning repeatability	±0.02mm	
Base material	Dedicated alloy steel	Aluminum
Surrounding air temperature/humidity	0 to 40°C, 85% RH or below (non-condensing)	

Dimensions

You can download CAD drawings from our website.

[www.intelligentactuator.com](http://www.intelligentactuator.com)

Note 1. The connected position shown in the drawing defines the home.

Note 2. Both wiring 1 and wiring 2 assume use of a cable track.

Note 3. For details on the cable track, refer to P. 90.

Note 4. For details on the bracket on the moving end of the cable track, refer to P. 90.

2D CAD

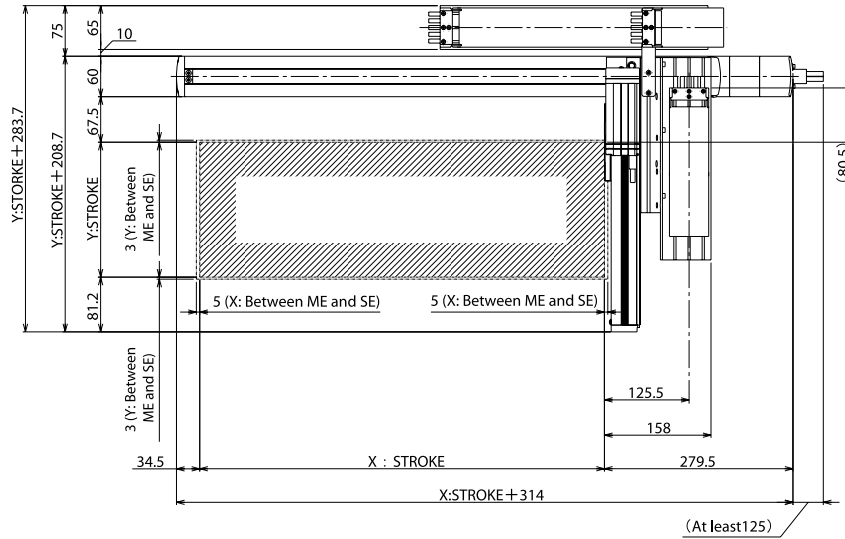
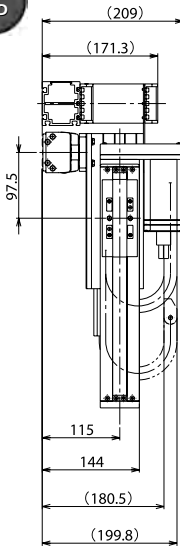

31  
(Tolerance for reamed hole pitch: ±0.02)

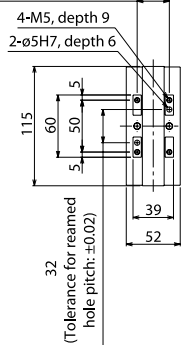

ME: Mechanical end  
SE: Stroke end

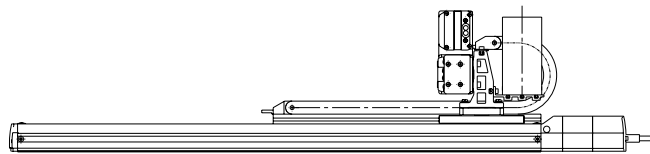

Detail view of Y-axis slider



Detail view of slot in bottom face of X-axis base

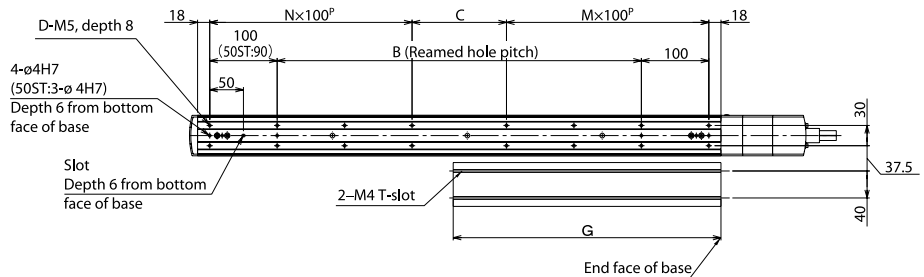

Detail view of X-axis installation

Dimensions by Stroke

X: Nominal stroke	50	100	150	200	250	300	350	400	450	500	550	600
B	0	40	90	140	190	240	290	340	390	440	490	540
C	90	40	90	140	190	40	90	140	190	40	90	140
D	6	8	8	8	8	12	12	12	12	16	16	16
M	1	1	1	1	1	2	2	2	2	3	3	3
N	0	1	1	1	1	2	2	2	2	3	3	3
G	122	147	172	197	222	247	272	297	322	347	372	397

Controllers

Applicable controller



Refer to P. 91 for the controllers.

# IK2-SXBC2□□D

RCS2 2-axis Combinations X axis: SS7C (Straight, Double-slider)  
Y axis: SA6R (Reversed)

**Model Details**

Series: **IK2** Type: **SXBC2** Encoder type:  Axis 1 (X axis):  Axis 2 (Y axis):  Controllers:  Cable:  Shipping configuration:

**IK2-SXBC2**   **D**

Combination directions 1-4:  Differences between Single-slider and Double-slider Types: HH: X high-speed, Y high-speed; MM: X medium-speed, Y medium-speed

Encoder type: I: Incremental; A: Absolute

Stroke (mm): S: 50mm; ? (Can be set in 50-mm increments)

Options: NM: Opposite-home specification; SR: Slider roller specification

Controllers: T1: XSEL-J/K; SSEL; T2: XSEL-P/Q

Cable length: 1L: 1m; 3L: 3m; 5L: 5m;

Wiring 1: N: Cable only; CT: With cable track

Wiring 2:

Shipping configuration: K: Individual components (kit)

\* Refer to P.10 for details on the items comprising the model name.

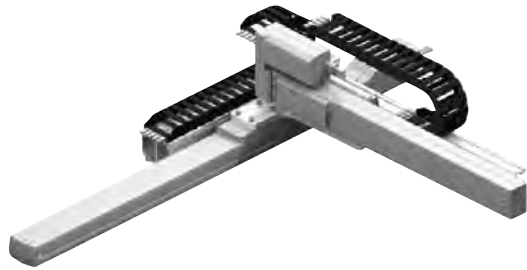

Both wiring 1 and wiring 2 assume use of a cable track.

**Maximum Stroke**

X axis **450 mm** Y axis **400 mm**

**Maximum Speed**

	High-speed type	Medium-speed type
X axis	600mm/s	300mm/s
Y axis	800mm/s	400mm/s

**Maximum Load Capacity**

Y-axis stroke	X high-speed, Y high-speed	X medium-speed, Y medium-speed
250mm	3.0kg	6.0kg
300mm	3.0kg	6.0kg
350mm	3.0kg	6.0kg
400mm	3.0kg	6.0kg

**List by Stroke**

Y-axis stroke	Incremental				Absolute			
	250	300	350	400	250	300	350	400
50	-	-	-	-	-	-	-	-
100	-	-	-	-	-	-	-	-
150	-	-	-	-	-	-	-	-
200	-	-	-	-	-	-	-	-
250	-	-	-	-	-	-	-	-
300	-	-	-	-	-	-	-	-
350	-	-	-	-	-	-	-	-
400	-	-	-	-	-	-	-	-
450	-	-	-	-	-	-	-	-

**Cable track**

Wiring 1 (Next to X-axis)	X-axis stroke	50-300	350-450
			-
Wiring 2 (Next to Y-axis)	Y-axis stroke	250-400	-
			-

**List by Cable Length**

Type	Cable code	Length
Standard type	1L	1m
	3L	3m
	5L	5m

\* Axis 1 comes with a standard cable, while axis 2 comes with a robot cable.

\* Refer to P.90 for lengths other than those specified above.

**List of Options**

Name	Option code	
Opposite-home specification	<b>NM</b>	
Slider roller specification	<b>SR</b>	Axis 1 (X-axis) Axis 2 (Y-axis)

**Specifications**

Item	X axis	Y axis	
Axis model	RCS2-SS7C	RCS2-SA6R	
Stroke (Can be set in 50-mm increments)	50-450mm	250-400mm	
Max speed	Stroke	250-400mm	
	High speed	600mm/s	800mm/s
	Medium speed	300mm/s	400mm/s
Motor output (W)	60W	30W	
Ball screw lead	High-speed type: 12mm Medium-speed type: 6mm		
Drive method	Ball screw, ø10 mm, rolled, C10		
Positioning repeatability	±0.02mm		
Base material	Dedicated alloy steel	Aluminum	
Surrounding air temperature/humidity	0 to 40°C, 85% RH or below (non-condensing)		

Dimensions

You can download CAD drawings from our website.

www.intelligentactuator.com

Note 1. The connected position shown in the drawing defines the home.  
 Note 2. Both wiring 1 and wiring 2 assume use of a cable track.  
 Note 3. For details on the cable track, refer to P. 90.  
 Note 4. For details on the bracket on the moving end of the cable track, refer to P. 90.

2D CAD

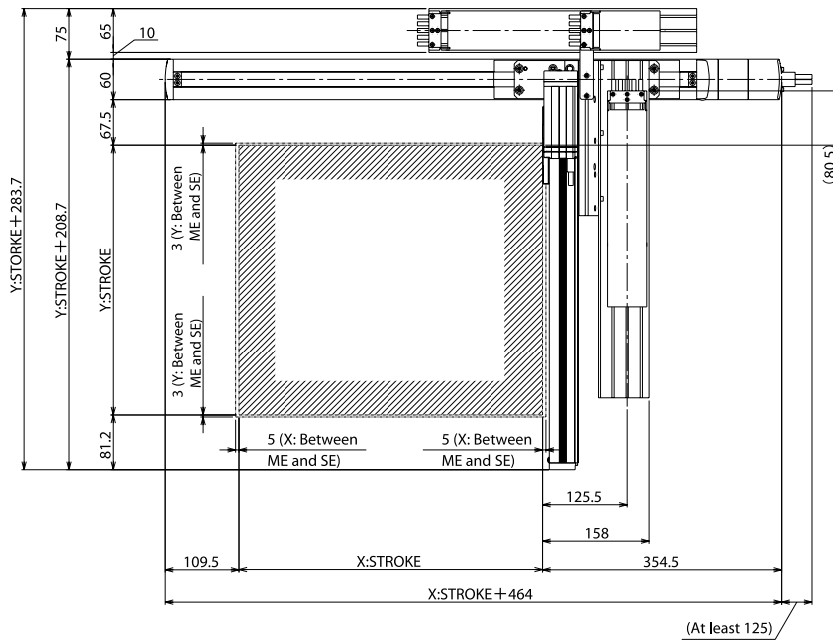
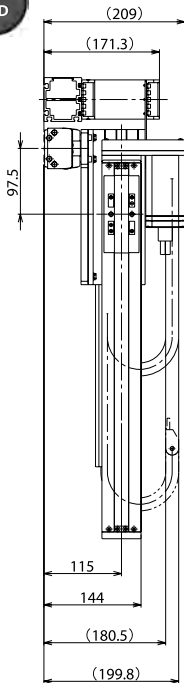

31  
 (Tolerance for reamed hole pitch: ±0.02)

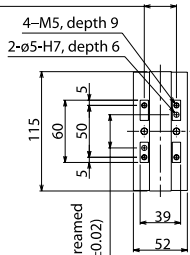

Detail view of Y-axis slider



Detail view of slot in bottom face of X-axis base

ME: Mechanical end  
 SE: Stroke end

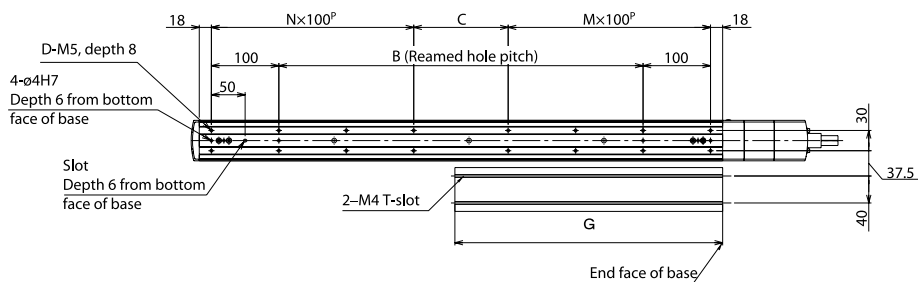
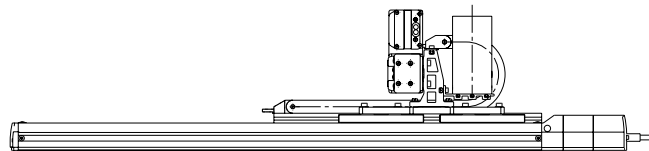

Detail view of X-axis installation

Dimensions by Stroke

	200	250	300	350	400	450	500	550	600
X: Nominal stroke	200	250	300	350	400	450	500	550	600
X: Effective stroke	50	100	150	200	250	300	350	400	450
B	140	190	240	290	340	390	440	490	540
C	140	190	40	90	140	190	40	90	140
D	8	8	12	12	12	12	16	16	16
M	1	1	2	2	2	2	3	3	3
N	1	1	2	2	2	2	3	3	3
G	197	222	247	272	297	322	347	372	397

Controllers

Applicable controller



Refer to P. 91 for the controllers.

# IK2-SXBB1□□S

RCS2 2-axis Combinations X axis: SS8R (100W, Reversed, Single-slider)  
Y axis: SA7R (Reversed)

**Model Details**

Series: **IK2** | Type: **SXBB1□□S** | Encoder type: **□** | Axis 1 (X axis): **□□□□** | Axis 2 (Y axis): **□□□□** | Controller: **□** | Cable: **□□□□** | Shipping configuration: **□**

**Combination directions 1-2**

**Differences between Single-slider and Double-slider Types**  
 HH: X high-speed, Y high-speed  
 MM: X medium-speed, Y medium-speed

**Encoder type**  
 I: Incremental  
 A: Absolute

**Stroke (mm)**  
 5: 50mm  
 (Can be set in 50-mm increments)

**Options**  
 NM: Opposite-home specification  
 SR: Slider roller specification

**Controllers**  
 T1: XSEL-J/K  
 T2: SSEL  
 XSEL-P/Q

**Cable length**  
 1L: 1m  
 3L: 3m  
 5L: 5m  
 □L: □m

**Wiring 1**  
 N: Cable only  
 CT: With cable track

**Wiring 2**

**Shipping configuration**  
 K: Individual components (kit)

\* Refer to P. 10 for details on the items comprising the model name.



Both wiring 1 and wiring 2 assume use of a cable track.

**Maximum Stroke**

**X axis** 1000 mm | **Y axis** 300 mm

**Maximum Speed**

	High-speed type	Medium-speed type
X axis	1000mm/s	500mm/s
Y axis	800mm/s	400mm/s

**Maximum Load Capacity**

Y-axis stroke	X high-speed, Y high-speed	X medium-speed, Y medium-speed
50mm	8.0kg	16kg
100mm	8.0kg	16kg
150mm	7.0kg	15kg
200mm	7.0kg	12.5kg
250mm	6.0kg	9.0kg
300mm	6.0kg	8.0kg

**List by Stroke**

Y-axis stroke	Incremental						Absolute					
	50	100	150	200	250	300	50	100	150	200	250	300
50	-	-	-	-	-	-	-	-	-	-	-	-
100	-	-	-	-	-	-	-	-	-	-	-	-
150	-	-	-	-	-	-	-	-	-	-	-	-
200	-	-	-	-	-	-	-	-	-	-	-	-
250	-	-	-	-	-	-	-	-	-	-	-	-
300	-	-	-	-	-	-	-	-	-	-	-	-
350	-	-	-	-	-	-	-	-	-	-	-	-
400	-	-	-	-	-	-	-	-	-	-	-	-
450	-	-	-	-	-	-	-	-	-	-	-	-
500	-	-	-	-	-	-	-	-	-	-	-	-
550	-	-	-	-	-	-	-	-	-	-	-	-
600	-	-	-	-	-	-	-	-	-	-	-	-
650	-	-	-	-	-	-	-	-	-	-	-	-
700	-	-	-	-	-	-	-	-	-	-	-	-
750	-	-	-	-	-	-	-	-	-	-	-	-
800	-	-	-	-	-	-	-	-	-	-	-	-
850	-	-	-	-	-	-	-	-	-	-	-	-
900	-	-	-	-	-	-	-	-	-	-	-	-
950	-	-	-	-	-	-	-	-	-	-	-	-
1000	-	-	-	-	-	-	-	-	-	-	-	-

**List by Cable Length**

Type	Cable code	Length
Standard type	1L	1m
	3L	3m
	5L	5m

\* Axis 1 comes with a standard cable, while axis 2 comes with a robot cable.  
 \* Refer to P. 90 for lengths other than those specified above.

**Cable track**

Wiring 1 (Next to X-axis)	X-axis stroke	50-300	350-600	650-900	950-1000
Wiring 2 (Next to Y-axis)	Y-axis stroke	50-200	250-300	-	-

**List of Options**

Name	Option code
Opposite-home specification	NM
Slider roller specification	SR

Axis 1 (X-axis)  
Axis 2 (Y-axis)

**Specifications**

Item	X axis	Y axis
Axis model	RCS2-SS8R	RCS2-SA7R
Stroke (Can be set in 50-mm increments)	50-1000mm	50-300mm
Max speed	Stroke	50-600mm
	High speed	650-700mm
	Medium speed	750-800mm
Motor output (W)	100W	60W
Ball screw lead	High-speed type: 20mm Medium-speed type: 10mm	High-speed type: 16mm Medium-speed type: 8mm
Drive method	Ball screw, ø16 mm, rolled, C10	Ball screw, ø12 mm, rolled, C10
Positioning repeatability	±0.02mm	
Base material	Dedicated alloy steel	Aluminum
Surrounding air temperature/humidity	0 to 40°C, 85% RH or below (non-condensing)	

Dimensions

You can download CAD drawings from our website. [www.intelligentactuator.com](http://www.intelligentactuator.com)

Note 1. The connected position shown in the drawing defines the home.  
 Note 2. Both wiring 1 and wiring 2 assume use of a cable track.  
 Note 3. For details on the cable track, refer to P. 90.  
 Note 4. For details on the bracket on the moving end of the cable track, refer to P. 90.

2D CAD

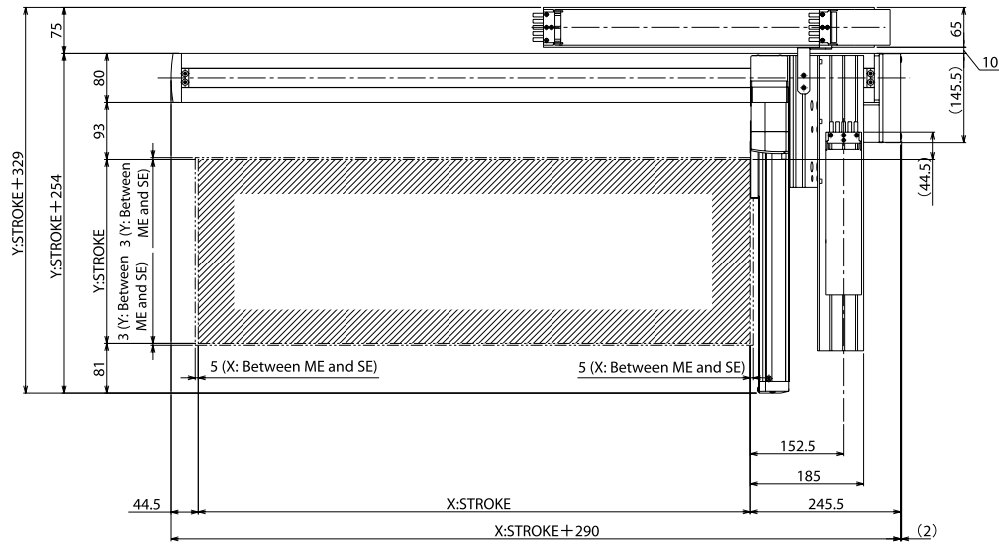
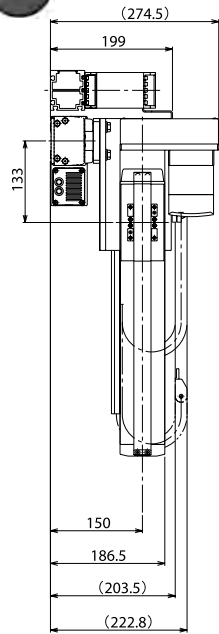

39  
 (Tolerance for reamed hole pitch: ±0.02)

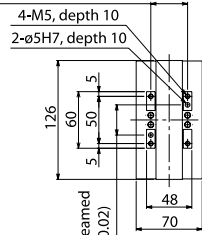

ME: Mechanical end  
 SE: Stroke end

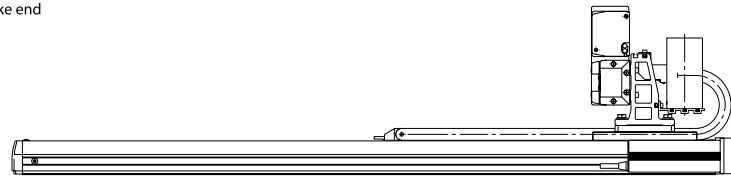

Detail view of Y-axis slider



Detail view of slot in bottom face of X-axis base

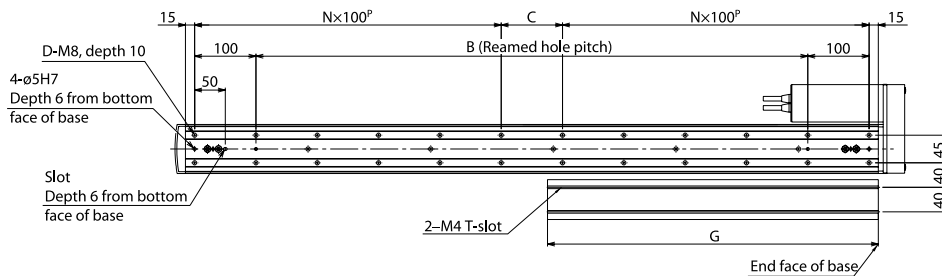

Detail view of X-axis installation

Dimensions by Stroke

X: Nominal stroke	50	100	150	200	250	300	350	400	450	500	550	600	650	700	750	800	850	900	950	1000
B	50	100	150	200	250	300	350	400	450	500	550	600	650	700	750	800	850	900	950	1000
C	50	100	150	0	50	100	150	0	50	100	150	0	50	100	150	0	50	100	150	0
D	8	8	8	10	12	12	12	14	16	16	16	18	20	20	20	22	24	24	24	26
N	1	1	1	2	2	2	2	3	3	3	3	4	4	4	4	5	5	5	5	6
G	114.5	139.5	164.5	189.5	214.5	239.5	264.5	289.5	314.5	339.5	364.5	389.5	414.5	439.5	464.5	489.5	514.5	539.5	564.5	589.5

Controllers

Applicable controller

Refer to P. 91 for the controllers.



# IK2-SXBB1□□D

RCS2 2-axis Combinations X axis: SS8R (100W, Reversed, Double-slider)  
Y axis: SA7R (Reversed)

**Model Details**

Series: IK2 — Type: SXBB1□□D — Encoder type: □ — Axis 1 (X axis): □ — Axis 2 (Y axis): □ — Controller: □ — Cable: □ — Shipping configuration: □

**Combination directions 1-2:** □ □

**Differences between Single-slider and Double-slider Types:**  
 HH: X high-speed, Y high-speed  
 MM: X medium-speed, Y medium-speed

**Encoder type:**  
 I: Incremental  
 A: Absolute

**Stroke (mm):** 5: 50mm  
 (Can be set in 50-mm increments)

**Options:**  
 NM: Opposite-home specification  
 SR: Slider roller specification

**Controllers:**  
 T1: XSEL-J/K  
 T2: SSEL  
 XSEL-P/Q

**Cable length:**  
 1L: 1m  
 3L: 3m  
 5L: 5m  
 □L: □m

**Wiring 1:** N: Cable only  
 CT: With cable track

**Wiring 2:** □

**Shipping configuration:** K: Individual components (kit)

\* Refer to P.10 for details on the items comprising the model name.

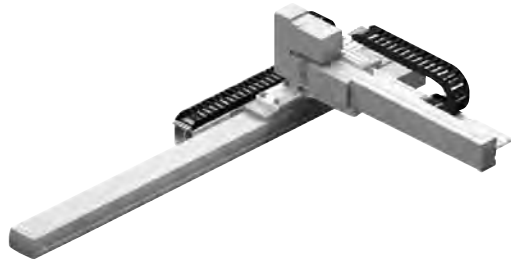

Both wiring 1 and wiring 2 assume use of a cable track.

**Maximum Stroke**

X axis 800 mm      Y axis 400 mm

**Maximum Speed**

	High-speed type	Medium-speed type
X axis	1000mm/s	500mm/s
Y axis	800mm/s	400mm/s

**Maximum Load Capacity**

Y-axis stroke	X high-speed, Y high-speed	X medium-speed, Y medium-speed
200mm	—	15kg
250mm	—	12.5kg
300mm	—	12.5kg
350mm	6.0kg	12kg
400mm	5.5kg	10.5kg

**List by Stroke**

Y-axis stroke	Incremental					Absolute				
	200	250	300	350	400	200	250	300	350	400
50	—	—	—	—	—	—	—	—	—	—
100	—	—	—	—	—	—	—	—	—	—
150	—	—	—	—	—	—	—	—	—	—
200	—	—	—	—	—	—	—	—	—	—
250	—	—	—	—	—	—	—	—	—	—
300	—	—	—	—	—	—	—	—	—	—
350	—	—	—	—	—	—	—	—	—	—
400	—	—	—	—	—	—	—	—	—	—
450	—	—	—	—	—	—	—	—	—	—
500	—	—	—	—	—	—	—	—	—	—
550	—	—	—	—	—	—	—	—	—	—
600	—	—	—	—	—	—	—	—	—	—
650	—	—	—	—	—	—	—	—	—	—
700	—	—	—	—	—	—	—	—	—	—
750	—	—	—	—	—	—	—	—	—	—
800	—	—	—	—	—	—	—	—	—	—

Note: For the X high-speed/Y high-speed type, the Y-axis stroke must be 350 mm or more.

**List by Cable Length**

Type	Cable code	Length
Standard type	1L	1m
	3L	3m
	5L	5m

\* Axis 1 comes with a standard cable, while axis 2 comes with a robot cable.

\* Refer to P.90 for lengths other than those specified above.

**Cable track**

Wiring 1 (Next to X-axis)	X-axis stroke	50-300	350-600	650-800
Wiring 2 (Next to Y-axis)	Y-axis stroke	200	250-400	—

**List of Options**

Name	Option code	
Opposite-home specification	NM	
Slider roller specification	SR	Axis 1 (X-axis) Axis 2 (Y-axis)

**Specifications**

Item	X axis	Y axis
Axis model	RCS2-SS8R	RCS2-SA7R
Stroke (Can be set in 50-mm increments)	50-800mm	High-speed type: 350-400mm Medium-speed type: 200-400mm
Max speed	Stroke High speed Medium speed	200-400mm 800mm/s 400mm/s
Motor output (W)	100W	60W
Ball screw lead	High-speed type: 20mm Medium-speed type: 10mm	High-speed type: 16mm Medium-speed type: 8mm
Drive method	Ball screw, ø16 mm, rolled, C10	Ball screw, ø12 mm, rolled, C10
Positioning repeatability	±0.02mm	
Base material	Dedicated alloy steel	Aluminum
Surrounding air temperature/humidity	0 to 40°C, 85% RH or below (non-condensing)	

Dimensions

You can download CAD drawings from our website. [www.intelligentactuator.com](http://www.intelligentactuator.com)

Note 1. The connected position shown in the drawing defines the home.  
 Note 2. Both wiring 1 and wiring 2 assume use of a cable track.  
 Note 3. For details on the cable track, refer to P. 90.  
 Note 4. For details on the bracket on the moving end of the cable track, refer to P. 90.

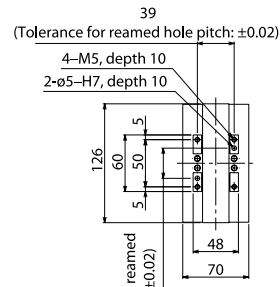
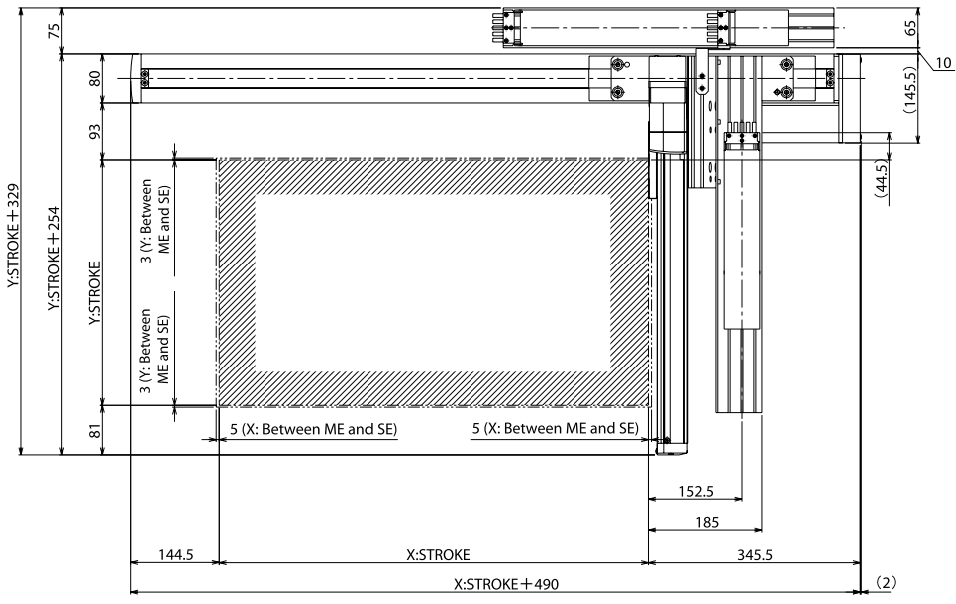
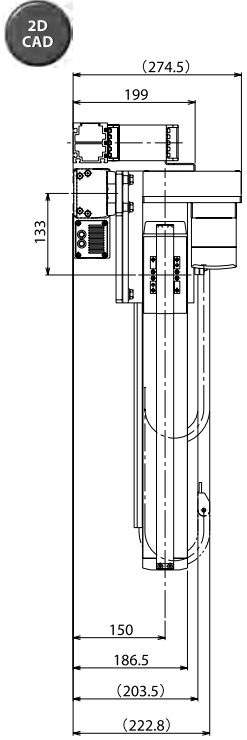

Detail view of Y-axis slider

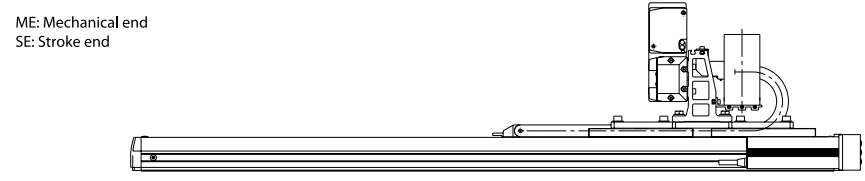

Detail view of slot in bottom face of X-axis base

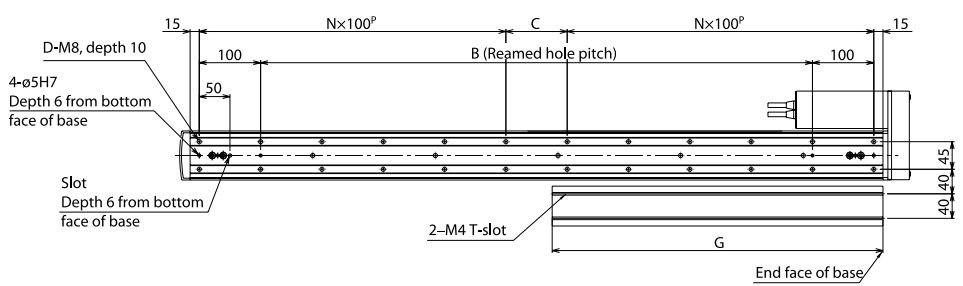

Detail view of X-axis installation

Dimensions by Stroke

X: Nominal stroke	250	300	350	400	450	500	550	600	650	700	750	800	850	900	950	1000
X: Effective stroke	50	100	150	200	250	300	350	400	450	500	550	600	650	700	750	800
B	250	300	350	400	450	500	550	600	650	700	750	800	850	900	950	1000
C	50	100	150	0	50	100	150	0	50	100	150	0	50	100	150	0
D	12	12	12	14	16	16	16	18	20	20	20	22	24	24	24	26
N	2	2	2	3	3	3	3	4	4	4	4	5	5	5	5	6
G	214.5	239.5	264.5	289.5	314.5	339.5	364.5	389.5	414.5	439.5	464.5	489.5	514.5	539.5	564.5	589.5

Controllers

Applicable controller

Refer to P. 91 for the controllers.

# IK2-SXBB2□□S

RCS2 2-axis Combinations X axis: SS8C (100W, Straight, Single-slider)  
Y axis: SA7R (Reversed)

2-axis Combinations RCP2  
2-axis Combinations RCS2  
3-axis Combinations RCP2  
3-axis Combinations RCS2  
Controllers

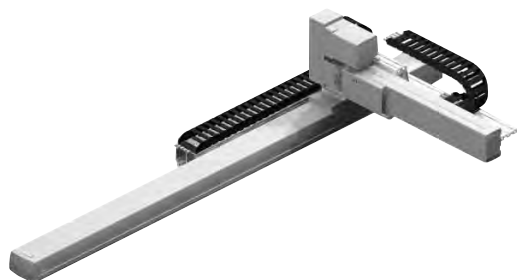
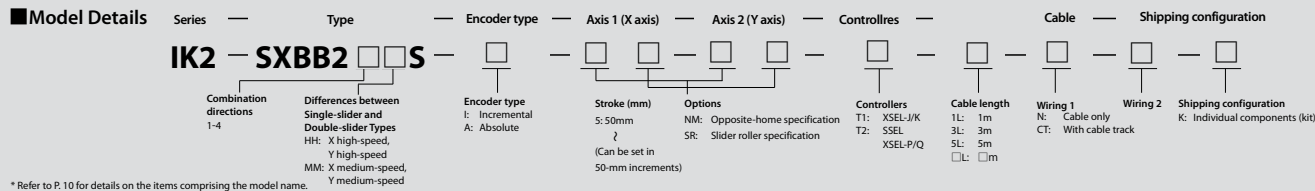

Both wiring 1 and wiring 2 assume use of a cable track.

**Maximum Stroke**

**X axis** 1000 mm      **Y axis** 300 mm

**Maximum Speed**

	High-speed type	Medium-speed type
X axis	1000mm/s	500mm/s
Y axis	800mm/s	400mm/s

**Maximum Load Capacity**

Y-axis stroke	X high-speed, Y high-speed	X medium-speed, Y medium-speed
50mm	8.0kg	16kg
100mm	8.0kg	16kg
150mm	7.0kg	15kg
200mm	7.0kg	12.5kg
250mm	6.0kg	9.0kg
300mm	6.0kg	8.0kg

**List by Stroke**

Y-axis stroke	Incremental						Absolute					
	50	100	150	200	250	300	50	100	150	200	250	300
50	-	-	-	-	-	-	-	-	-	-	-	-
100	-	-	-	-	-	-	-	-	-	-	-	-
150	-	-	-	-	-	-	-	-	-	-	-	-
200	-	-	-	-	-	-	-	-	-	-	-	-
250	-	-	-	-	-	-	-	-	-	-	-	-
300	-	-	-	-	-	-	-	-	-	-	-	-
350	-	-	-	-	-	-	-	-	-	-	-	-
400	-	-	-	-	-	-	-	-	-	-	-	-
450	-	-	-	-	-	-	-	-	-	-	-	-
500	-	-	-	-	-	-	-	-	-	-	-	-
550	-	-	-	-	-	-	-	-	-	-	-	-
600	-	-	-	-	-	-	-	-	-	-	-	-
650	-	-	-	-	-	-	-	-	-	-	-	-
700	-	-	-	-	-	-	-	-	-	-	-	-
750	-	-	-	-	-	-	-	-	-	-	-	-
800	-	-	-	-	-	-	-	-	-	-	-	-
850	-	-	-	-	-	-	-	-	-	-	-	-
900	-	-	-	-	-	-	-	-	-	-	-	-
950	-	-	-	-	-	-	-	-	-	-	-	-
1000	-	-	-	-	-	-	-	-	-	-	-	-

**List by Cable Length**

Type	Cable code	Length
Standard type	1L	1m
	3L	3m
	5L	5m

\* Axis 1 comes with a standard cable, while axis 2 comes with a robot cable.  
\* Refer to P.90 for lengths other than those specified above.

**Cable track**

Wiring 1 (Next to X-axis)	X-axis stroke	50-300	350-600	650-900	950-1000
Wiring 2 (Next to Y-axis)	Y-axis stroke	50-200	250-300	-	-

**List of Options**

Name	Option code	
Opposite-home specification	NM	
Slider roller specification	SR	Axis 1 (X-axis) Axis 2 (Y-axis)

**Specifications**

Item	X axis	Y axis
Axis model	RCS2-SS8C	RCS2-SA7R
Stroke (Can be set in 50-mm increments)	50-1000mm	50-300mm
Max speed	Stroke	50-600mm
	High speed	650-700mm
	Medium speed	750-800mm
Motor output (W)	100W	60W
Ball screw lead	High-speed type: 20mm Medium-speed type: 10mm	High-speed type: 16mm Medium-speed type: 8mm
Drive method	Ball screw, ø16 mm, rolled, C10	Ball screw, ø12 mm, rolled, C10
Positioning repeatability	±0.02mm	
Base material	Dedicated alloy steel	Aluminum
Surrounding air temperature/humidity	0 to 40°C, 85% RH or below (non-condensing)	

Dimensions

You can download CAD drawings from our website.

[www.intelligentactuator.com](http://www.intelligentactuator.com)

Note 1. The connected position shown in the drawing defines the home.  
 Note 2. Both wiring 1 and wiring 2 assume use of a cable track.  
 Note 3. For details on the cable track, refer to P. 90.  
 Note 4. For details on the bracket on the moving end of the cable track, refer to P. 90.

2D CAD

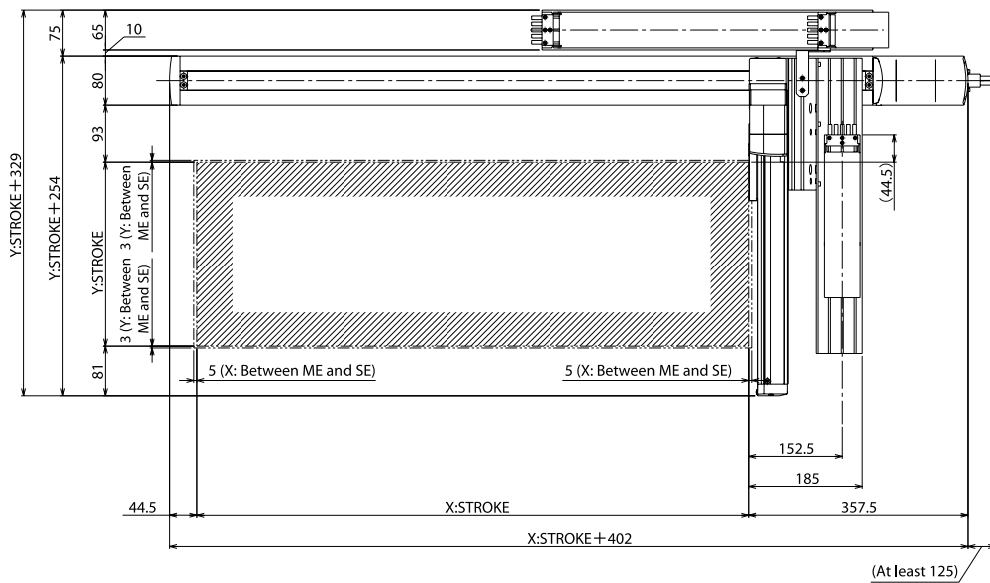
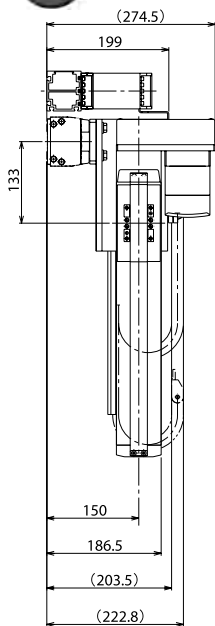

39  
 (Tolerance for reamed hole pitch: ±0.02)

4-M5, depth 10  
 2-ø5-H7, depth 10

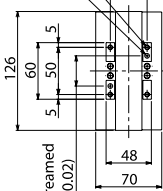

32  
 (Tolerance for reamed hole pitch: ±0.02)

ME: Mechanical end  
 SE: Stroke end

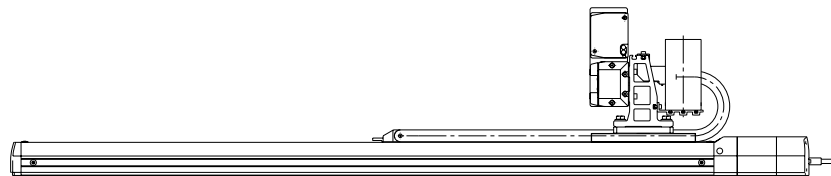

Detail view of Y-axis slider

4-ø5H7  
 Depth 6 from bottom face of base



Detail view of slot in bottom face of X-axis base

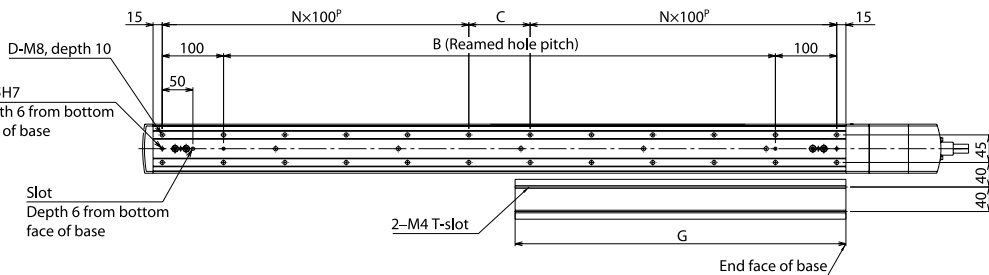

Detail view of X-axis installation

Dimensions by Stroke

X: Nominal stroke	50	100	150	200	250	300	350	400	450	500	550	600	650	700	750	800	850	900	950	1000	
B	50	100	150	200	250	300	350	400	450	500	550	600	650	700	750	800	850	900	950	1000	
C	50	100	150	0	50	100	150	0	50	100	150	0	50	100	150	0	50	100	150	0	
D	8	8	8	10	12	12	12	14	16	16	16	18	20	20	20	22	24	24	24	26	26
N	1	1	1	2	2	2	2	3	3	3	3	4	4	4	4	5	5	5	5	6	6
G	114.5	139.5	164.5	189.5	214.5	239.5	264.5	289.5	314.5	339.5	364.5	389.5	414.5	439.5	464.5	489.5	514.5	539.5	564.5	589.5	

Controllers

Applicable controller



Refer to P. 91 for the controllers.

# IK2-SXBB2□□D

RCS2 2-axis Combinations X axis: SS8C (100W, Straight, Double-slider)  
Y axis: SA7R (Reversed)

**Model Details**

Series: **IK2** Type: **SXBB2** Encoder type: **D**

Axis 1 (X axis): Stroke (mm) 5: 50mm, Options: NM: Opposite-home specification, SR: Slider roller specification (Can be set in 50-mm increments)

Axis 2 (Y axis): Cable length: 1L: 1m, 3L: 3m, 5L: 5m

Wiring 1: N: Cable only, CT: With cable track

Wiring 2: Shipping configuration: K: Individual components (kit)

\* Refer to P.10 for details on the items comprising the model name.

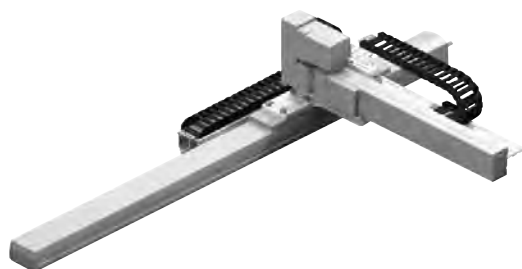

Both wiring 1 and wiring 2 assume use of a cable track.

**Maximum Stroke**

X axis **800 mm** Y axis **400 mm**

**Maximum Speed**

	High-speed type	Medium-speed type
X axis	1000mm/s	500mm/s
Y axis	800mm/s	400mm/s

**Maximum Load Capacity**

Y-axis stroke	X high-speed, Y high-speed	X medium-speed, Y medium-speed
200mm	—	15kg
250mm	—	12.5kg
300mm	—	12.5kg
350mm	6.0kg	12kg
400mm	5.5kg	10.5kg

**List by Stroke**

Y-axis stroke	Incremental					Absolute				
	200	250	300	350	400	200	250	300	350	400
50	—	—	—	—	—	—	—	—	—	—
100	—	—	—	—	—	—	—	—	—	—
150	—	—	—	—	—	—	—	—	—	—
200	—	—	—	—	—	—	—	—	—	—
250	—	—	—	—	—	—	—	—	—	—
300	—	—	—	—	—	—	—	—	—	—
350	—	—	—	—	—	—	—	—	—	—
400	—	—	—	—	—	—	—	—	—	—
450	—	—	—	—	—	—	—	—	—	—
500	—	—	—	—	—	—	—	—	—	—
550	—	—	—	—	—	—	—	—	—	—
600	—	—	—	—	—	—	—	—	—	—
650	—	—	—	—	—	—	—	—	—	—
700	—	—	—	—	—	—	—	—	—	—
750	—	—	—	—	—	—	—	—	—	—
800	—	—	—	—	—	—	—	—	—	—

Note: For the X high-speed/Y high-speed type, the Y-axis stroke must be 350 mm or more.

**List by Cable Length**

Type	Cable code	Length
Standard type	1L	1m
	3L	3m
	5L	5m

\* Axis 1 comes with a standard cable, while axis 2 comes with a robot cable.

\* Refer to P.90 for lengths other than those specified above.

**Cable track**

Wiring 1 (Next to X-axis)	X-axis stroke	50-300	350-600	650-800
Wiring 2 (Next to Y-axis)	Y-axis stroke	200	250-400	—

**List of Options**

Name	Option code
Opposite-home specification	NM
Slider roller specification	SR

**Specifications**

Item	X axis	Y axis
Axis model	RCS2-SS8C	RCS2-SA7R
Stroke (Can be set in 50-mm increments)	50-800mm	High-speed type: 350-400mm Medium-speed type: 200-400mm
Max speed	Stroke	200-400mm
	High speed	800mm/s
Motor output (W)	Medium speed	400mm/s
	100W	60W
Ball screw lead	High-speed type: 20mm Medium-speed type: 10mm	High-speed type: 16mm Medium-speed type: 8mm
Drive method	Ball screw, ø16 mm, rolled, C10	Ball screw, ø12 mm, rolled, C10
Positioning repeatability	±0.02mm	
Base material	Dedicated alloy steel	Aluminum
Surrounding air temperature/humidity	0 to 40°C, 85% RH or below (non-condensing)	

Dimensions

You can download CAD drawings from our website.

www.intelligentactuator.com

Note 1. The connected position shown in the drawing defines the home.  
 Note 2. Both wiring 1 and wiring 2 assume use of a cable track.  
 Note 3. For details on the cable track, refer to P.90.  
 Note 4. For details on the bracket on the moving end of the cable track, refer to P.90.

2D  
CAD

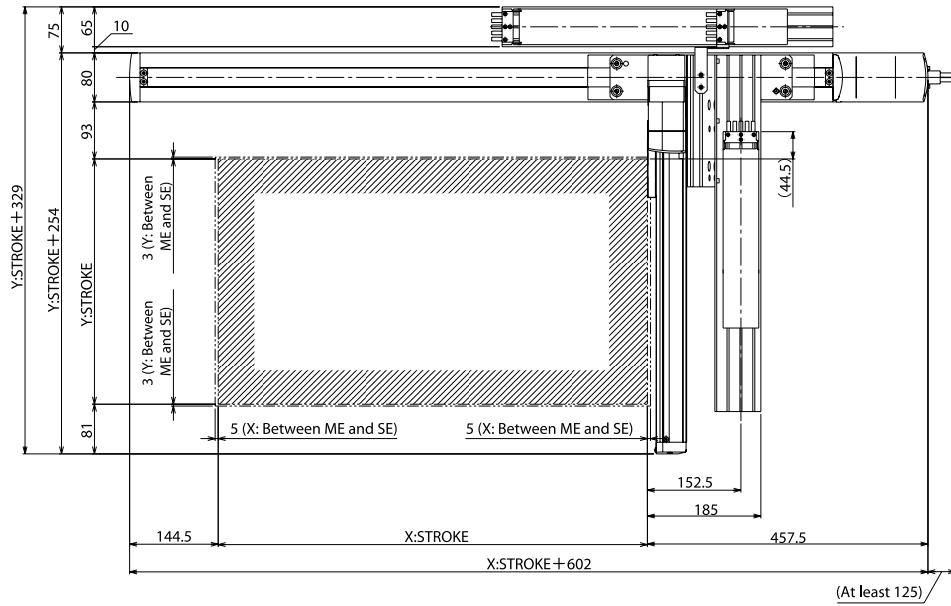
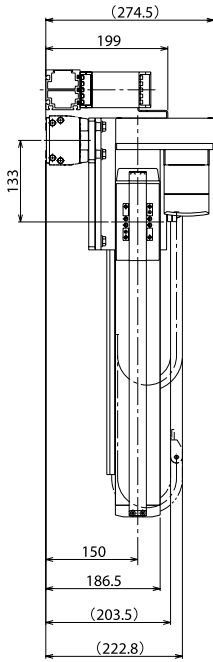

ME: Mechanical end  
 SE: Stroke end

39  
 (Tolerance for reamed hole pitch: ±0.02)

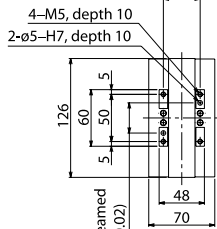

Detail view of Y-axis slider



Detail view of slot in bottom face of X-axis base

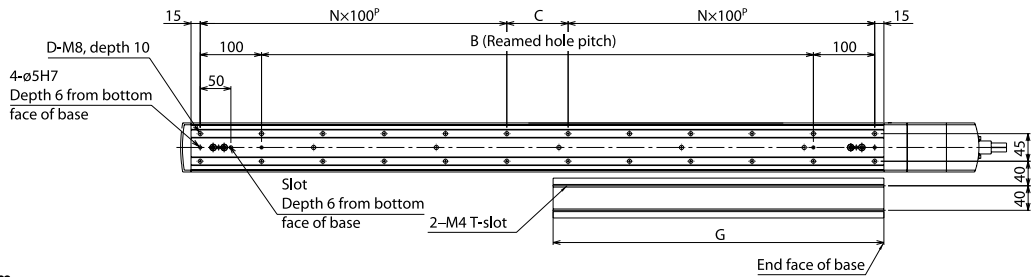
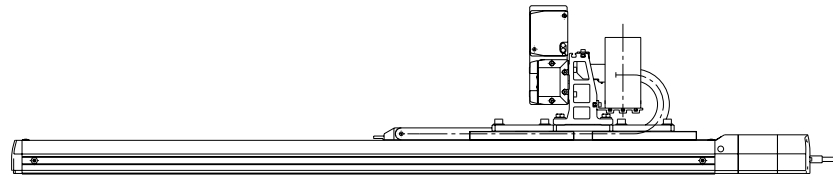

Detail view of X-axis installation

■ Dimensions by Stroke

X: Nominal stroke	250	300	350	400	450	500	550	600	650	700	750	800	850	900	950	1000
X: Effective stroke	50	100	150	200	250	300	350	400	450	500	550	600	650	700	750	800
B	250	300	350	400	450	500	550	600	650	700	750	800	850	900	950	1000
C	50	100	150	0	50	100	150	0	50	100	150	0	50	100	150	0
D	12	12	12	14	16	16	16	18	20	20	20	22	24	24	24	26
N	2	2	2	3	3	3	3	4	4	4	4	5	5	5	5	6
G	214.5	239.5	264.5	289.5	314.5	339.5	364.5	389.5	414.5	439.5	464.5	489.5	514.5	539.5	564.5	589.5

Controllers

Applicable controller



Refer to P. 91 for the controllers.

# IK2-SXBA1□□S

RCS2 2-axis Combinations X axis: SS8R (150W, Reversed, Single-slider)  
Y axis: SS8R (100W, Reversed)

**Model Details**

Series: IK2 — Type: SXBA1□□S — Encoder type: [ ] — Axis 1 (X axis): [ ] — Axis 2 (Y axis): [ ] — Controllres: [ ] — Cable: [ ] — Shipping configuration: [ ]

Combination directions T-Z  
Differences between Single-slider and Double-slider Types  
HH: X high-speed, Y high-speed  
MM: X medium-speed, Y medium-speed

Encoder type  
I: Incremental  
A: Absolute

Stroke (mm)  
5: 50mm  
(Can be set in 50-mm increments)

Options  
NM: Opposite-home specification  
SR: Slider roller specification

Controllers  
T1: XSEL-J/K  
T2: SSEL  
XSEL-P/Q

Cable length  
1L: 1m  
3L: 3m  
5L: 5m  
□L: □m

Wiring 1  
N: Cable only  
CT: With cable track

Wiring 2  
K: Individual components (kit)

\* Refer to P.10 for details on the items comprising the model name.



Both wiring 1 and wiring 2 assume use of a cable track.

**Maximum Stroke**

X axis 1000 mm      Y axis 350 mm

**Maximum Speed**

	High-speed type	Medium-speed type
X axis	1000mm/s	500mm/s
Y axis	1000mm/s	500mm/s

**Maximum Load Capacity**

Y-axis stroke	X high-speed, Y high-speed	X medium-speed, Y medium-speed
50mm	12kg	24kg
100mm	12kg	20.5kg
150mm	11.5kg	15.5kg
200mm	11kg	12.5kg
250mm	10kg	—
300mm	8.5kg	—
350mm	7kg	—

**List by Stroke**

Y-axis stroke	Incremental							Absolute						
	50	100	150	200	250	300	350	50	100	150	200	250	300	350
50	-	-	-	-	-	-	-	-	-	-	-	-	-	-
100	-	-	-	-	-	-	-	-	-	-	-	-	-	-
150	-	-	-	-	-	-	-	-	-	-	-	-	-	-
200	-	-	-	-	-	-	-	-	-	-	-	-	-	-
250	-	-	-	-	-	-	-	-	-	-	-	-	-	-
300	-	-	-	-	-	-	-	-	-	-	-	-	-	-
350	-	-	-	-	-	-	-	-	-	-	-	-	-	-
400	-	-	-	-	-	-	-	-	-	-	-	-	-	-
450	-	-	-	-	-	-	-	-	-	-	-	-	-	-
500	-	-	-	-	-	-	-	-	-	-	-	-	-	-
550	-	-	-	-	-	-	-	-	-	-	-	-	-	-
600	-	-	-	-	-	-	-	-	-	-	-	-	-	-
650	-	-	-	-	-	-	-	-	-	-	-	-	-	-
700	-	-	-	-	-	-	-	-	-	-	-	-	-	-
750	-	-	-	-	-	-	-	-	-	-	-	-	-	-
800	-	-	-	-	-	-	-	-	-	-	-	-	-	-
850	-	-	-	-	-	-	-	-	-	-	-	-	-	-
900	-	-	-	-	-	-	-	-	-	-	-	-	-	-
950	-	-	-	-	-	-	-	-	-	-	-	-	-	-
1000	-	-	-	-	-	-	-	-	-	-	-	-	-	-

Note: For the X medium-speed/Y medium-speed type, the Y-axis stroke must be 200 mm or less.

**List by Cable Length**

Type	Cable code	Length
Standard type	1L	1m
	3L	3m
	5L	5m

\* Axis 1 comes with a standard cable, while axis 2 comes with a robot cable.  
\* Refer to P.90 for lengths other than those specified above.

**Cable track**

Wiring 1 (Next to X-axis)	X-axis stroke	50-300	350-600	650-900	950-1000
Wiring 2 (Next to Y-axis)	Y-axis stroke	50-200	250-300	—	—

**List of Options**

Name	Option code	
Opposite-home specification	NM	
Slider roller specification	SR	Axis 1 (X-axis) Axis 2 (Y-axis)

**Specifications**

Item	X axis	Y axis
Axis model	RCS2-SS8R	RCS2-SS8R
Stroke (Can be set in 50-mm increments)	50-1000mm	High-speed type: 50-350mm Medium-speed type: 50-200mm
Max speed	Stroke	50-600mm
	High speed	650-700mm
Motor output (W)	Medium speed	750-800mm
	High speed	850-900mm
Ball screw lead	Medium speed	950-1000mm
	High speed	1000mm/s
Drive method	Medium speed	960mm/s
	High speed	480mm/s
Positioning repeatability	Medium speed	765mm/s
	High speed	380mm/s
Base material	Medium speed	625mm/s
	High speed	310mm/s
Surrounding air temperature/humidity	Medium speed	515mm/s
	High speed	255mm/s
	100W	100W
	High-speed type: 20mm Medium-speed type: 10mm	
	Ball screw, ø16 mm, rolled, C10	
	±0.02mm	
	Dedicated alloy steel	
	0 to 40°C, 85% RH or below (non-condensing)	

Dimensions

You can download CAD drawings from our website.

[www.intelligentactuator.com](http://www.intelligentactuator.com)

- Note 1. The connected position shown in the drawing defines the home.
- Note 2. Both wiring 1 and wiring 2 assume use of a cable track.
- Note 3. For details on the cable track, refer to P. 90.
- Note 4. For details on the bracket on the moving end of the cable track, refer to P. 90.

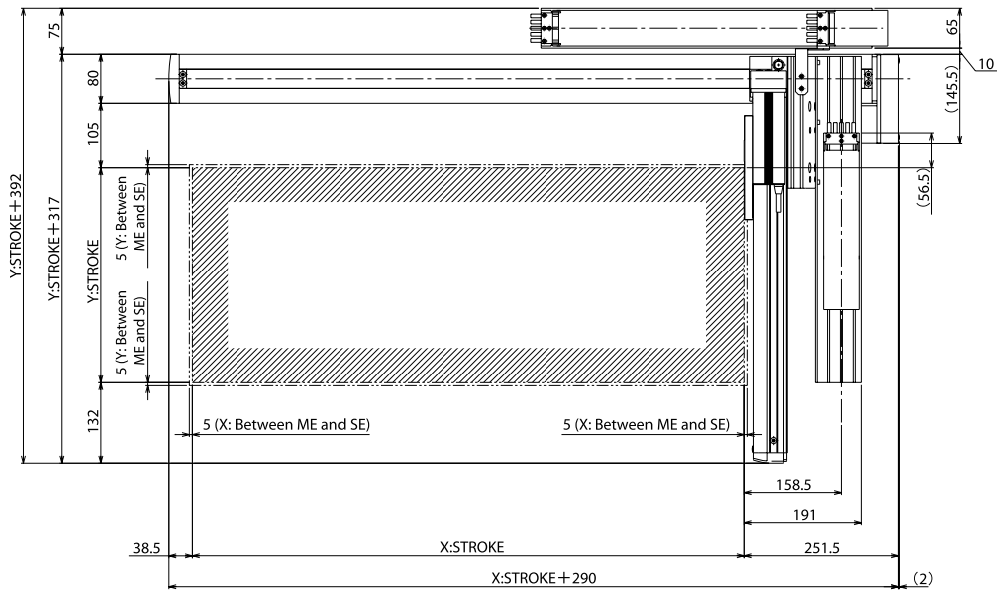
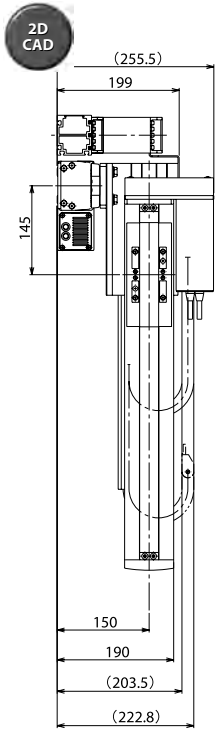

ME: Mechanical end  
SE: Stroke end

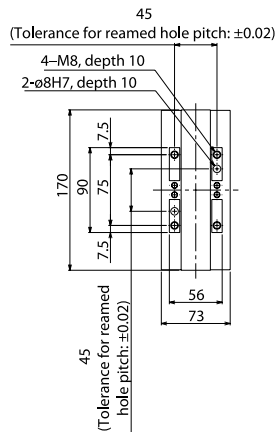

Detail view of Y-axis slider



Detail view of slot in bottom face of X-axis base

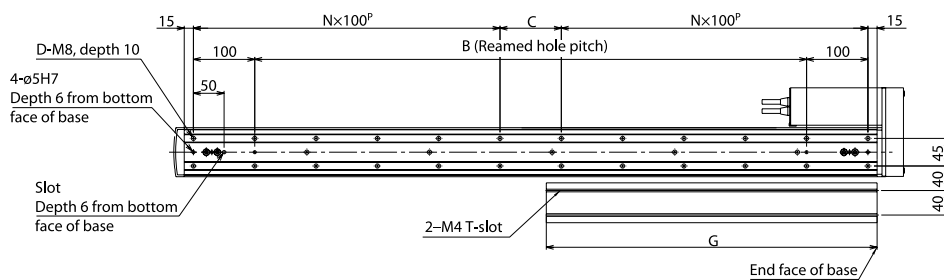
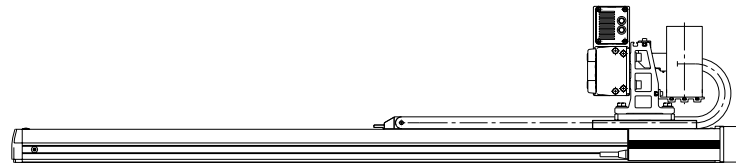

Detail view of X-axis installation

■ Dimensions by Stroke

X: Nominal stroke	50	100	150	200	250	300	350	400	450	500	550	600	650	700	750	800	850	900	950	1000
B	50	100	150	200	250	300	350	400	450	500	550	600	650	700	750	800	850	900	950	1000
C	50	100	150	0	50	100	150	0	50	100	150	0	50	100	150	0	50	100	150	0
D	8	8	8	10	12	12	12	14	16	16	16	18	20	20	20	22	24	24	24	26
N	1	1	1	2	2	2	2	3	3	3	3	4	4	4	4	5	5	5	5	6
G	114.5	139.5	164.5	189.5	214.5	239.5	264.5	289.5	314.5	339.5	364.5	389.5	414.5	439.5	464.5	489.5	514.5	539.5	564.5	589.5

Controllers

Applicable controller



Refer to P. 91 for the controllers.



# IK2-SXBA1□□D

RCS2 2-axis Combinations X axis: SS8R (150W, Reversed, Double-slider)  
Y axis: SS8R (100W, Reversed)

2-axis Combinations RCP2  
2-axis Combinations RCS2  
3-axis Combinations RCP2  
3-axis Combinations RCS2  
Controllers

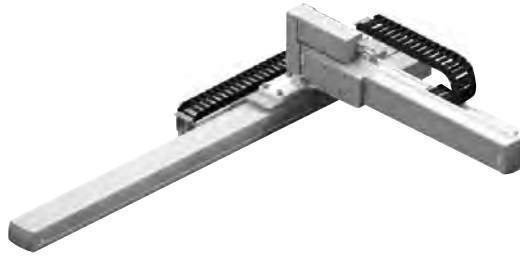
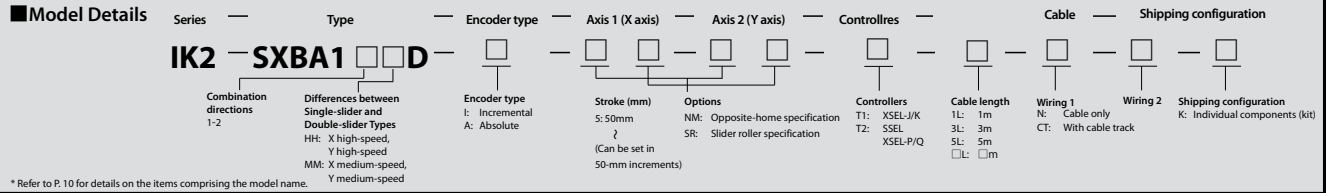

Both wiring 1 and wiring 2 assume use of a cable track.

**Maximum Stroke**

X axis 800 mm      Y axis 400 mm

**Maximum Speed**

	High-speed type	Medium-speed type
X axis	1000mm/s	500mm/s
Y axis	1000mm/s	500mm/s

**Maximum Load Capacity**

Y-axis stroke	X high-speed, Y high-speed	X medium-speed, Y medium-speed
100mm	—	24kg
150mm	—	24kg
200mm	—	23kg
250mm	—	19kg
300mm	11kg	16kg
350mm	10.5kg	13.5kg
400mm	10kg	11.5kg

**List by Stroke**

Y-axis stroke	Incremental								Absolute							
	100	150	200	250	300	350	400	100	150	200	250	300	350	400		
50	-	-	-	-	-	-	-	-	-	-	-	-	-	-		
100	-	-	-	-	-	-	-	-	-	-	-	-	-	-		
150	-	-	-	-	-	-	-	-	-	-	-	-	-	-		
200	-	-	-	-	-	-	-	-	-	-	-	-	-	-		
250	-	-	-	-	-	-	-	-	-	-	-	-	-	-		
300	-	-	-	-	-	-	-	-	-	-	-	-	-	-		
350	-	-	-	-	-	-	-	-	-	-	-	-	-	-		
400	-	-	-	-	-	-	-	-	-	-	-	-	-	-		
450	-	-	-	-	-	-	-	-	-	-	-	-	-	-		
500	-	-	-	-	-	-	-	-	-	-	-	-	-	-		
550	-	-	-	-	-	-	-	-	-	-	-	-	-	-		
600	-	-	-	-	-	-	-	-	-	-	-	-	-	-		
650	-	-	-	-	-	-	-	-	-	-	-	-	-	-		
700	-	-	-	-	-	-	-	-	-	-	-	-	-	-		
750	-	-	-	-	-	-	-	-	-	-	-	-	-	-		
800	-	-	-	-	-	-	-	-	-	-	-	-	-	-		

Note: For the X high-speed/Y high-speed type, the Y-axis stroke must be 300 mm or more.

**List by Cable Length**

Type	Cable code	Length
Standard type	1L	1m
	3L	3m
	5L	5m

\* Axis 1 comes with a standard cable, while axis 2 comes with a robot cable.  
\* Refer to P.90 for lengths other than those specified above.

**Cable track**

Wiring	X-axis stroke	50-300	350-600	650-800
Wiring 1 (Next to X-axis)				
Wiring 2 (Next to Y-axis)	Y-axis stroke	200	250-400	—

**List of Options**

Name	Option code	
Opposite-home specification	NM	
Slider roller specification	SR	Axis 1 (X-axis) Axis 2 (Y-axis)

**Specifications**

Item	X axis	Y axis
Axis model	RCS2-SS8R	RCS2-SS8R
Stroke (Can be set in 50-mm increments)	50-800mm	High-speed type: 300-400mm Medium speed type: 100-400mm
Max speed	Stroke High speed Medium speed	100-400mm
Motor output (W)	150W	100W
Ball screw lead	High-speed type: 20mm Medium-speed type: 10mm	
Drive method	Ball screw, ø16 mm, rolled, C10	
Positioning repeatability	±0.02mm	
Base material	Dedicated alloy steel	
Surrounding air temperature/humidity	0 to 40°C, 85% RH or below (non-condensing)	

Dimensions

You can download CAD drawings from our website. [www.intelligentactuator.com](http://www.intelligentactuator.com)

Note 1. The connected position shown in the drawing defines the home.  
 Note 2. Both wiring 1 and wiring 2 assume use of a cable track.  
 Note 3. For details on the cable track, refer to P.90.  
 Note 4. For details on the bracket on the moving end of the cable track, refer to P.90.

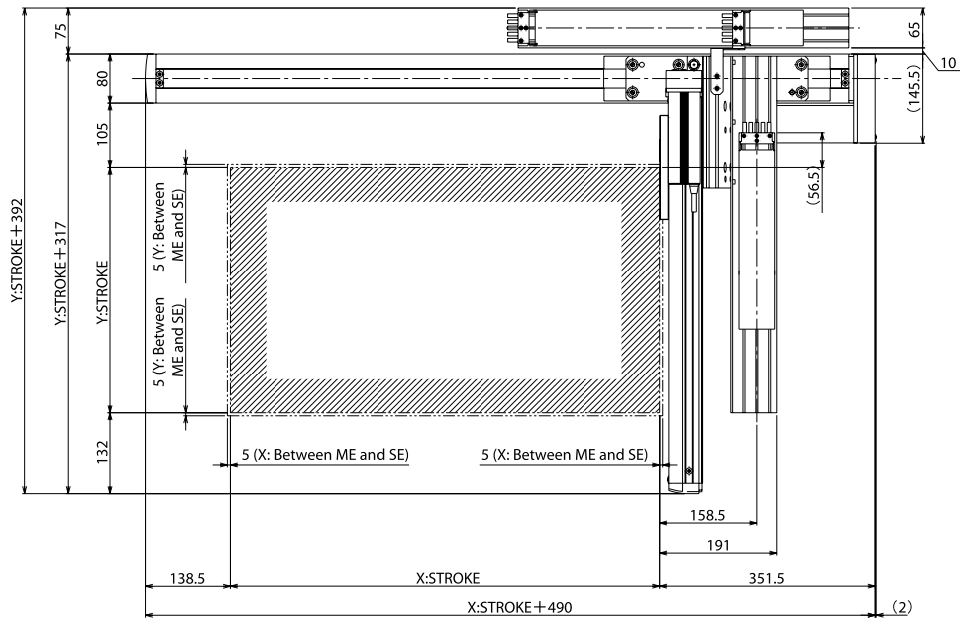
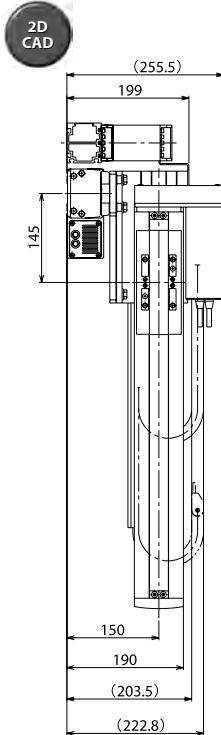

ME: Mechanical end  
 SE: Stroke end

45  
 (Tolerance for reamed hole pitch: ±0.02)

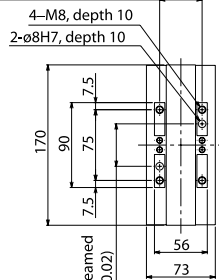

Detail view of Y-axis slider



Detail view of slot in bottom face of X-axis base

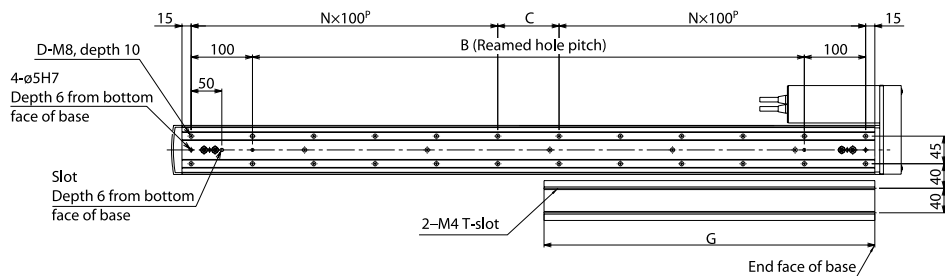
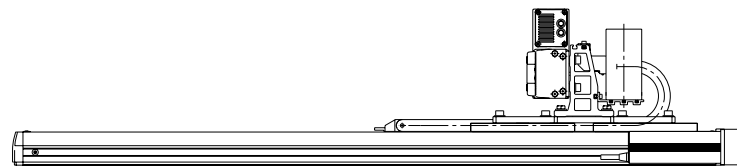

Detail view of X-axis installation

■ Dimensions by Stroke

X: Nominal stroke	250	300	350	400	450	500	550	600	650	700	750	800	850	900	950	1000
X: Effective stroke	50	100	150	200	250	300	350	400	450	500	550	600	650	700	750	800
B	250	300	350	400	450	500	550	600	650	700	750	800	850	900	950	1000
C	50	100	150	0	50	100	150	0	50	100	150	0	50	100	150	0
D	12	12	12	14	16	16	16	18	20	20	20	22	24	24	24	26
N	2	2	2	3	3	3	3	4	4	4	4	5	5	5	5	6
G	214.5	239.5	264.5	289.5	314.5	339.5	364.5	389.5	414.5	439.5	464.5	489.5	514.5	539.5	564.5	589.5

Controllers

Applicable controller

Refer to P. 91 for the controllers.

2-axis Combinations RCP2

2-axis Combinations RCS2

3-axis Combinations RCP2

3-axis Combinations RCS2

Controllers

# IK2-SXBA2□□S

RCS2 2-axis Combinations X axis: SS8C (150W, Straight, Single-slider)  
Y axis: SS8R (100W, Reversed)

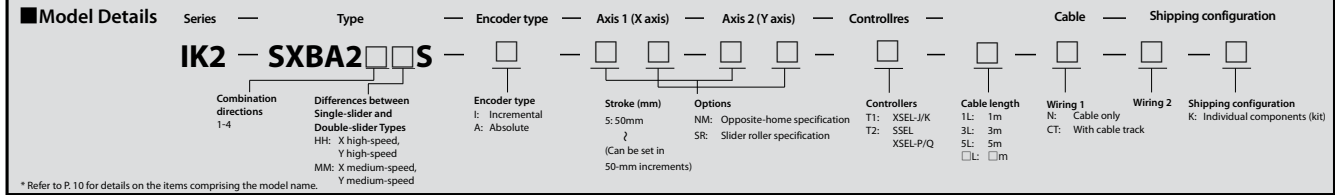

Both wiring 1 and wiring 2 assume use of a cable track.

**Maximum Stroke**

**X axis 1000 mm**      **Y axis 350 mm**

**Maximum Speed**

	High-speed type	Medium-speed type
X axis	1000mm/s	500mm/s
Y axis	1000mm/s	500mm/s

**Maximum Load Capacity**

	X high-speed, Y high-speed	X high-speed, Y high-speed	X medium-speed, Y medium-speed
50mm	12kg	12kg	24kg
100mm	12kg	12kg	20.5kg
150mm	11.5kg	11.5kg	15.5kg
200mm	11kg	11kg	12.5kg
250mm	10kg	10kg	—
300mm	8.5kg	8.5kg	—
350mm	7kg	7kg	—

**List by Stroke**

Y-axis stroke	Incremental							Absolute						
	50	100	150	200	250	300	350	50	100	150	200	250	300	350
50	-	-	-	-	-	-	-	-	-	-	-	-	-	-
100	-	-	-	-	-	-	-	-	-	-	-	-	-	-
150	-	-	-	-	-	-	-	-	-	-	-	-	-	-
200	-	-	-	-	-	-	-	-	-	-	-	-	-	-
250	-	-	-	-	-	-	-	-	-	-	-	-	-	-
300	-	-	-	-	-	-	-	-	-	-	-	-	-	-
350	-	-	-	-	-	-	-	-	-	-	-	-	-	-
400	-	-	-	-	-	-	-	-	-	-	-	-	-	-
450	-	-	-	-	-	-	-	-	-	-	-	-	-	-
500	-	-	-	-	-	-	-	-	-	-	-	-	-	-
550	-	-	-	-	-	-	-	-	-	-	-	-	-	-
600	-	-	-	-	-	-	-	-	-	-	-	-	-	-
650	-	-	-	-	-	-	-	-	-	-	-	-	-	-
700	-	-	-	-	-	-	-	-	-	-	-	-	-	-
750	-	-	-	-	-	-	-	-	-	-	-	-	-	-
800	-	-	-	-	-	-	-	-	-	-	-	-	-	-
850	-	-	-	-	-	-	-	-	-	-	-	-	-	-
900	-	-	-	-	-	-	-	-	-	-	-	-	-	-
950	-	-	-	-	-	-	-	-	-	-	-	-	-	-
1000	-	-	-	-	-	-	-	-	-	-	-	-	-	-

Note: For the X medium-speed/Y medium-speed type, the Y-axis stroke must be 200 mm or less.

**List by Cable Length**

Type	Cable code	Length
Standard type	1L	1m
	3L	3m
	5L	5m

\* Axis 1 comes with a standard cable, while axis 2 comes with a robot cable.  
 \* Refer to P. 90 for lengths other than those specified above.

**Cable track**

Wiring 1 (Next to X-axis)	X-axis stroke	50-300	350-600	650-900	950-1000
Wiring 2 (Next to Y-axis)	Y-axis stroke	50-200	250-300	—	—

**List of Options**

Name	Option code
Opposite-home specification	NM
Slider roller specification	SR

Axis 1 (X-axis)  
Axis 2 (Y-axis)

**Specifications**

Item	X axis	Y axis
Axis model	RCS2-SS8C	RCS2-SS8R
Stroke (Can be set in 50-mm increments)	50-1000mm	High-speed type: 50-350mm Medium speed type: 50-200mm
Max speed	Stroke	50-600mm
	High speed	650-700mm
	Medium speed	750-800mm
Motor output (W)	150W	100W
Ball screw lead	High-speed type: 20mm Medium-speed type: 10mm	
Drive method	Ball screw, ø16 mm, rolled, C10	
Positioning repeatability	±0.02mm	
Base material	Dedicated alloy steel	
Surrounding air temperature/humidity	0 to 40°C, 85% RH or below (non-condensing)	

Dimensions

You can download CAD drawings from our website.

www.intelligentactuator.com

Note 1. The connected position shown in the drawing defines the home.  
 Note 2. Both wiring 1 and wiring 2 assume use of a cable track.  
 Note 3. For details on the cable track, refer to P. 90.  
 Note 4. For details on the bracket on the moving end of the cable track, refer to P. 90.

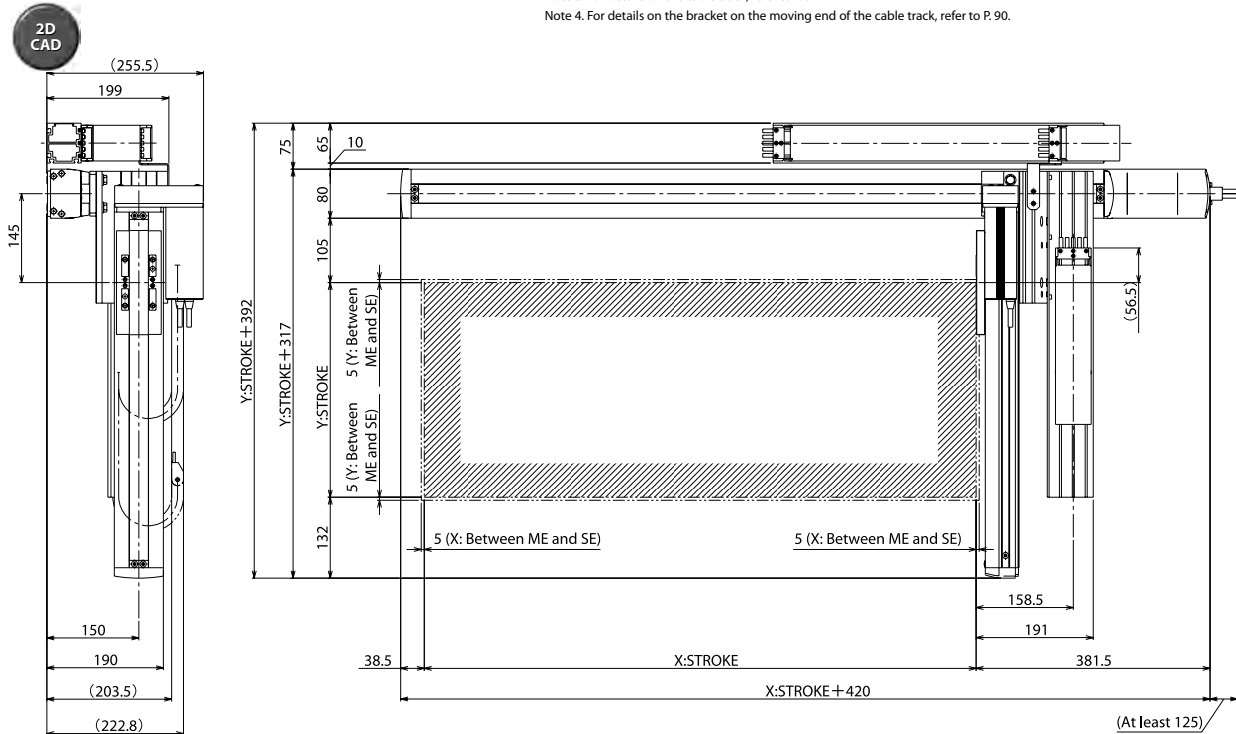

ME: Mechanical end  
 SE: Stroke end

45  
 (Tolerance for reamed hole pitch: ±0.02)  
 4-M8, depth 10  
 2-ø8-H7, depth 10

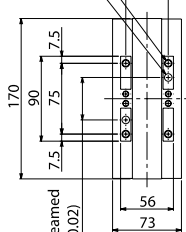

Detail view of Y-axis slider



Detail view of slot in bottom face of X-axis base

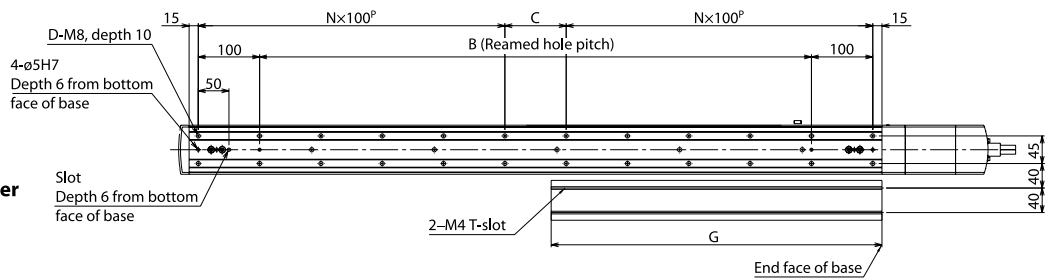
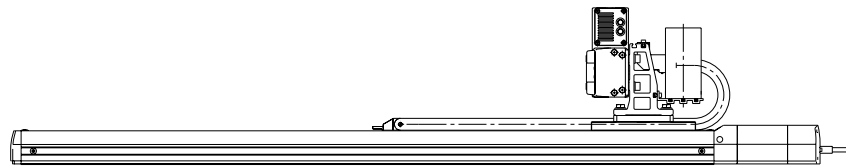

Detail view of X-axis installation

Dimensions by Stroke

X: Model	50	100	150	200	250	300	350	400	450	500	550	600	650	700	750	800	850	900	950	1000
B	50	100	150	200	250	300	350	400	450	500	550	600	650	700	750	800	850	900	950	1000
C	50	100	150	0	50	100	150	0	50	100	150	0	50	100	150	0	50	100	150	0
D	8	8	8	10	12	12	12	14	16	16	16	18	20	20	20	22	24	24	24	26
N	1	1	1	2	2	2	2	3	3	3	3	4	4	4	4	5	5	5	5	6
G	114.5	139.5	164.5	189.5	214.5	239.5	264.5	289.5	314.5	339.5	364.5	389.5	414.5	439.5	464.5	489.5	514.5	539.5	564.5	589.5

Controllers

Applicable controller

Refer to P. 91 for the controllers.

# IK2-SXBA2□□D

RCS2 2-axis Combinations X axis: SS8C (150W, Straight, Double-slider)  
Y axis: SS8R (100W, Reversed)

**Model Details**

Series: IK2 — Type: SXBA2□□D — Encoder type: □ — Axis 1 (X axis): □ — Axis 2 (Y axis): □ — Controller: □ — Cable: □ — Shipping configuration: □

**Combination directions** T-4

**Differences between Single-slider and Double-slider Types**  
 HH: X high-speed, Y high-speed  
 MM: X medium-speed, Y medium-speed

**Encoder type**  
 I: Incremental  
 A: Absolute

**Stroke (mm)**  
 S: 50mm  
 ? (Can be set in 50-mm increments)

**Options**  
 NM: Opposite-home specification  
 SR: Slider roller specification

**Controllers**  
 T1: XSEL-J/K  
 T2: SSEL  
 XSEL-P/Q

**Cable length**  
 1L: 1m  
 3L: 3m  
 5L: 5m  
 □L: □m

**Wiring 1**  
 N: Cable only  
 CT: With cable track

**Wiring 2**

**Shipping configuration**  
 K: Individual components (kit)

\* Refer to P.10 for details on the items comprising the model name.

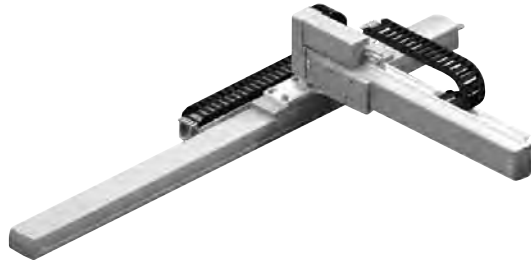

Both wiring 1 and wiring 2 assume use of a cable track.

**Maximum Stroke**

**X axis** 800 mm      **Y axis** 400 mm

**Maximum Speed**

	High-speed type	Medium-speed type
X axis	1000mm/s	500mm/s
Y axis	1000mm/s	500mm/s

**Maximum Load Capacity**

Y-axis stroke	X high-speed, Y high-speed	X medium-speed, Y medium-speed
100mm	—	24kg
150mm	—	24kg
200mm	—	23kg
250mm	—	19kg
300mm	11kg	16kg
350mm	10.5kg	13.5kg
400mm	10kg	11.5kg

**List by Stroke**

Y-axis stroke	Incremental								Absolute							
	100	150	200	250	300	350	400	100	150	200	250	300	350	400		
50	-	-	-	-	-	-	-	-	-	-	-	-	-	-		
100	-	-	-	-	-	-	-	-	-	-	-	-	-	-		
150	-	-	-	-	-	-	-	-	-	-	-	-	-	-		
200	-	-	-	-	-	-	-	-	-	-	-	-	-	-		
250	-	-	-	-	-	-	-	-	-	-	-	-	-	-		
300	-	-	-	-	-	-	-	-	-	-	-	-	-	-		
350	-	-	-	-	-	-	-	-	-	-	-	-	-	-		
400	-	-	-	-	-	-	-	-	-	-	-	-	-	-		
450	-	-	-	-	-	-	-	-	-	-	-	-	-	-		
500	-	-	-	-	-	-	-	-	-	-	-	-	-	-		
550	-	-	-	-	-	-	-	-	-	-	-	-	-	-		
600	-	-	-	-	-	-	-	-	-	-	-	-	-	-		
650	-	-	-	-	-	-	-	-	-	-	-	-	-	-		
700	-	-	-	-	-	-	-	-	-	-	-	-	-	-		
750	-	-	-	-	-	-	-	-	-	-	-	-	-	-		
800	-	-	-	-	-	-	-	-	-	-	-	-	-	-		

Note: For the X high-speed/Y high-speed type, the Y-axis stroke must be 300 mm or more.

**List by Cable Length**

Type	Cable code	Length
Standard type	1L	1m
	3L	3m
	5L	5m

\* Axis 1 comes with a standard cable, while axis 2 comes with a robot cable.  
 \* Refer to P.90 for lengths other than those specified above.

**Cable track**

Wiring 1 (Next to X-axis)	X-axis stroke	50-300	350-600	650-800
Wiring 2 (Next to Y-axis)	Y-axis stroke	200	250-400	—

**List of Options**

Name	Option code	
Opposite-home specification	NM	
Slider roller specification	SR	Axis 1 (X-axis) Axis 2 (Y-axis)

**Specifications**

Item	X axis	Y axis
Axis model	RCS2-SS8C	RCS2-SS8R
Stroke (Can be set in 50-mm increments)	50-800mm	High-speed type: 300-400mm Medium speed type: 100-400mm
Max speed	Stroke High speed Medium speed	100-400mm 1000mm/s 500mm/s
Motor output (W)	150W	100W
Ball screw lead	High-speed type: 20mm Medium-speed type: 10mm	
Drive method	Ball screw, ø16 mm, rolled, C10	
Positioning repeatability	±0.02mm	
Base material	Dedicated alloy steel	
Surrounding air temperature/humidity	0 to 40°C, 85% RH or below (non-condensing)	

Dimensions

You can download CAD drawings from our website. [www.intelligentactuator.com](http://www.intelligentactuator.com)

Note 1. The connected position shown in the drawing defines the home.  
 Note 2. Both wiring 1 and wiring 2 assume use of a cable track.  
 Note 3. For details on the cable track, refer to P. 90.  
 Note 4. For details on the bracket on the moving end of the cable track, refer to P. 90.

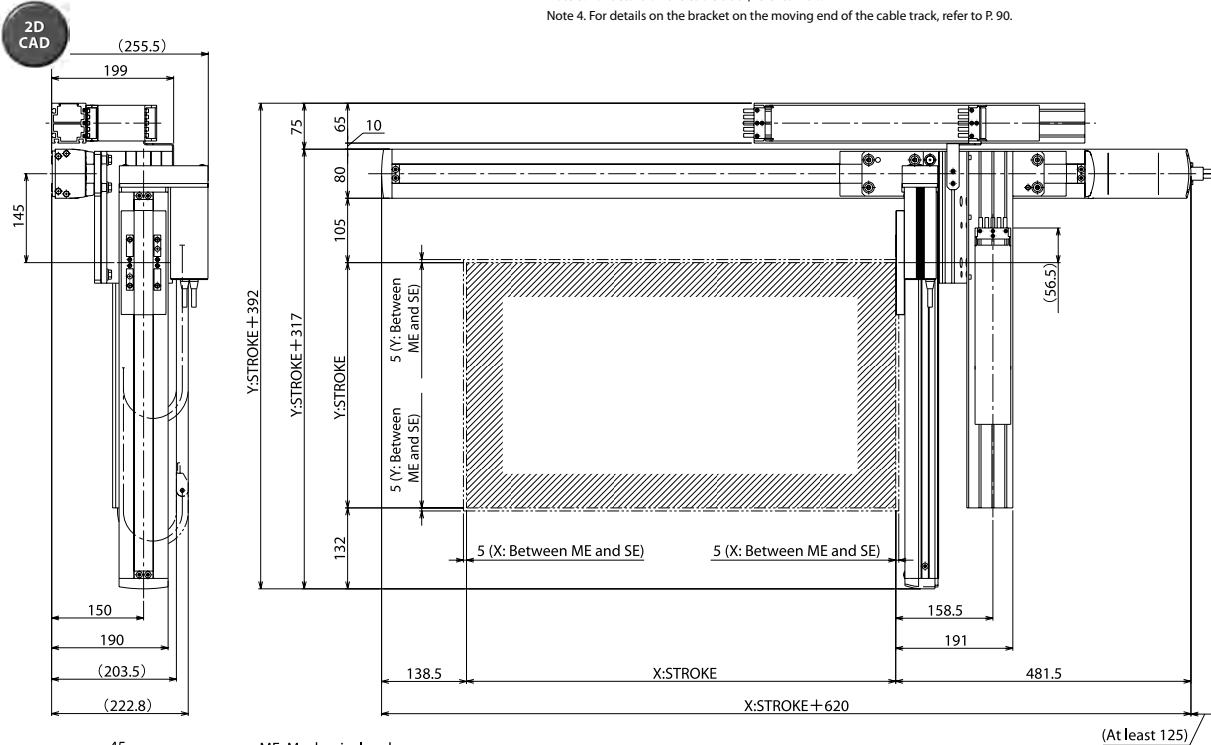

45  
 (Tolerance for reamed hole pitch: ±0.02) ME: Mechanical end  
 SE: Stroke end

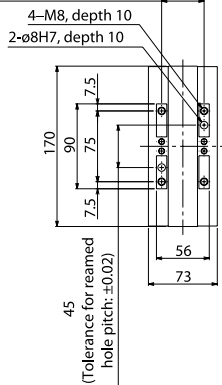

Detail view of Y-axis slider

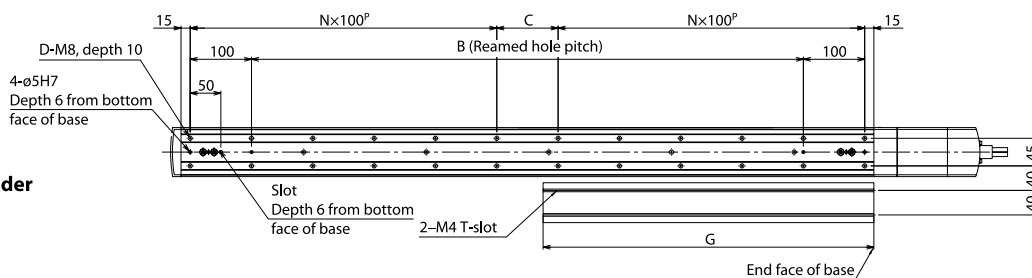
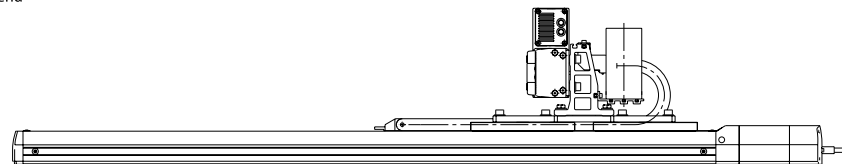

Detail view of X-axis installation

Detail view of slot in bottom face of X-axis base



■ Dimensions by Stroke

X: Nominal stroke	250	300	350	400	450	500	550	600	650	700	750	800	850	900	950	1000
X: Effective stroke	50	100	150	200	250	300	350	400	450	500	550	600	650	700	750	800
B	250	300	350	400	450	500	550	600	650	700	750	800	850	900	950	1000
C	50	100	150	0	50	100	150	0	50	100	150	0	50	100	150	0
D	12	12	12	14	16	16	16	18	20	20	20	22	24	24	24	26
N	2	2	2	3	3	3	3	4	4	4	4	5	5	5	5	6
G	214.5	239.5	264.5	289.5	314.5	339.5	364.5	389.5	414.5	439.5	464.5	489.5	514.5	539.5	564.5	589.5

Controllers

Applicable controller

☞ Refer to P. 91 for the controllers.

2-axis Combinations RCP2

2-axis Combinations RCS2

3-axis Combinations RCP2

3-axis Combinations RCS2

Controllers

# IK2-SXZB1□□S

RCS2 2-axis combination (XZ) X axis: S58R (100W, Reversed, Single-slider)  
Z axis: SA7R (Reversed)

**Model Details**

Series: **IK2** | Type: **SXZB1□□S** | Encoder type: **□** | Axis 1 (X axis): **□** | Axis 2 (Z axis): **B□** | Controller: **□** | Cable: **□** | Shipping configuration: **□**

**Encoder type**  
I: Incremental  
A: Absolute

**Stroke (mm)**  
5: 50mm  
□: (Can be set in 50-mm increments)

**Options**  
B: Brake  
NM: Opposite-home specification  
SR: Slider roller specification

**Controllers**  
T1: XSEL-J/K  
T2: SSEL  
XSEL-P/Q

**Cable length**  
1L: 1m  
3L: 3m  
5L: 5m  
□L: □m

**Wiring 1**  
N: Cable only  
CT: With cable track

**Wiring 2**  
□

**Shipping configuration**  
K: Individual components (kit)

**Differences between Single-slider and Double-slider Types**  
HH: X high-speed, Z high-speed  
HM: X high-speed, Z medium-speed  
HL: X high-speed, Z low-speed

**Combination directions**  
1-4

\* Refer to P.10 for details on the items comprising the model name.

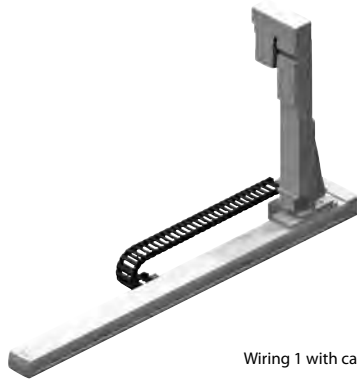

Wiring 1 with cable track

**Maximum Stroke**

**X axis** 1000 mm | **Z axis** 250 mm

**Maximum Speed**

	High-speed type	Medium-speed type	Low-speed type
X axis	1000mm/s	-	-
Z axis	800mm/s	400mm/s	200mm/s

**Maximum Load Capacity**

Z-axis stroke	Z-axis high-speed, lead 16	Z-axis medium-speed, lead 8	Z-axis low-speed, lead 4
50mm	2.0kg	4.0kg	8.0kg
100mm	2.0kg	4.0kg	7.0kg
150mm	2.0kg	3.5kg	5.0kg
200mm	2.0kg	3.5kg	4.0kg
250mm	1.5kg	2.5kg	3.0kg

**List by Stroke**

Z-axis stroke	Incremental					Absolute				
	50	100	150	200	250	50	100	150	200	250
50	-	-	-	-	-	-	-	-	-	-
100	-	-	-	-	-	-	-	-	-	-
150	-	-	-	-	-	-	-	-	-	-
200	-	-	-	-	-	-	-	-	-	-
250	-	-	-	-	-	-	-	-	-	-
300	-	-	-	-	-	-	-	-	-	-
350	-	-	-	-	-	-	-	-	-	-
400	-	-	-	-	-	-	-	-	-	-
450	-	-	-	-	-	-	-	-	-	-
500	-	-	-	-	-	-	-	-	-	-
550	-	-	-	-	-	-	-	-	-	-
600	-	-	-	-	-	-	-	-	-	-
650	-	-	-	-	-	-	-	-	-	-
700	-	-	-	-	-	-	-	-	-	-
750	-	-	-	-	-	-	-	-	-	-
800	-	-	-	-	-	-	-	-	-	-
850	-	-	-	-	-	-	-	-	-	-
900	-	-	-	-	-	-	-	-	-	-
950	-	-	-	-	-	-	-	-	-	-
1000	-	-	-	-	-	-	-	-	-	-

**List by Cable Length**

Type	Cable code	Length
Standard type	1L	1m
	3L	3m
	5L	5m

\* Axis 1 comes with a standard cable, while axis 2 comes with a robot cable.  
\* Refer to P.90 for lengths other than those specified above.

**Cable track**

Wiring 1 (Next to X-axis)	X-axis stroke	150-300	350-600	650-900	950-1000

**List of Options**

Name	Option code	
Opposite-home specification	NM	
Slider roller specification	SR	Axis 1 (X-axis) Axis 2 (Z-axis)

**Specifications**

Item	X axis	Z axis
Axis model	RCS2-S58R	RCS2-SA7R
Stroke (Can be set in 50-mm increments)	50-1000mm	50-250mm
Max speed	Stroke	50-600mm
	High speed	650-700mm
	Medium speed	750-800mm
	Low speed	850-900mm
Motor output (W)	100W	60W
Ball screw lead	High-speed type: 20mm	High-speed type: 16mm Medium-speed type: 8mm Low-speed type: 4mm
Drive method	Ball screw, ø16 mm, rolled, C10	Ball screw, ø12 mm, rolled, C10
Positioning repeatability	±0.02mm	
Base material	Dedicated alloy steel	Aluminum
Surrounding air temperature/humidity	0 to 40°C, 85% RH or below (non-condensing)	

Dimensions

You can download CAD drawings from our website.

[www.intelligentactuator.com](http://www.intelligentactuator.com)

2D CAD

Note 1. The connected position shown in the drawing defines the home.  
 Note 2. Both wiring 1 and wiring 2 assume use of a cable track.  
 Note 3. For details on the cable track, refer to P.90.  
 Note 4. For details on the bracket on the moving end of the cable track, refer to P.90.

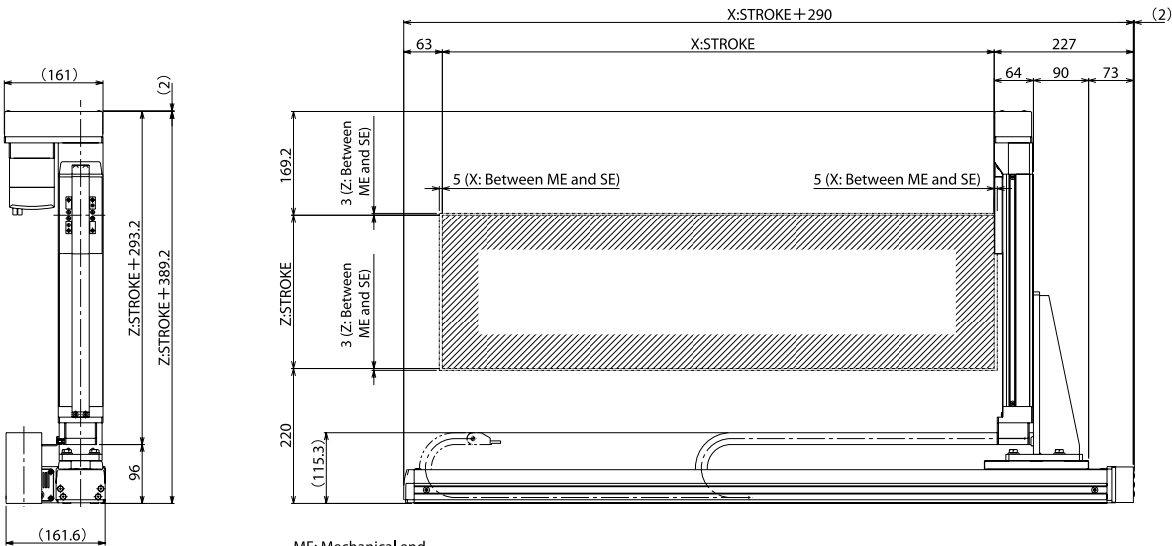
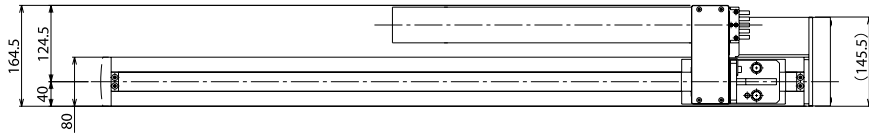

ME: Mechanical end  
 SE: Stroke end

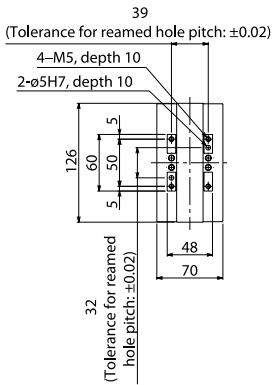

Detail view of Z-axis slider

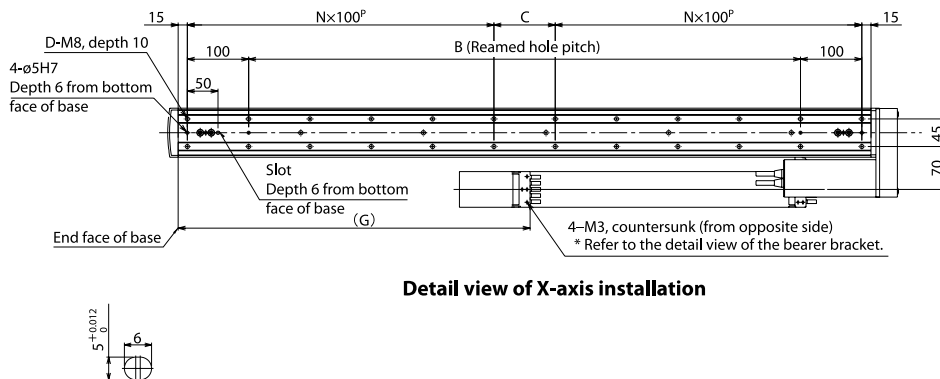

Detail view of slot in bottom face of X-axis base

Detail view of X-axis installation

Dimensions by Stroke

X: Model	50	100	150	200	250	300	350	400	450	500	550	600	650	700	750	800	850	900	950	1000
B	50	100	150	200	250	300	350	400	450	500	550	600	650	700	750	800	850	900	950	1000
C	50	100	150	0	50	100	150	0	50	100	150	0	50	100	150	0	50	100	150	0
D	8	8	8	10	12	12	12	14	16	16	16	18	20	20	20	22	24	24	24	26
N	1	1	1	2	2	2	2	3	3	3	3	4	4	4	4	5	5	5	5	6
G	-	-	199	224	249	274	299	324	349	374	399	424	449	474	499	524	549	574	599	624

\* A bearer is not set when the X stroke is 50 or 100.

Controllers

Applicable controller



Refer to P. 91 for the controllers.



# IK2-SXZB1 D

RCS2 2-axis Combinations(XZ)

X axis: SS8R (100W, Reversed, Double-slider)

Z axis: SA7R (Reversed)

**Model Details**

Series: **IK2** — Type: **SXZB1**   **D** — Encoder type:  — Axis 1 (X axis):  — Axis 2 (Z axis):  **B**  — Controllres:  — Cable:  — Shipping configuration:

**Combination directions** T-4

**Differences between Single-slider and Double-slider Types**  
 HH: X high-speed, Z high-speed  
 HM: X high-speed, Z medium-speed  
 HL: X high-speed, Z low-speed

**Encoder type**  
 I: Incremental  
 A: Absolute

**Stroke (mm)**  
 5-50mm  
 (Can be set in 50-mm increments)

**Options**  
 B: Brake  
 NM: Opposite-home specification  
 SR: Slider roller specification

**Controllres**  
 T1: XSEL-J/K  
 T2: SSEL  
 XSEL-P/Q

**Cable length**  
 1L: 1m  
 3L: 3m  
 5L: 5m  
 L:  m

**Wiring 1**  
 N: Cable only  
 CT: With cable track

**Wiring 2**

**Shipping configuration**  
 K: Individual components (kit)

\* Refer to P.10 for details on the items comprising the model name.



Wiring 1 with cable track

**Maximum Stroke**

**X axis** 800 mm

**Z axis** 300 mm

**Maximum Speed**

	High-speed type	Medium-speed type	Low-speed type
X axis	1000mm/s	-	-
Z axis	800mm/s	400mm/s	200mm/s

**Maximum Load Capacity**

Z-axis stroke	Z-axis high-speed, lead 16	Z-axis medium-speed, lead 8	Z-axis low-speed, lead 4
150mm	-	-	7.0kg
200mm	-	-	7.0kg
250mm	-	-	5.5kg
300mm	1.5kg	3.0kg	5.5kg

**List by Stroke**

Y-axis stroke	Incremental				Absolute			
	150	200	250	300	150	200	250	300
50	-	-	-	-	-	-	-	-
100	-	-	-	-	-	-	-	-
150	-	-	-	-	-	-	-	-
200	-	-	-	-	-	-	-	-
250	-	-	-	-	-	-	-	-
300	-	-	-	-	-	-	-	-
350	-	-	-	-	-	-	-	-
400	-	-	-	-	-	-	-	-
450	-	-	-	-	-	-	-	-
500	-	-	-	-	-	-	-	-
550	-	-	-	-	-	-	-	-
600	-	-	-	-	-	-	-	-
650	-	-	-	-	-	-	-	-
700	-	-	-	-	-	-	-	-
750	-	-	-	-	-	-	-	-
800	-	-	-	-	-	-	-	-

Note: For the Z high-speed type and Z medium-speed type, The Z-axis stroke is limited to 300 mm.

**List by Cable Length**

Type	Cable code	Length
Standard type	1L	1m
	3L	3m
	5L	5m

\* Axis 1 comes with a standard cable, while axis 2 comes with a robot cable.  
 \* Refer to P.90 for lengths other than those specified above.

**Cable track**

Wiring 1 (Next to X-axis)	X-axis stroke	150-300	350-600	650-800

**List of Options**

Name	Option code	
Opposite-home specification	NM	
Slider roller specification	SR	Axis 1 (X-axis) Axis 2 (Z-axis)

**Specifications**

Item	X axis	Z axis
Axis model	RCS2-SS8R	RCS2-SA7R
Stroke (Can be set in 50-mm increments)	50-800mm	High-speed type: 300mm Medium-speed type: 300mm Low-speed type: 150-300mm
Max speed	Stroke High speed Medium speed Low speed	150-300mm 800mm/s 400mm/s 200mm/s
Motor output (W)	100W	60W
Ball screw lead	High-speed type: 20mm	High-speed type: 16mm Medium-speed type: 8mm Low-speed type: 4mm
Drive method	Ball screw, ø16 mm, rolled, C10	Ball screw, ø12 mm, rolled, C10
Positioning repeatability	±0.02mm	
Base material	Dedicated alloy steel	Aluminum
Surrounding air temperature/humidity	0 to 40°C, 85% RH or below (non-condensing)	

Dimensions

You can download CAD drawings from our website.

[www.intelligentactuator.com](http://www.intelligentactuator.com)

2D CAD

Note 1. The connected position shown in the drawing defines the home.  
 Note 2. Both wiring 1 and wiring 2 assume use of a cable track.  
 Note 3. For details on the cable track, refer to P. 90.  
 Note 4. For details on the bracket on the moving end of the cable track, refer to P. 90.

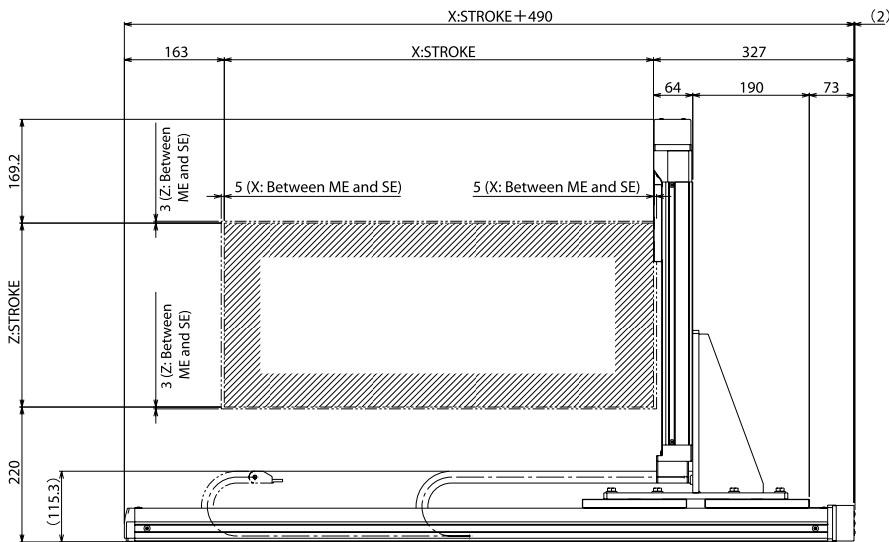
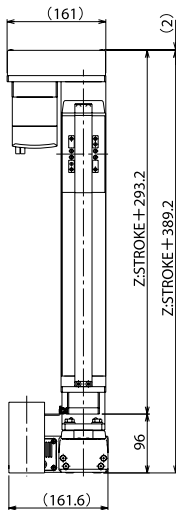
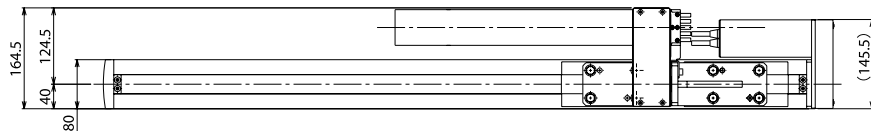

ME: Mechanical end  
 SE: Stroke end

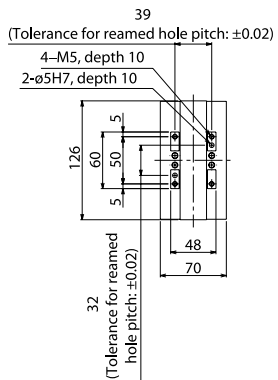

Detail view of Z-axis slider

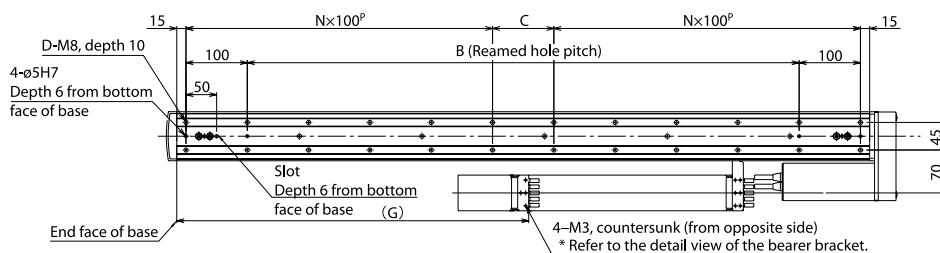

Detail view of X-axis installation



Detail view of slot in bottom face of X-axis base

Dimensions by Stroke

X: Nominal stroke	250	300	350	400	450	500	550	600	650	700	750	800	850	900	950	1000
X: Effective stroke	50	100	150	200	250	300	350	400	450	500	550	600	650	700	750	800
B	250	300	350	400	450	500	550	600	650	700	750	800	850	900	950	1000
C	50	100	150	0	50	100	150	0	50	100	150	0	50	100	150	0
D	12	12	12	14	16	16	16	18	20	20	20	22	24	24	24	26
N	2	2	2	3	3	3	3	4	4	4	4	5	5	5	5	6
G	-	-	299	324	349	374	399	424	449	474	499	524	549	574	599	624

\* A bearer is not set when the X stroke is 50 or 100.

Controllers

Applicable controller



Refer to P. 91 for the controllers.

# IK2-SYBB1□□S

RCS2 2-axis combination (YZ) Y axis: SS8R (100W, Reversed, Single-slider)  
Z axis: SA7R (Reversed)

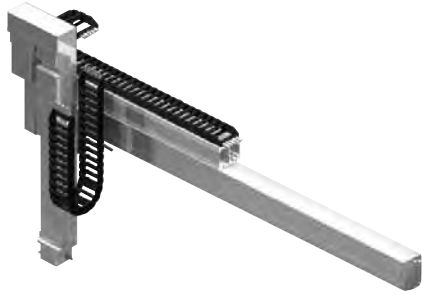
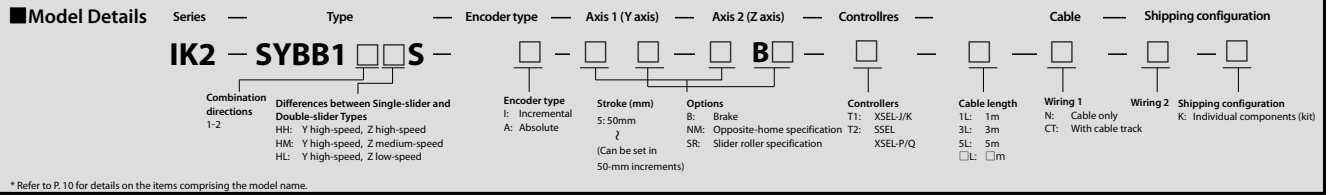

Both wiring 1 and wiring 2 assume use of a cable track.

**Maximum Stroke**

**Y axis** 1000 mm      **Z axis** 300 mm

**Maximum Speed**

	High-speed type	Medium-speed type	Low-speed type
Y axis	1000mm/s	-	-
Z axis	800mm/s	400mm/s	200mm/s

**Maximum Load Capacity**

Z-axis stroke	Z-axis high-speed, lead 16	Z-axis medium-speed, lead 8	Z-axis low-speed, lead 4
50mm	2.0kg	4.0kg	8.0kg
100mm	2.0kg	4.0kg	8.0kg
150mm	2.0kg	3.5kg	7.0kg
200mm	2.0kg	3.5kg	7.0kg
250mm	1.5kg	3.0kg	6.0kg
300mm	1.5kg	3.0kg	5.5kg

**List by Stroke**

Z-axis stroke	Incremental						Absolute					
	50	100	150	200	250	300	50	100	150	200	250	300
50	-	-	-	-	-	-	-	-	-	-	-	-
100	-	-	-	-	-	-	-	-	-	-	-	-
150	-	-	-	-	-	-	-	-	-	-	-	-
200	-	-	-	-	-	-	-	-	-	-	-	-
250	-	-	-	-	-	-	-	-	-	-	-	-
300	-	-	-	-	-	-	-	-	-	-	-	-
350	-	-	-	-	-	-	-	-	-	-	-	-
400	-	-	-	-	-	-	-	-	-	-	-	-
450	-	-	-	-	-	-	-	-	-	-	-	-
500	-	-	-	-	-	-	-	-	-	-	-	-
550	-	-	-	-	-	-	-	-	-	-	-	-
600	-	-	-	-	-	-	-	-	-	-	-	-
650	-	-	-	-	-	-	-	-	-	-	-	-
700	-	-	-	-	-	-	-	-	-	-	-	-
750	-	-	-	-	-	-	-	-	-	-	-	-
800	-	-	-	-	-	-	-	-	-	-	-	-
850	-	-	-	-	-	-	-	-	-	-	-	-
900	-	-	-	-	-	-	-	-	-	-	-	-
950	-	-	-	-	-	-	-	-	-	-	-	-
1000	-	-	-	-	-	-	-	-	-	-	-	-

**List by Cable Length**

Type	Cable code	Length
Standard type	1L	1m
	3L	3m
	5L	5m

\* Axis 1 comes with a standard cable, while axis 2 comes with a robot cable.  
 \* Refer to P. 90 for lengths other than those specified above.

**Cable track**

Wiring 1 (Next to Y-axis)	Y-axis stroke	50-300	350-600	650-900	950-1000
Wiring 2 (Next to Z-axis)	Z-axis stroke	50-200	250-300	-	-

**List of Options**

Name	Option code	
Opposite-home specification	<b>NM</b>	
Slider roller specification	<b>SR</b>	Axis 1 (Y-axis) Axis 2 (Z-axis)

**Specifications**

Item	Y axis	Z axis
Axis model	RCS2-SS8R	RCS2-SA7R
Stroke (Can be set in 50-mm increments)	50-1000mm	50-300mm
Max speed	Stroke	50-600mm
	High speed	650-700mm
	Medium speed	750-800mm
	Low speed	850-900mm
Motor output (W)	100W	60W
Ball screw lead	High-speed type: 20mm	High-speed type: 16mm Medium-speed type: 8mm Low-speed type: 4mm
Drive method	Ball screw, ø16 mm, rolled, C10	Ball screw, ø12 mm, rolled, C10
Positioning repeatability	±0.02mm	
Base material	Dedicated alloy steel	Aluminum
Surrounding air temperature/humidity	0 to 40°C, 85% RH or below (non-condensing)	

Dimensions

You can download CAD drawings from our website.

www.intelligentactuator.com

2D CAD

- Note 1. The connected position shown in the drawing defines the home.
- Note 2. Both wiring 1 and wiring 2 assume use of a cable track.
- Note 3. For details on the cable track, refer to P. 90.
- Note 4. For details on the bracket on the moving end of the cable track, refer to P. 90.

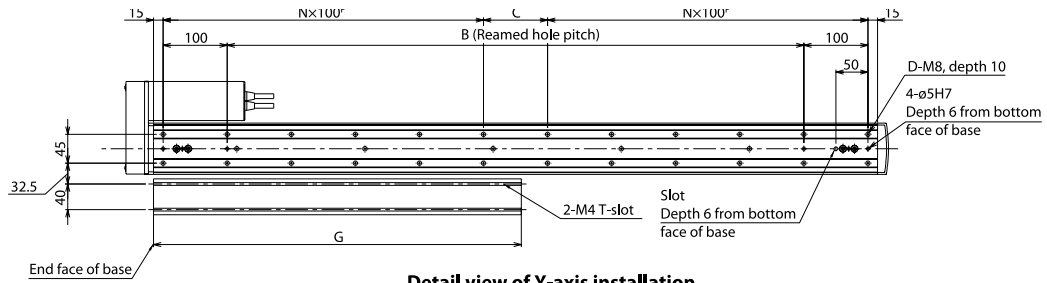

Detail view of Y-axis installation

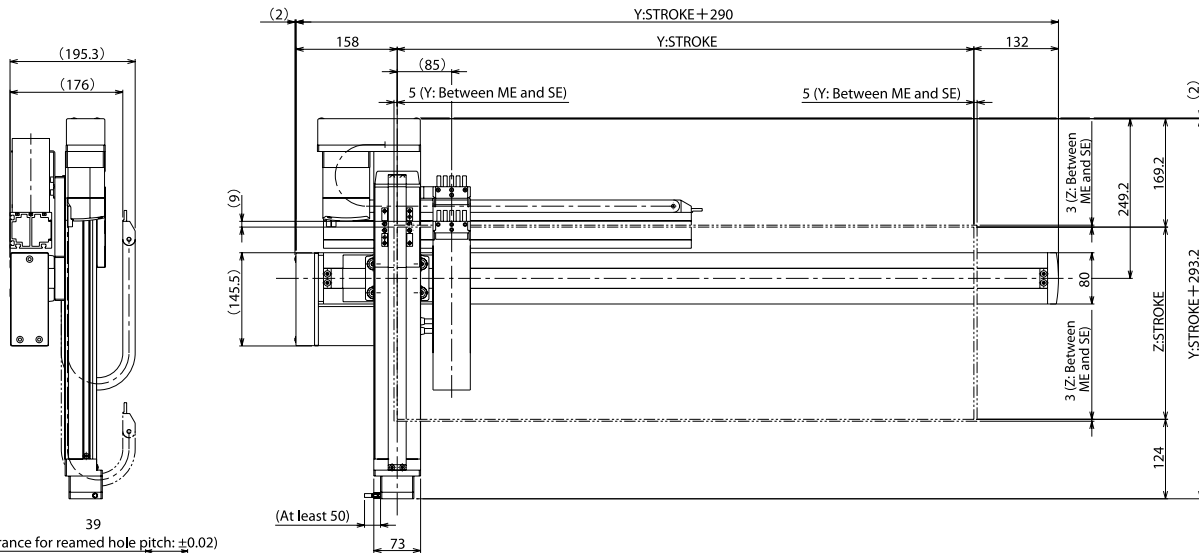
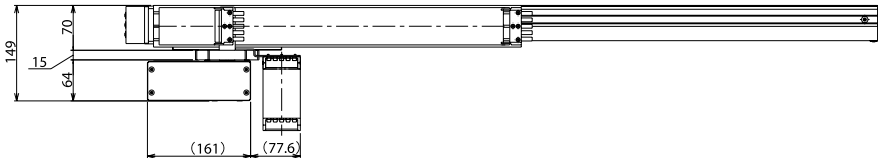

ME: Mechanical end  
SE: Stroke end

39  
(Tolerance for reamed hole pitch: ±0.02)

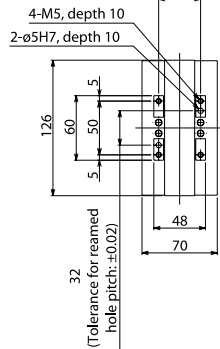

Detail view of Z-axis slider      Detail view of slot in bottom face of Y-axis base

Dimensions by Stroke

Y: Model	50	100	150	200	250	300	350	400	450	500	550	600	650	700	750	800	850	900	950	1000
B	50	100	150	200	250	300	350	400	450	500	550	600	650	700	750	800	850	900	950	1000
C	50	100	150	0	50	100	150	0	50	100	150	0	50	100	150	0	50	100	150	0
D	8	8	8	10	12	12	12	14	16	16	16	18	20	20	20	22	24	24	24	26
N	1	1	1	2	2	2	2	3	3	3	3	4	4	4	4	5	5	5	5	6
G	149	174	199	224	249	274	299	324	349	374	399	424	449	474	499	524	549	574	599	624

Controllers

Applicable controller

Refer to P. 91 for the controllers.

2-axis Combinations RCP2

2-axis Combinations RCS2

3-axis Combinations RCP2

3-axis Combinations RCS2

Controllers

# IK3-PBBG1□□S

RCP2 3-axis combination (XYB+Z-axis, base mount)

X axis: SS8R (Reversed, Single-slider)

Y axis: SA7R (Reversed) Z axis: SA6R (Reversed)

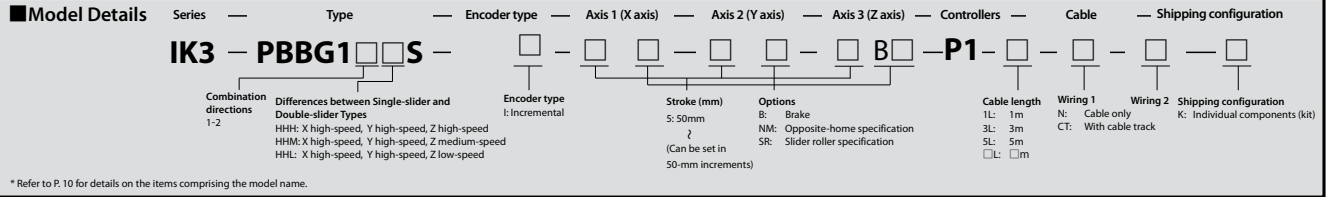

With cable tracks (Wiring 3 does not come with a cable track)

**Maximum Stroke**

X axis 1000 mm    Y axis 300 mm    Z axis 200 mm

**Maximum Speed**

	X high-speed, Y high-speed, Z high-speed	X high-speed, Y high-speed, Z medium-speed	X high-speed, Y high-speed, Z low-speed
X axis	220mm/s		
Y axis	420mm/s		
Z axis	500mm/s	250mm/s	125mm/s

**Maximum Load Capacity**

Y-axis stroke	X high-speed, Y high-speed, Z high-speed	X high-speed, Y high-speed, Z medium-speed	X high-speed, Y high-speed, Z low-speed
50mm	1.0kg	2.0kg	4.0kg
100mm			
150mm			
200mm			
250mm			
300mm			

**List by Stroke**

Y-axis stroke	Incremental											
	50				100				150			
Z-axis stroke	50	100	150	200	50	100	150	200	50	100	150	200
50	-	-	-	-	-	-	-	-	-	-	-	-
100	-	-	-	-	-	-	-	-	-	-	-	-
150	-	-	-	-	-	-	-	-	-	-	-	-
200	-	-	-	-	-	-	-	-	-	-	-	-
250	-	-	-	-	-	-	-	-	-	-	-	-
300	-	-	-	-	-	-	-	-	-	-	-	-
350	-	-	-	-	-	-	-	-	-	-	-	-
400	-	-	-	-	-	-	-	-	-	-	-	-
450	-	-	-	-	-	-	-	-	-	-	-	-
500	-	-	-	-	-	-	-	-	-	-	-	-
550	-	-	-	-	-	-	-	-	-	-	-	-
600	-	-	-	-	-	-	-	-	-	-	-	-
650	-	-	-	-	-	-	-	-	-	-	-	-
700	-	-	-	-	-	-	-	-	-	-	-	-
750	-	-	-	-	-	-	-	-	-	-	-	-
800	-	-	-	-	-	-	-	-	-	-	-	-
850	-	-	-	-	-	-	-	-	-	-	-	-
900	-	-	-	-	-	-	-	-	-	-	-	-
950	-	-	-	-	-	-	-	-	-	-	-	-
1000	-	-	-	-	-	-	-	-	-	-	-	-

Y-axis stroke	Incremental											
	200				250				300			
Z-axis stroke	50	100	150	200	50	100	150	200	50	100	150	200
50	-	-	-	-	-	-	-	-	-	-	-	-
100	-	-	-	-	-	-	-	-	-	-	-	-
150	-	-	-	-	-	-	-	-	-	-	-	-
200	-	-	-	-	-	-	-	-	-	-	-	-
250	-	-	-	-	-	-	-	-	-	-	-	-
300	-	-	-	-	-	-	-	-	-	-	-	-
350	-	-	-	-	-	-	-	-	-	-	-	-
400	-	-	-	-	-	-	-	-	-	-	-	-
450	-	-	-	-	-	-	-	-	-	-	-	-
500	-	-	-	-	-	-	-	-	-	-	-	-
550	-	-	-	-	-	-	-	-	-	-	-	-
600	-	-	-	-	-	-	-	-	-	-	-	-
650	-	-	-	-	-	-	-	-	-	-	-	-
700	-	-	-	-	-	-	-	-	-	-	-	-
750	-	-	-	-	-	-	-	-	-	-	-	-
800	-	-	-	-	-	-	-	-	-	-	-	-
850	-	-	-	-	-	-	-	-	-	-	-	-
900	-	-	-	-	-	-	-	-	-	-	-	-
950	-	-	-	-	-	-	-	-	-	-	-	-
1000	-	-	-	-	-	-	-	-	-	-	-	-

**Cable track**

X-axis stroke	Y-axis stroke	
	50-200	250-300
50-400	-	-
450-600	-	-
650-800	-	-
850-1000	-	-

Note) Both wiring 1 and wiring 2 should have a cable bear, or neither of the two should have a cable track. A cable track cannot be specified for one of the wirings.

**List by Cable Length**

Name	Option code
Opposite-home specification	NM
Slider roller specification	SR

**List by Cable Length**

Type	Cable code	Length
Standard type	1L	1m
	3L	3m
	5L	5m

\* Axis 1 comes with a standard cable, while axes 2 and 3 come with a robot cable.  
 \* Refer to P.90 for lengths other than those specified above.

**Specifications**

Item	X axis	Y axis	Z axis
Axis model	RCP2-SS8R	RCP2-SA7R	RCP2-SA6R
Stroke (Can be set in 50-mm increments)	50-1000mm	50-300mm	50-200mm
Axis 2	High-speed type: 220mm/s	High-speed type: 420mm/s	High-speed type: 500mm/s Medium-speed type: 250mm/s Low-speed type: 125mm/s
Motor size	56-square pulse motor	56-square pulse motor	42-square pulse motor
Ball screw lead	High-speed type: 20mm	High-speed type: 16mm	High-speed type: 12mm Medium-speed type: 6mm Low-speed type: 3mm
Drive method	Ball screw, $\phi$ 16mm, rolled, C10	Ball screw, $\phi$ 12mm, rolled, C10	Ball screw, $\phi$ 10mm, rolled, C10
Positioning repeatability	$\pm 0.02$ mm		
Base material	Dedicated alloy steel	Aluminum	
Surrounding air temperature/humidity	0 to 40°C, 85% RH or below (non-condensing)		

**Dimensions**

You can download CAD drawings from our website. [www.intelligentactuator.com](http://www.intelligentactuator.com)

Note 1. The connected position shown in the drawing defines the home.  
 Note 2. The drawing below assumes that both wiring 1 and wiring 2 have a cable track.  
 Note 3. For details on the cable track, refer to P. 90.

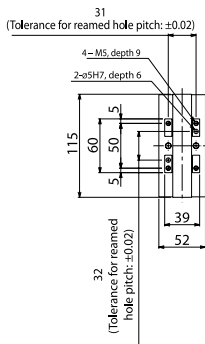
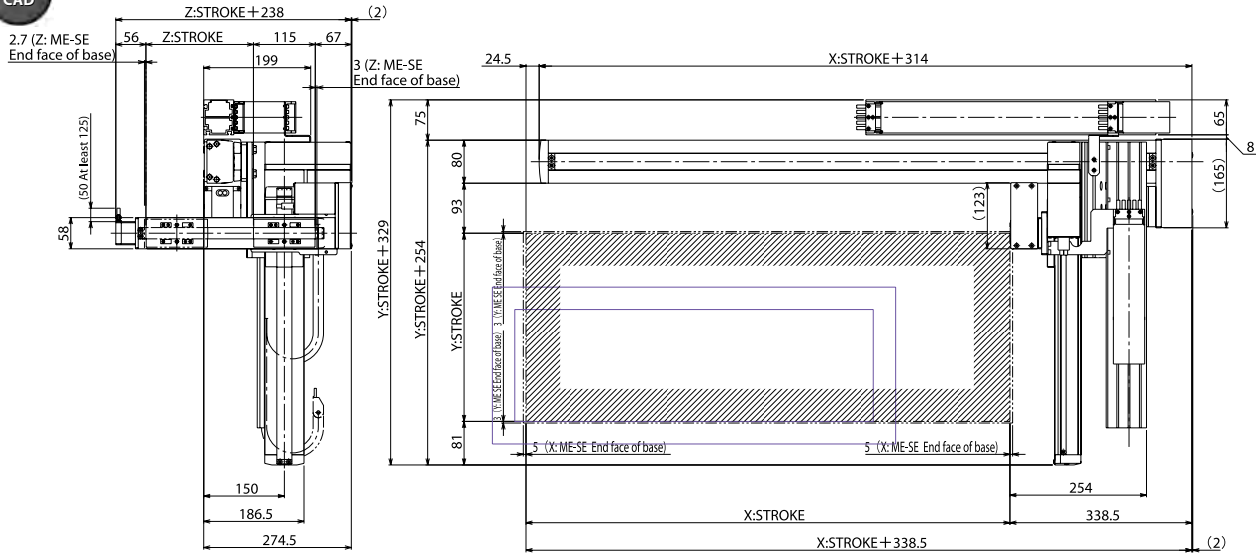

Detail view of Z-axis slider



Detail view of slot in bottom face of X-axis base

ME: Mechanical end  
 SE: Stroke end

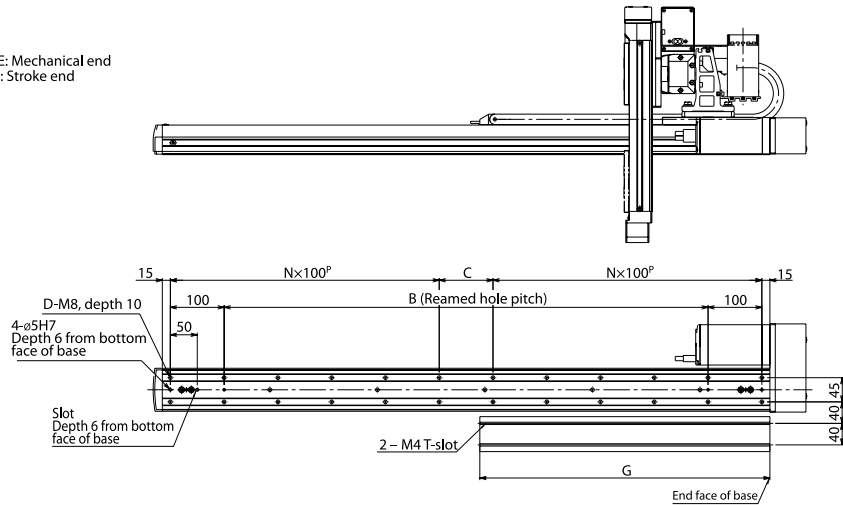

Detail view of X-axis installation

**Dimensions by Stroke**

X: Model	50	100	150	200	250	300	350	400	450	500	550	600	650	700	750	800	850	900	950	1000
B	50	100	150	200	250	300	350	400	450	500	550	600	650	700	750	800	850	900	950	1000
C	50	100	150	0	50	100	150	0	50	100	150	0	50	100	150	0	50	100	150	0
D	8	8	8	10	12	12	12	14	16	16	16	18	20	20	20	22	24	24	24	26
N	1	1	1	2	2	2	2	3	3	3	3	4	4	4	4	5	5	5	5	6
G	114.5	139.5	164.5	189.5	214.5	239.5	264.5	289.5	314.5	339.5	364.5	389.5	414.5	439.5	464.5	489.5	514.5	539.5	564.5	589.5

**Controllers**

Applicable controller



Refer to P. 91 for the controllers.

2-axis  
Combinations  
RCP 2

2-axis  
Combinations  
RCS 2

3-axis  
Combinations  
RCP 2

3-axis  
Combinations  
RCS 2

Controllers



# Controllers

<b>PSEL</b>	<b>RCP2-series program controller</b>	<b>PSEL-C</b>	<b>93</b>
<b>SSEL</b>	<b>RCS2-series program controller</b>	<b>SSEL-C</b>	<b>103</b>
<b>XSEL</b>	<b>RCS2-series multi-axis program controller</b>	<b>X-SEL-J / K / P / Q</b>	<b>125</b>

Model  
List

PSEL

SSEL

ROBONET

XSEL

# List of Applicable Controllers

	IA kit model	Applicable controller	
2-axis	IK2-PXBD IK2-PXBC	PSEL-C-2-42PI-42PI-NP-2-0	2-axis controller
		PCON-C-42PI-NP-2-0	1-axis controller
		RPCON-42P	1 unit
	IK2-PXBB IK2-PXZB IK2-PYBB	PSEL-C-2-56PI-56PI-NP-2-0	2-axis controller
		PCON-C-56PI-NP-2-0	1-axis controller
		RPCON-56P	1 unit
	IK2-SXBD	SSEL-C-2-60I-20I-NP-2-[1]	2-axis controller (incremental)
		SSEL-C-2-60A-20A-NP-2-[1]	2-axis controller (absolute)
		SCON-C-60I-NP-2-[1]	1-axis controller (incremental for X-axis)
		SCON-C-60A-NP-2-[1]	1-axis controller (absolute for X-axis)
		SCON-C-20I-NP-2-[1]	1-axis controller (incremental for Y-axis)
		SCON-C-20A-NP-2-[1]	1-axis controller (absolute for Y-axis)
	IK2-SXBC	SSEL-C-2-60I-30I-NP-2-[1]	2-axis controller (incremental)
		SSEL-C-2-60A-30A-NP-2-[1]	2-axis controller (absolute)
		SCON-C-60I-NP-2-[1]	1-axis controller (incremental for X-axis)
		SCON-C-60A-NP-2-[1]	1-axis controller (absolute for X-axis)
		SCON-C-30I-NP-2-[1]	1-axis controller (incremental for Y-axis)
		SCON-C-30A-NP-2-[1]	1-axis controller (absolute for Y-axis)
	IK2-SXBB	SSEL-C-2-100I-60I-NP-2-[1]	2-axis controller (incremental)
		SSEL-C-2-100A-60A-NP-2-[1]	2-axis controller (absolute)
		SCON-C-100I-NP-2-[1]	1-axis controller (incremental for X-axis)
		SCON-C-100A-NP-2-[1]	1-axis controller (absolute for X-axis)
		SCON-C-60I-NP-2-[1]	1-axis controller (incremental for Y-axis)
		SCON-C-60A-NP-2-[1]	1-axis controller (absolute for Y-axis)
	IK2-SXBA	SSEL-C-2-150I-100I-NP-2-[1]	2-axis controller (incremental)
		SSEL-C-2-150A-100A-NP-2-[1]	2-axis controller (absolute)
		SCON-C-150I-NP-2-[1]	1-axis controller (incremental for X-axis)
		SCON-C-150A-NP-2-[1]	1-axis controller (absolute for X-axis)
		SCON-C-100I-NP-2-[1]	1-axis controller (incremental for Y-axis)
		SCON-C-100A-NP-2-[1]	1-axis controller (absolute for Y-axis)
	IK2-SXZB	SSEL-C-2-100I-60I-NP-2-[1]	2-axis controller (incremental)
		SSEL-C-2-100A-60A-NP-2-[1]	2-axis controller (absolute)
		SCON-C-100I-NP-2-[1]	1-axis controller (incremental for X-axis)
		SCON-C-100A-NP-2-[1]	1-axis controller (absolute for X-axis)
		SCON-C-60I-NP-2-[1]	1-axis controller (incremental for Z-axis)
		SCON-C-60A-NP-2-[1]	1-axis controller (absolute for Z-axis)
IK2-SYBB	SSEL-C-2-100I-60I-NP-2-[1]	2-axis controller (incremental)	
	SSEL-C-2-100A-60A-NP-2-[1]	2-axis controller (absolute)	
	SCON-C-100I-NP-2-[1]	1-axis controller (incremental for Y-axis)	
	SCON-C-100A-NP-2-[1]	1-axis controller (absolute for Y-axis)	
	SCON-C-60I-NP-2-[1]	1-axis controller (incremental for Z-axis)	
	SCON-C-60A-NP-2-[1]	1-axis controller (absolute for Z-axis)	
3-axis	IK3-PBBG	PSEL-C-2-56PI-42PI-NP-2-0	2-axis controller (for X/Y-axes)
		PCON-C-56PI-NP-2-0	1-axis controller (for X-axis)
		PCON-C-42PI-NP-2-0	1-axis controller (for Y-axis, Z-axis)
		RPCON-56P	1-axis controller (for X-axis)
		RPCON-42P	1-axis controller (for Y-axis, Z-axis)
	IK3-SBBG	SSEL-C-2-100I-60I-NP-2-[1]	2-axis controller (incremental for X/Y-axis)
		SSEL-C-2-100A-60A-NP-2-[1]	2-axis controller (absolute for X/Y-axis)
		SCON-C-100I-NP-2-[1]	1-axis controller (incremental for X-axis)
		SCON-C-100A-NP-2-[1]	1-axis controller (absolute for X-axis)
		SCON-C-60I-NP-2-[1]	1-axis controller (incremental for Y-axis)
		SCON-C-60A-NP-2-[1]	1-axis controller (absolute for Y-axis)
		SCON-C-30I-NP-2-[1]	1-axis controller (incremental for Z-axis)
		SCON-C-30A-NP-2-[1]	1-axis controller (absolute for Z-axis)
		XSEL-J/K/P/Q	Multi-axis controller (incremental or absolute for X/Y/Z-axis)

[1] Power-supply voltage (1: Single-phase 100 VAC / 2: Single-phase 200 VAC)

2-axis Combinations R C P 2  
 2-axis Combinations R C S 2  
 3-axis Combinations R C P 2  
 3-axis Combinations R C S 2  
 Controllers  
 Model List  
 PSEL  
 SSEL  
 ROBOTNET  
 XSEL



# PSEL



RCP2-series  
program controller

## Model List

A program controller capable of operating RCP2-series actuators. Various controls can be performed with a single unit.

Type	C	
Name	Program mode	Positioner mode
Exterior view		
Description	This controller can operate actuators and communicate with external devices without requiring any additional device. If two axes are operated, arc interpolation and path operation can be performed.	Up to 1,500 positioning points are supported. Push-motion operation and teaching operation are also possible.
Number of positions	1,500	

## Model

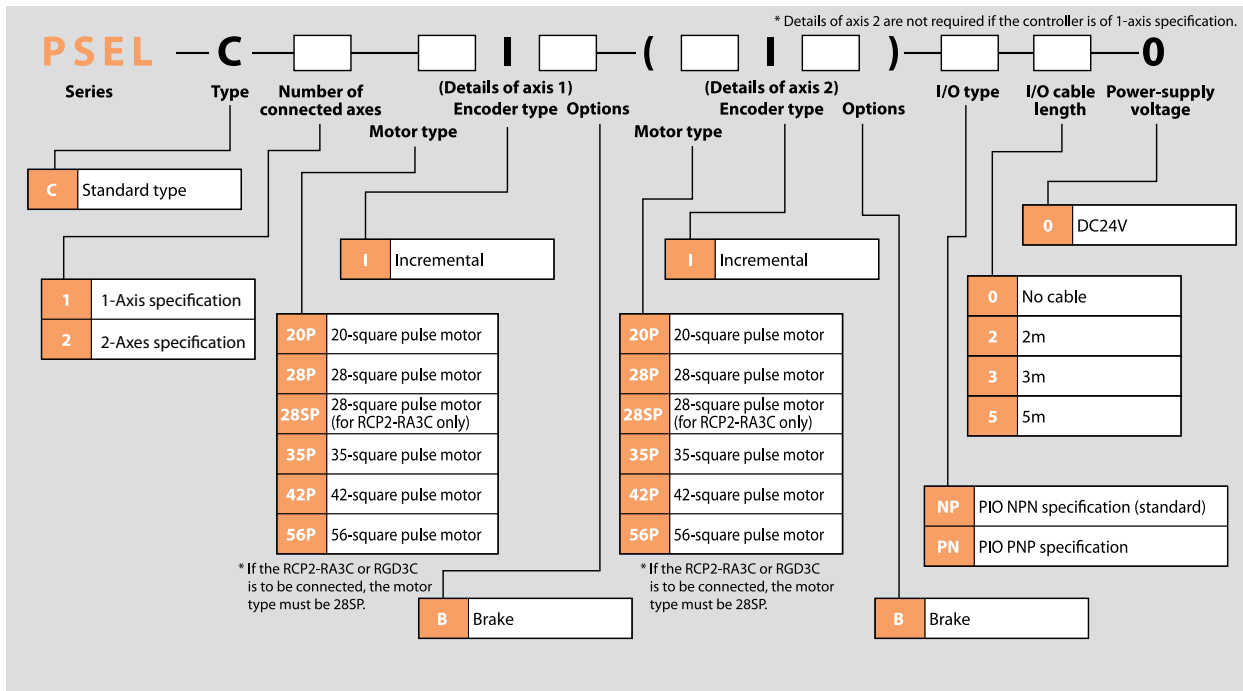

## I/O Specifications

### Input External input specifications

Item	Specification
Input voltage	DC24V ±10%
Input current	7 mA per circuit
ON/OFF voltages	ON voltage (min.) NPN: DC16V/ PNP: DC8V OFF voltage (max.) NPN: DC5V/ PNP: DC19V
Insulation method	Photo-coupler

#### NPN specification

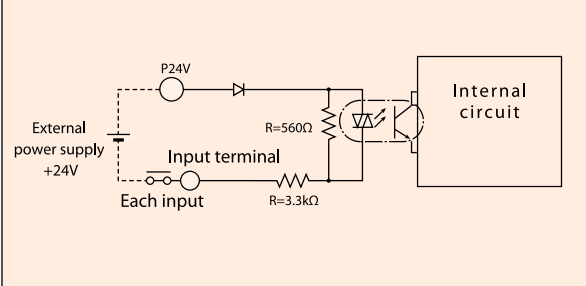

#### PNP specification

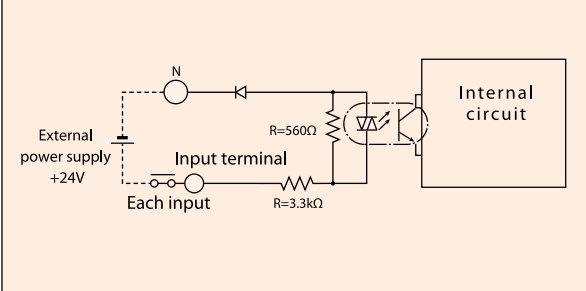

### Output External output specifications

Item	Specification
Load voltage	DC24V
Maximum load current	100 mA per point, total 400 mA for 8 points
Leak current (max.)	Max. 0.1 mA per point
Insulation method	Photo-coupler

#### NPN specification

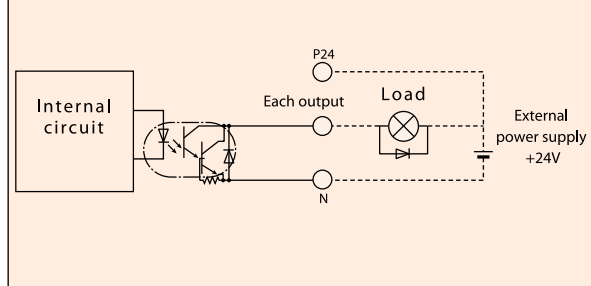

#### PNP specification

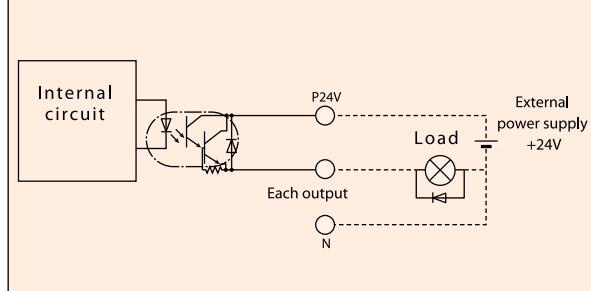

## Explanation of I/O Functions

The PSEL controller can be operated in the “Program Mode” where a program is entered to operate the actuator or “Positioner Mode” where the actuator is moved to positions specified by signals received from a host PLC.

The positioner mode includes the following five input patterns to support various applications.

### Functions by Controller Type

Operation mode		Features
Program mode		You can use Super SEL, a language that allows for complex controls using simple commands, to perform linear and smooth interpolation operations, path operation ideal for coating and other applications, arch motion and palletizing operations, and more.
Product-type Switchover Mode	Standard mode	The basic operation mode where all you need is to specify a position number and enter a start signal. Push-motion operation, and linear interpolation operation of two axes, is also supported.
	Type switching mode	When the system handles multiple loads of the same shape but slightly different hole positions, you can issue movement commands to the same position number by changing the type number.
	2-axis independent mode	When a 2-axis controller is used, the two axes can be operated independently using separate commands.
	Teaching mode	The slider (rod) can be moved using an external signal to register the stopped position as position data.
	DS-S-C1 compatible mode	If you have been using a DS-S-C1 controller, you can swap it with a PSEL controller without having to change the host programs. * Compatibility with actuators is not assured.

**System Configuration**

- 2-axis Combinations RCP2
- 2-axis Combinations RCS2
- 3-axis Combinations RCP2
- 3-axis Combinations RCS2
- Controllers
- Model List
- PSEL
- SSEL
- ROBONET
- XSEL

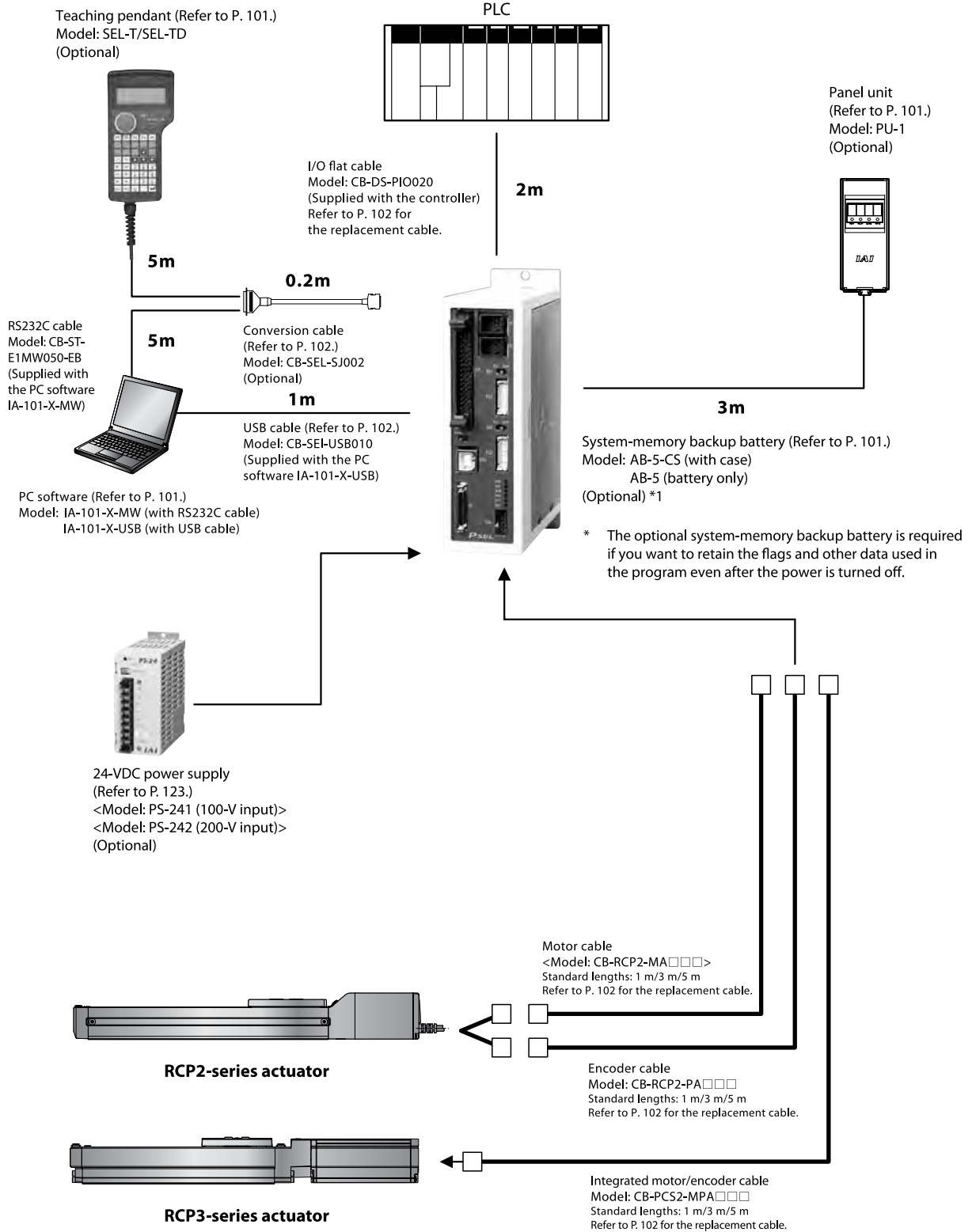

## Explanation of I/O Functions

### Program Mode

Pin No.	Category	Port No.	Program Mode	Function	Wiring diagram		
1A	P24	016	24-V input	Connect 24V.			
1B			Program No. 1 selection	Select the program number of the program you want to start. (Enter one of ports 016 to 022 by a BCD code.)			
2A			017			Program No. 2 selection	
2B			018			Program No. 4 selection	
3A			019			Program No. 8 selection	
3B			020			Program No. 10 selection	
4A			021			Program No. 20 selection	
4B			022			Program No. 40 selection	
5A			023	CPU reset		The system is reset and enters the same state achieved after the power has been reconnected.	
5B			000	Start		The program selected by one of port Nos. 016 to 022 is started.	
6A			Input	001		General-purpose input	The system waits for an external input in response to a program command.
6B				002		General-purpose input	
7A				003		General-purpose input	
7B				004		General-purpose input	
8A				005		General-purpose input	
8B				006		General-purpose input	
9A				007		General-purpose input	
9B	008	General-purpose input					
10A	009	General-purpose input					
10B	010	General-purpose input					
11A	011	General-purpose input					
11B	012	General-purpose input					
12A	013	General-purpose input					
12B	014	General-purpose input					
13A	Output	015	General-purpose input	These signals can be turned ON/OFF freely using program commands.			
13B		300	Alarm		This signal is output when an alarm has occurred. (Contact B)		
14A		301	Ready		This signal is output when the controller has started properly and become ready to operate.		
14B		302	General-purpose output				
15A		303	General-purpose output				
15B		304	General-purpose output				
16A		305	General-purpose output				
16B	306	General-purpose output					
17A	307	General-purpose output					
17B	N		OV input	Connect OV.			

### Positioner, Standard Mode

Pin No.	Category	Port No.	Standard Positioner Mode	Function	Wiring diagram		
1A	P24	016	24-V input	Connect 24V.			
1B			Position input 10	Use one of port Nos. 007 to 019 to specify the position number corresponding to the position to move the actuator to. The value can be specified by either a BCD or binary code.			
2A			017			Position input 11	
2B			018			Position input 12	
3A			019			Position input 13	
3B			020			-	
4A			021			-	
4B			022			-	
5A			023	Error reset		This signal resets minor errors. (The power must be reconnected to reset major errors.)	
5B			000	Start		The actuator starts moving to the position corresponding to the selected position number.	
6A			Input	001		Home return	The actuator returns home.
6B				002		Servo ON	The servo is turned ON/OFF.
7A				003		Push motion	The actuator performs push-motion operation.
7B				004		Pause	The actuator pauses when this signal turns OFF, and resumes the remaining operation when the signal turns ON.
8A				005		Cancel	The actuator stops when this signal turns OFF, and the remaining operation is cancelled.
8B				006		Interpolation setting	In the case of a 2-axis specification, the actuators move via linear interpolation while this signal is ON.
9A				007		Position input 1	Use one of port Nos. 007 to 019 to specify the position number corresponding to the position to move the actuator to. The value can be specified by either a BCD or binary code.
9B	008	Position input 2					
10A	009	Position input 3					
10B	010	Position input 4					
11A	011	Position input 5					
11B	012	Position input 6					
12A	013	Position input 7					
12B	014	Position input 8					
13A	Output	015	Position input 9	These signals are output when the specified operation has completed.			
13B		300	Alarm		This signal is output when an alarm has occurred. (Contact B)		
14A		301	Ready		This signal is output when the controller has started properly and become ready to operate.		
14B		302	Positioning complete		This signal is output when movement to the specified position has completed.		
15A		303	Home return complete		This signal is output when home return has completed.		
15B		304	Servo ON output		This signal is output while the servo is ON.		
16A		305	Push-motion complete		This signal is output when push-motion operation has completed.		
16B	306	System battery error	This signal is output when the system battery voltage has dropped (to the warning level).				
17A	307	-	-				
17B	N		OV input	Connect OV.			

2-axis Combinations RCP2

2-axis Combinations RCS2

3-axis Combinations RCP2

3-axis Combinations RCS2

Controllers

Model List

PSEL

SSEL

ROBONET

XSEL

Explanation of I/O Functions

Positioner, Product-Type Switchover Mode

Pin No.	Category	Port No.	Type-switching Positioner Mode	Function			
1A	P24	016	24-V input	Connect 24V.			
1B			Position/type input 10	Use one of port Nos. 007 to 022 to specify the position number corresponding to the position to move the actuator to, and another to specify the type number. Assignment of position numbers and type numbers are set using parameters. The value can be specified by either a BCD or binary code.			
2A			Position/type input 11				
2B			Position/type input 12				
3A			Position/type input 13				
3B			Position/type input 14				
4A			Position/type input 15				
4B			Position/type input 16				
5A			023		Error reset	This signal resets minor errors. (The power must be reconnected to reset major errors.)	
5B			000		Start	The actuator starts moving to the position corresponding to the selected position number.	
6A			001		Home return	The actuator returns home.	
6B			002	Servo ON	The servo is turned ON/OFF.		
7A			Input	003	Push motion	The actuator performs push-motion operation.	
7B					004	Pause	The actuator pauses when this signal turns OFF, and resumes the remaining operation when the signal turns ON.
8A					005	Cancel	The actuator stops when this signal turns OFF, and the remaining operation is cancelled.
8B					006	Interpolation setting	In the case of a 2-axis specification, the actuators move via linear interpolation while this signal is ON.
9A	007	Position/type input 1			Use one of port Nos. 007 to 022 to specify the position number corresponding to the position to move the actuator to, and another to specify the type number. Assignment of position numbers and type numbers are set using parameters. The value can be specified by either a BCD or binary code.		
9B	008	Position/type input 2					
10A	009	Position/type input 3					
10B	010	Position/type input 4					
11A	011	Position/type input 5					
11B	012	Position/type input 6					
12A	013	Position/type input 7					
12B	014	Position/type input 8					
13A	015	Position/type input 9					
13B	Output	300	Alarm	This signal is output when an alarm has occurred. (Contact B)			
14A			301	Ready	This signal is output when the controller has started properly and become ready to operate.		
14B			302	Positioning complete	This signal is output when movement to the specified position has completed.		
15A			303	Home return complete	This signal is output when home return has completed.		
15B			304	Servo ON output	This signal is output while the servo is ON.		
16A			305	Push-motion complete	This signal is output when push-motion operation has completed.		
16B			306	System battery error	This signal is output when the system battery voltage has dropped (to the warning level).		
17A			307	-	-		
17B	N	OV input	OV input	Connect OV.			

Wiring diagram

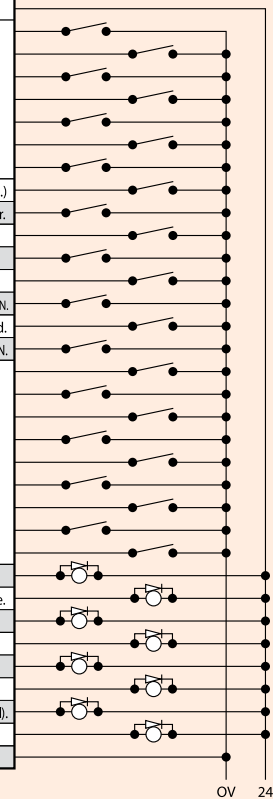

Positioner, 2-axes Independent Mode

Pin No.	Category	Port No.	Type-switching Positioner Mode	Function			
1A	P24	016	24-V input	Connect 24V.			
1B			Position input 7	Use any of port Nos. 010 to 022 to specify the position number corresponding to the position to move the actuator to. Assignment of position numbers for axes 1 and 2 are set using parameters. The value can be specified by either a BCD or binary code.			
2A			Position input 8				
2B			Position input 9				
3A			Position input 10				
3B			Position input 11				
4A			Position input 12				
4B			Position input 13				
5A			023		Error reset	This signal resets minor errors. (The power must be reconnected to reset major errors.)	
5B			000		Start 1	Axis 1 starts moving to the selected position number.	
6A			001		Home return 1	Axis 1 returns home.	
6B			002	Servo ON 1	The servo of axis 1 is turned ON/OFF.		
7A			Input	003	Pause 1	Axis 1 pauses when this signal turns OFF, and resumes the remaining operation when the signal turns ON.	
7B					004	Cancel 1	Movement of axis 1 is cancelled.
8A					005	Start 2	Axis 2 starts moving to the selected position number.
8B					006	Home return 2	Axis 2 returns home.
9A	007	Servo ON 2			The servo of axis 2 is turned ON/OFF.		
9B	008	Pause 2			Axis 2 pauses when this signal turns OFF, and resumes the remaining operation when the signal turns ON.		
10A	009	Cancel 2			Movement of axis 2 is cancelled.		
10B	010	Position input 1			Use any of port Nos. 010 to 022 to specify the position number corresponding to the position to move the actuator to. Assignment of position numbers for axes 1 and 2 are set using parameters. The value can be specified by either a BCD or binary code.		
11A	011	Position input 2					
11B	012	Position input 3					
12A	013	Position input 4					
12B	014	Position input 5					
13A	015	Position input 6					
13B	Output	300	Alarm	This signal is output when an alarm has occurred. (Contact B)			
14A			301	Ready		This signal is output when the controller has started properly and become ready to operate.	
14B			302	Positioning complete 1		This signal is output when movement of axis 1 to the specified position has completed.	
15A			303	Home return complete 1	This signal is output when home return of axis 1 has completed.		
15B			304	Servo ON output 1	This signal is output while the servo of axis 1 is ON.		
16A			305	Positioning complete 2	This signal is output when movement of axis 2 to the specified position has completed.		
16B			306	Home return complete 2	This signal is output when home return of axis 2 has completed.		
17A			307	Servo ON output 2	This signal is output while the servo of axis 2 is ON.		
17B	N	OV input	OV input	Connect OV.			

Wiring diagram

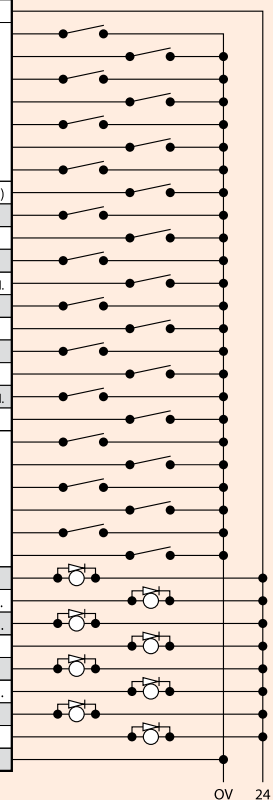

- 2-axis Combinations RCP2
- 2-axis Combinations RCS2
- 3-axis Combinations RCP2
- 3-axis Combinations RCS2
- Controllers

- Model List
- PSEL
- SEEL
- ROBONET
- XSEL

Explanation of I/O Functions

Positioner, Teach Mode

Pin No.	Category	Port No.	Type-switching Positioner Mode	Function	Wiring diagram		
1A	P24	016	24-V input	Connect 24V.			
1B			Axis 1 JOG -	Axis 1 moves in the negative direction while this signal is input.			
2A			Axis 2 JOG +	Axis 2 moves in the positive direction while this signal is input.			
2B			Axis 2 JOG -	Axis 2 moves in the negative direction while this signal is input.			
3A			019	Inching specification (0.01 mm)		Specify the travel over which to move the actuator by inching. (The travel is the sum of values specified by port Nos. 019 to 022.)	
3B			020	Inching specification (0.1 mm)			
4A			021	Inching specification (0.5 mm)			
4B			022	Inching specification (1 mm)			
5A			023	Error reset		This signal resets minor errors. (The power must be reconnected to reset major errors.)	
5B			000	Start		The actuator starts moving to the position corresponding to the selected position number.	
6A			001	Servo ON		The servo is turned ON/OFF.	
6B			002	Pause		The actuator pauses when this signal turns OFF, and resumes the remaining operation when the signal turns ON.	
7A			Input	003		Position input 1	Use one of port Nos. 003 to 013 to specify the position number corresponding to the position to move the actuator to, and another to specify the position number under which to input the current position. If port No. 014 for teaching mode specification is ON, the current value is written to the specified position number when port No. 000 for start signal turns ON.
7B				004		Position input 2	
8A				005		Position input 3	
8B				006		Position input 4	
9A				007		Position input 5	
9B	008	Position input 6					
10A	009	Position input 7					
10B	010	Position input 8					
11A	011	Position input 9					
11B	012	Position input 10					
12A	013	Position input 11					
12B	014	Teaching mode specification					
13A	015	Axis 1 JOG +	Axis 1 moves in the positive direction while this signal is input.				
13B	300	Alarm	This signal is output when an alarm has occurred. (Contact B)				
14A	301	Ready	This signal is output when the controller has started properly and become ready to operate.				
14B	302	Positioning complete	This signal is output when movement to the specified position has completed.				
15A	303	Home return complete	This signal is output when home return has completed.				
15B	304	Servo ON output	This signal is output while the servo is ON.				
16A	305	-	-				
16B	306	System battery error	This signal is output when the system battery voltage has dropped (to the warning level).				
17A	307	-	-				
17B	N	OV input	Connect OV.				

Positioner, DS-S-C1 Compatible Mode

Pin No.	Category	Port No.	Standard Positioner Mode	Function	Wiring diagram		
1A	P24	016	24-V input	Connect 24V.			
1B			Position No. 1000	(Same with port Nos. 004 to 015.)			
2A			017	-			
2B			018	-			
3A			019	-			
3B			020	-			
4A			021	-			
4B			022	-			
5A			023	CPU reset		The system is reset and enters the same state achieved after the power has been reconnected.	
5B			000	Start		The actuator starts moving to the position corresponding to the selected position number.	
6A			001	Hold (pause)		The actuator pauses when this signal turns ON, and resumes the remaining operation when the signal turns OFF.	
6B			002	Cancel		The actuator stops when this signal turns ON, and the remaining operation is cancelled.	
7A			Input	003		Interpolation setting	In the case of a 2-axis specification, the actuators move via linear interpolation while this signal is ON. Use one of port Nos. 004 to 016 to specify the position number corresponding to the position to move the actuator to. The value is specified by a BCD code.
7B				004		Position No. 1	
8A				005		Position No. 2	
8B				006		Position No. 4	
9A				007		Position No. 8	
9B	008	Position No. 10					
10A	009	Position No. 20					
10B	010	Position No. 40					
11A	011	Position No. 80					
11B	012	Position No. 100					
12A	013	Position No. 200					
12B	014	Position No. 400					
13A	015	Position No. 800					
13B	300	Alarm	This signal is output when an alarm has occurred. (Contact A)				
14A	301	Ready	This signal is output when the controller has started properly and become ready to operate.				
14B	302	Positioning complete	This signal is output when movement to the specified position has completed.				
15A	303	-	-				
15B	304	-	-				
16A	305	-	-				
16B	306	System battery error	This signal is output when the system battery voltage has dropped (to the warning level).				
17A	307	-	-				
17B	N	OV input	Connect OV.				

2-axis Combinations R C P 2

2-axis Combinations R C S 2

3-axis Combinations R C P 2

3-axis Combinations R C S 2

Controllers

Model List

PSEL

SSEL

ROBONET

XSEL

**Specification Table**

	Item	Specification
Base specifications	Connected actuator	RCP2-series actuator (Note 1)
	Input voltage	24 VDC ±10%
	Power-supply capacity	Max. 5.5 A
	Dielectric strength	500 VDC, 10 MΩ or more
	Withstand voltage	500 VAC, 1 minute
	Rush current	Max. 30 A
	Vibration resistance	XYZ directions: 10 to 57 Hz: (Single amplitude) 0.035 mm (continuous), 0.0 75 mm (intermittent) 58 to 150 Hz: 4.9 m/sec <sup>2</sup> (continuous), 9.8 m/sec <sup>2</sup> (intermittent)
Control specifications	Number of controlled axes	1/2
	Maximum total output of connected axes	-
	Position detection method	Incremental encoder
	Speed setting	1 mm/sec ~ (The maximum limit varies depending on the actuator.)
	Acceleration setting	0.01 G ~ (The maximum limit varies depending on the actuator.)
	Operation method	Program operation/positioner operation (switchable)
Program	Program language	Super SEL
	Number of programs	64
	Number of program steps	2,000
	Number of multi-tasking programs	8
	Number of positioning points	1500
	Data storage device	Flash ROM (An optional system-memory backup battery can be added.)
Communication related	Data input method	Teaching pendant or PC software
	Number of I/O points	24 input points/8 output points (NPN/PNP selectable)
	I/O power supply	24 VDC ±10%, externally supplied
	PIO cable	CB-DS-PIO□□□ (supplied with the controller)
	Serial communication function	RS232C (half-pitch connector)/USB connector
	Field network cable	(To be supported in the future)
	Motor cable	CB-RCP2-MA□□□ (max. 20 m)
	Encoder cable	CB-RCP2-PA□□□ (max. 20 m)
General specifications	Protective functions	Motor/driver temperature check, encoder open check, soft limit overtravel, system error, battery error, etc.
	Surrounding air temperature/humidity	0 to 40°C, 10 to 95% (non-condensing)
	Surrounding ambience	Free from corrosive gases or significant dust.
	Protection degree	IP20
	Weight	Approx. 450 g
External dimensions		43 mm (W) x 159 mm (H) x 110 mm (D)

The high-thrust type (RA10C), high-speed type (HS8C/HS8R) and waterproof type (RCP2W-SA16) are not operated.

**External Dimensions**

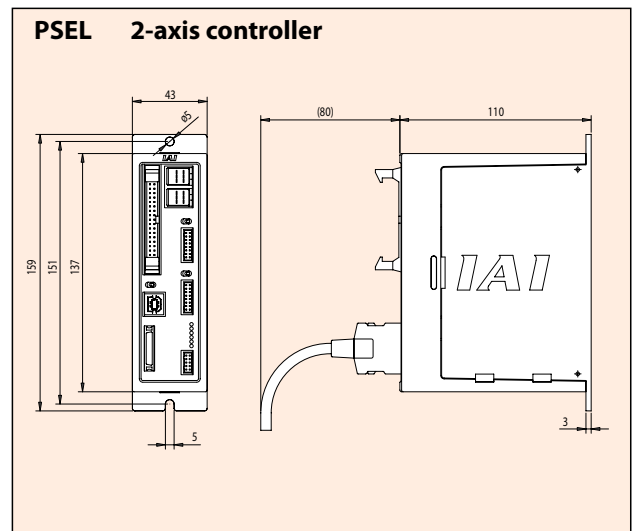
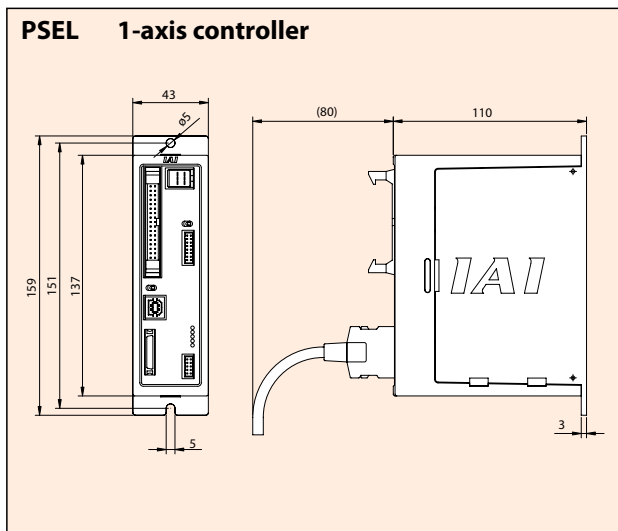



Name of Each part

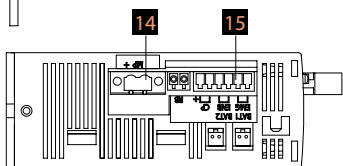
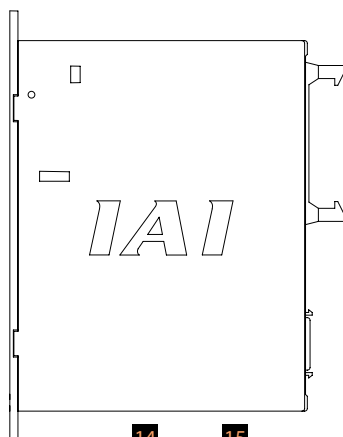
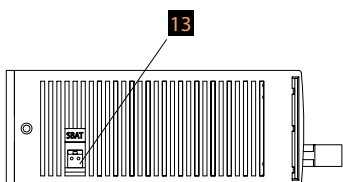
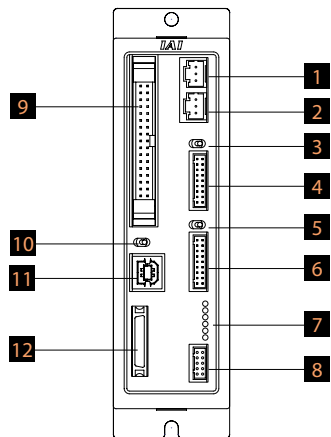

**1** Axis 1 motor connector

Connect the motor cable for actuator axis 1 here.

**2** Axis 2 motor connector

Connect the motor cable for actuator axis 2 here.

**3** Axis 1 brake switch

This switch is used to release the axis brake. When the switch is set to the left (RLS) position, the brake is forcibly released. When the switch is set to the right (NOM) position, the brake is controlled automatically by the controller.

**4** Axis 1 encoder connector

Connect the encoder cable for actuator axis 1 here.

**5** Axis 2 brake switch

This switch is used to release the axis brake. When the switch is set to the left (RLS) position, the brake is forcibly released. When the switch is set to the right (NOM) position, the brake is controlled automatically by the controller.

**6** Axis 2 encoder connector

Connect the encoder cable for actuator axis 2 here.

**7** Status indicator LEDs

These LEDs indicate the operating status of the controller. What is indicated by each LED is explained below:

**PWR:** The power is currently input to the controller.

**RDY:** The controller is ready to perform program operation.

**ALM:** The controller is abnormal.

**EMG:** An emergency stop has been actuated and the drive source is being cut off.

**SV1:** The servo of actuator axis 1 is turned ON.

**SV2:** The servo of actuator axis 2 is turned ON.

**8** Panel unit connector

This connector is used to connect the panel unit (optional) for displaying the controller status and error numbers.

**9** IO connector

A connector for interface I/Os.

If a DIO (24IN/8OUT) interface is used, this connector accepts a 34-pin flat cable connector.

The IO power is also supplied to the controller through this connector (pins 1 and 34).

**10** Mode switch

This switch is used to indicate the operation mode of the controller.

The left position indicates the MANU (manual operation) mode, while the right position indicates the AUTO (auto operation) mode. Teaching operation can only be performed in the MANU mode, and operation using external I/Os cannot be performed in the MANU mode.

**11** USB connector

This connector is used to make USB connection with a PC. When the USB connector is in use, the TP connector cannot be used because communication through the TP connector is cut off.

**12** Teaching pendant connector

This half-pitch, IO26-pin connector is used to connect a teaching pendant when the operation mode is MANU. You need a dedicated conversion cable to connect to a conventional D-sub, 25-pin connector.

**13** System-memory backup battery connector

This connector is used to connect the battery needed to retain the various data stored in the built-in SRAM of the controller even after the power is cut off. The system-memory backup battery is installed on the exterior of the unit. This battery is not a standard accessory (available as an option).

**14** Motor-power input connector

This connector is used to input the motor power and consists of a 2-pin, 2-piece connector by Phoenix Contact.

**15** Control-power/system input connector

This connector is used to connect the controller power input, emergency stop switch and enable switch, and consists of a 6-pin, 2-piece connector by Phoenix Contact.

2-axis Combinations RCP2

2-axis Combinations RCS2

3-axis Combinations RCP2

3-axis Combinations RCS2

Controllers

Model List

PSEL

SSEL

ROBONET

XSEL



**Options**

**Teaching Pendant**

**Features** A teaching device offering functions for program/position input, test operation, monitoring, and more.

**Model/Price**

Model	Description
SEL-T-J	Standard type with connector conversion cable
SEL-TD-J	Deadman switch type with connector conversion cable

**Configuration**

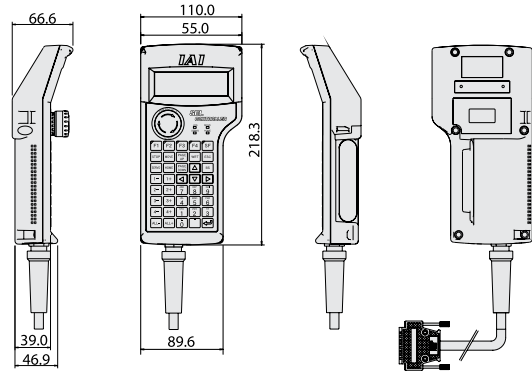
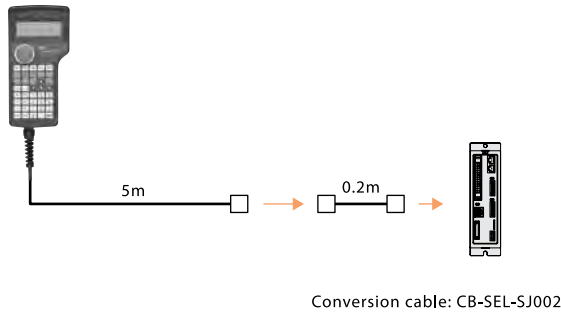

**Specification**

Item	SEL-T-J	SEL-TD-J
3-position enable switch	Not equipped	Equipped
ANSI/UL standard	Not compliant	Compliant
CE mark	Compliant	
Display	20 characters x 4 lines	
Surrounding air temperature/humidity	0-40°C 10-90%RH (non-condensing)	
Protection structure	IP54	
Weight	Approx. 0.4 kg (excluding cables)	

**PC Software (Windows only)**

**Features** A software program that assists the initial startup of your system, offering functions for program/position input, test operation, monitoring, and more. The enhanced debugging functions help reduce the startup time.

**Model** **IA-101-X-MW-J** (with RS232C cable + connector conversion cable)

**Configuration**

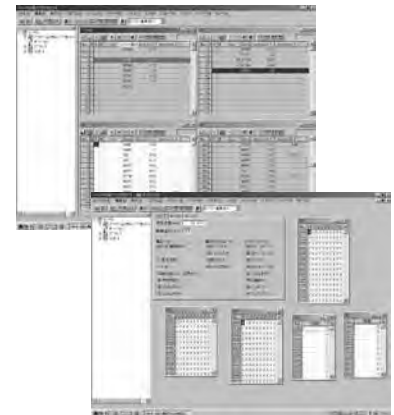
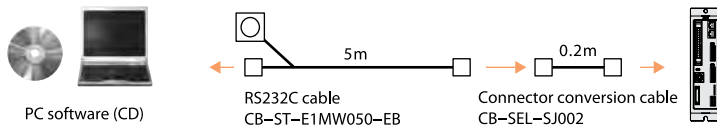

**Note**  
The PSEL controller only supports version 7.0.0.0 or later.

**Model** **IA-101-X-USB** (with USB cable)

**Configuration**

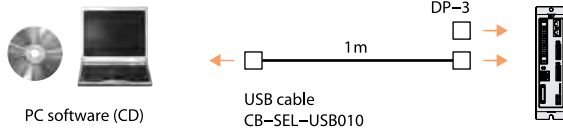

**Panel Unit**

**Features** A display for checking controller error codes and the program number of the current program.

**Model** **PU-1** (cable length: 3 m)

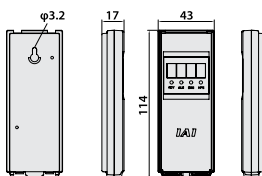

**System memory backup battery**

**Features** This battery is needed when global flags, etc., are used in the program and you want the data to be retained even after the power is turned off.

**Model** **AB-5-CS** (with case)  
**AB-5** (battery)



**Dummy plug**

**Features** This plug is connected to the teaching pendant to cut off the enable circuit when connecting the PSEL controller to a PC via a USB cable. (This plug is supplied with the PC software IA-101-X-USB.)

**Model** **DP-3**



Options

USB cable

**Features** This cable is used to connect a controller with USB port to a PC.  
To connect a controller without USB port (XSEL) to a PC, connect the controller's RS232C cable to a USB cable via a USB conversion adapter and connect the USB cable to the USB port on the PC.  
(Refer to the PC software IA-101-X-USBMW.)

**Model** **CB-SEL-USB010** (cable length: 1 m)



Connector conversion cable

**Features** This conversion cable is used to connect the D-sub, 25-pin connector for teaching pendant or PC to the teaching connector (half-pitch) on the PSEL controller.

**Model** **CB-SEL-SJ002** (cable length: 0.2 m)



Replacement Parts

If you must order a replacement cable, etc., after the initial purchase of your product, specify the correct model by referring to the information below.

Motor Cable

Item **CB-RCP2-MA** [ ] [ ] [ ] \* The standard motor cable is a robot cable.

\* [ ] [ ] [ ] indicates the cable length (L). A desired length up to 20 m can be specified. Example) 080 = 8 m

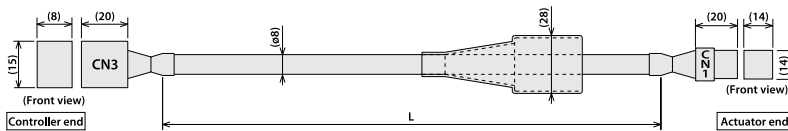

CN3			M cable			CN1			
Orange	A	A1	1	A	Yellow	1	A	Yellow	SLP-06V (JST)
Gray	VMM	A2	2	VMM	Gray	2	A	Gray	
White	B	A3	3	A	Orange	3	A	Orange	
Yellow	A	B1	4	B	Orange/Black	4	B	Orange/Black	
Pink	VMM	B2	5	VMM	Pink	5	B	Pink	
Orange/Black	B	B3	6	B	White	6	B	White	

Encoder Cable/Robot Encoder Cable

Item **CB-RCP2-PB** [ ] [ ] [ ] / **CB-RCP2-PB** [ ] [ ] [ ] -**RB** \* The standard encoder cable is a normal cable. A robot cable can be specified as an option.

\* [ ] [ ] [ ] indicates the cable length (L). A desired length up to 20 m can be specified. Example) 080 = 8 m

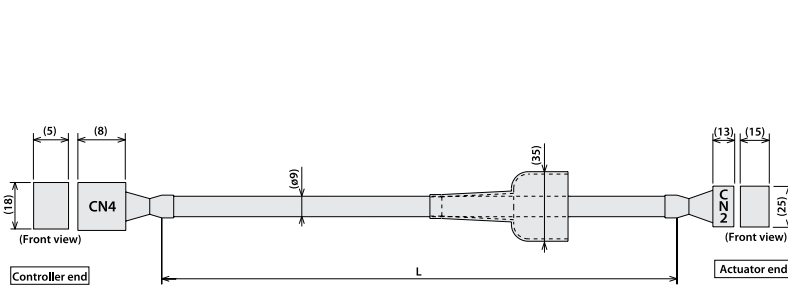

CN4			Signal name			Pin name			CN2		
Blue (red 1)	LS+	16	LS+	16	1	ENA	Brown	Lightgray/Black	1	ENA	Lightgray/Black
White	LS-	15	LS-	15	2	ENA	Green	Lightgray/Black	2	ENA	Lightgray/Black
Red	BK+	14	BK+	14	3	ENB	Purple	White/Black	3	ENB	White/Black
Gray	ENB	13	ENB	13	4	ENB	Pink	White/Black	4	ENB	White/Black
Brown	LS+	12	LS+	12	5	LS+	Orange	Pink/Black	5	LS+	Pink/Black
Green	ENB	11	ENB	11	6	LS+	Yellow	White/Black	6	LS+	White/Black
Purple	ENB	10	ENB	10	7	VPS	Yellow	White/Black	7	VPS	White/Black
Pink	ENB	9	ENB	9	8	VPS	Orange	Pink/Black	8	VPS	Pink/Black
White	ENB	8	ENB	8	9	GND	Blue	Pink/Black	9	GND	Pink/Black
Yellow	VPS	7	VPS	7	10	VBB	Blue	Pink/Black	10	VBB	Pink/Black
Orange	VBB	6	VBB	6	11	VPS	Yellow	White/Black	11	VPS	White/Black
Blue	NC	4	NC	4	12	LS+	Blue (red 1)	Orange/Black	12	LS+	Orange/Black
NC	NC	3	NC	3	13	LS+	Blue (red 1)	Orange/Black	13	LS+	Orange/Black
NC	NC	2	NC	2	14	LS-	White	Orange/red 2	14	LS-	White
Ground	FG	1	FG	1	15	BK+	Red	Orange/Black	15	BK+	Red
					16	BK-	Gray	Orange/red 1	16	BK-	Gray
					17	BK-	Gray	Orange/red 1	17	BK-	Gray
					18	F.G	Ground	Ground	18	F.G	Ground

Integrated Motor/Encoder Cable for RCP3

Item **CB-PCS-MPA** [ ] [ ] [ ]

\* [ ] [ ] [ ] indicates the cable length (L). A desired length up to 10 m can be specified. Example) 080 = 8 m

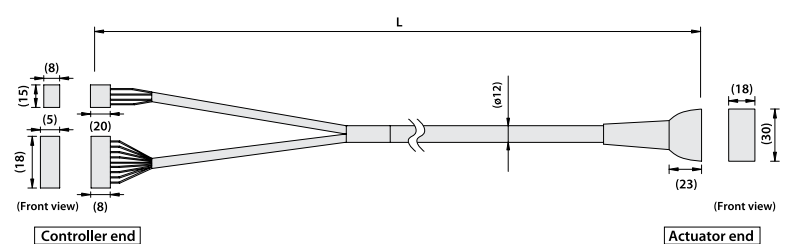

Signal	Pin No.	(Wire color)	Pin No.	Signal
A	B1	Black	B1	VMM
VMM	A2	White	A2	A
/A	A1	Red	B2	B
B	B3	Green	B3	VMM
B	B3	Yellow	B3	/B
VMM	B2	Brown	A4	NC
/B	A3		B4	NC
BK+	14	Pink (Red.)	A5	BK+
BK-	13	Pink (Blue.)	B5	BK-
LS+	16	White (Red.)	A6	LS+
LS-	15	White (Blue.)	B6	LS-
A+	12	Orange (Red.)	A7	A+
A-	11	Orange (Blue.)	B7	A-
B+	10	Gray (Red.)	A8	B+
B-	9	Gray (Blue.)	B8	B-
NC	8		A9	NC
VPS	7	Orange (Blue continuous)	B9	VPS
VCC	6	Gray (Red continuous)	A10	VCC
GND	5	Gray (Blue continuous)	B10	GND
NC	4		A11	NC
FG	1	Shield	B11	FG

I/O Flat Cable

Item **CB-DS-PIO** [ ] [ ] [ ]

\* [ ] [ ] [ ] indicates the cable length (L). A desired length up to 10 m can be specified. Example) 080 = 8 m

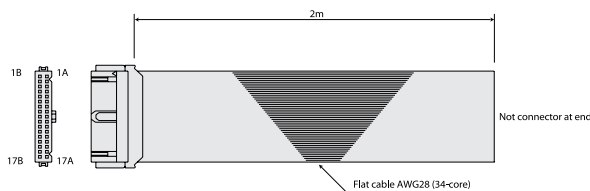

No.	Color	Wire	No.	Color	Wire
1A	Brown 1		9B	Gray 2	
1B	Red 1		10A	White 2	
2A	Orange 1		10B	Black 2	
2B	Yellow 1		11A	Brown-3	
3A	Green 1		11B	Red 3	
3B	Blue 1		12A	Orange 3	
4A	Purple 1		12B	Yellow 3	
4B	Gray 1		13A	Green 3	
5A	White 1		13B	Blue 3	
5B	Black 1	pressure-welded	14A	Purple 3	pressure-welded
6A	Brown-2		14B	Gray 3	
6B	Red 2		15A	White 3	
7A	Orange 2		15B	Black 3	
7B	Yellow 2		16A	Brown-4	
8A	Green 2		16B	Red 4	
8B	Blue 2		17A	Orange 4	
9A	Purple 2		17B	Yellow 4	

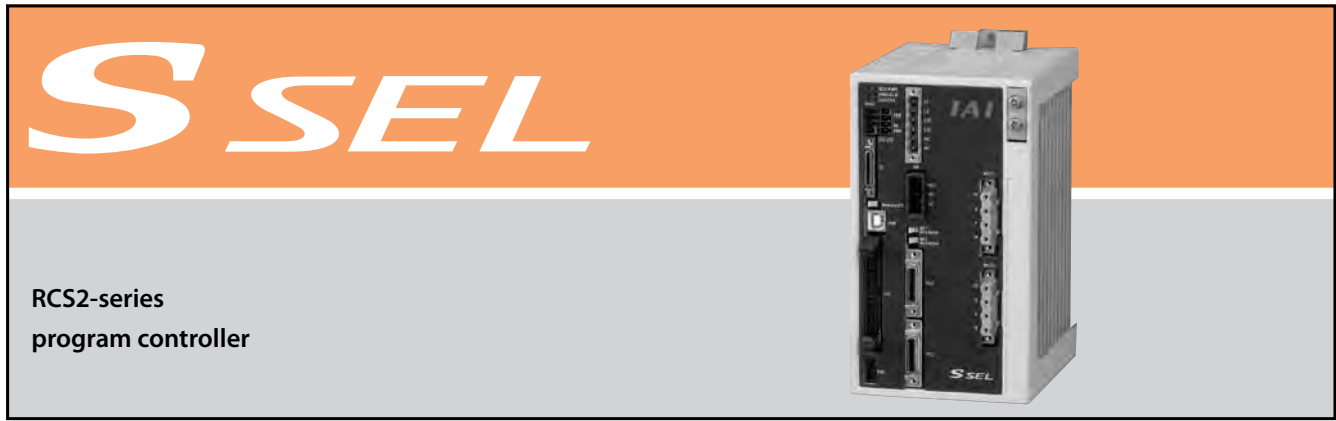

RCS2-series program controller

**Model List/Pricing**

A program controller capable of operating RCS2-series actuators. Various controls can be performed with a single unit.

Type	C	
Name	Program mode	Positioner mode
Exterior view		
Description	This controller can operate actuators and communicate with external devices without requiring any additional device. If two axes are operated, arc interpolation, path operation and synchronized operation can be performed.	Up to 20,000 positioning points are supported. Push-motion operation and teaching operation are also possible.
Number of positions	20,000	

**Model**

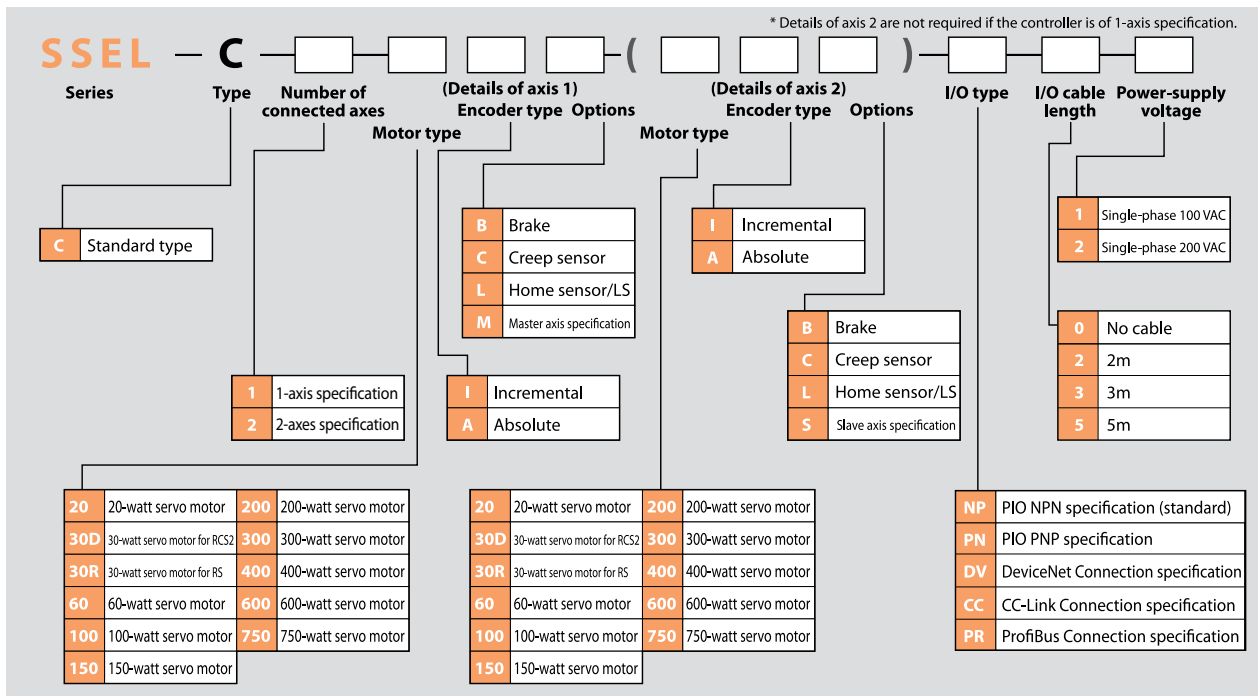

System Configuration

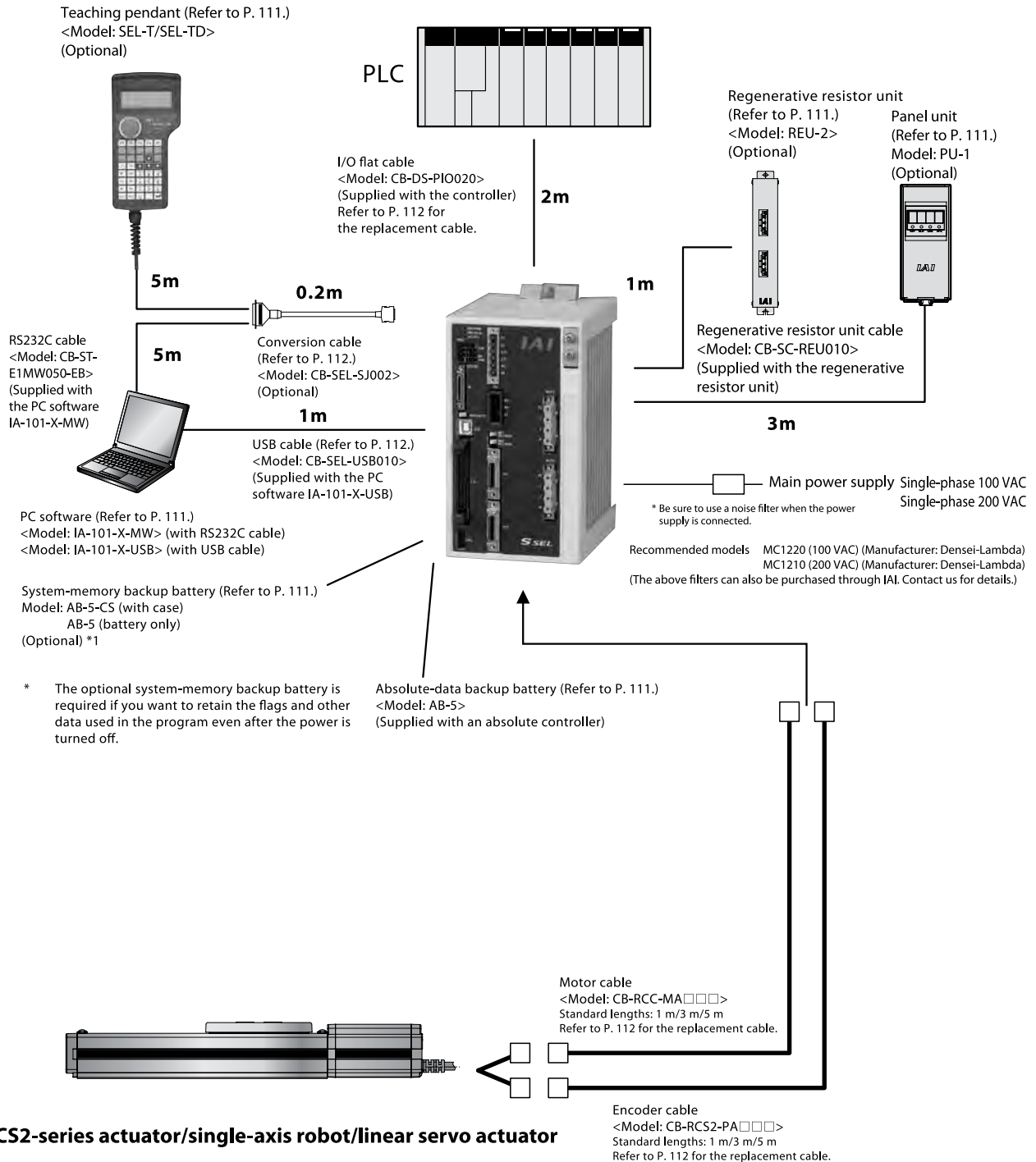

2-axis  
Combinations  
R C P 2

2-axis  
Combinations  
R C S 2

3-axis  
Combinations  
R C P 2

3-axis  
Combinations  
R C S 2

Controllers

Model  
List

PSEL

SSEL

ROBONET

XSEL

I/O Specifications

Input External input specifications

Item	Specification
Input voltage	DC24V ±10%
Input current	7 mA per circuit
ON/OFF voltages	ON voltage (min.) NPN: DC16V/ PNP: DC8V OFF voltage (max.) NPN: DC5V/ PNP: DC19V
Insulation method	Photo-coupler

NPN specification

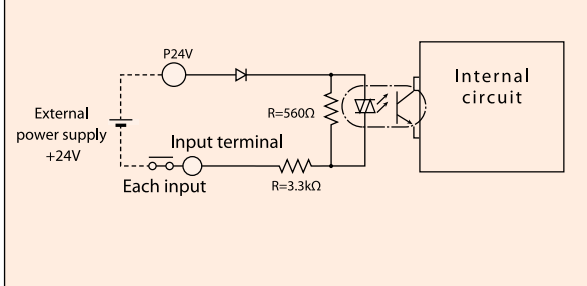

PNP specification

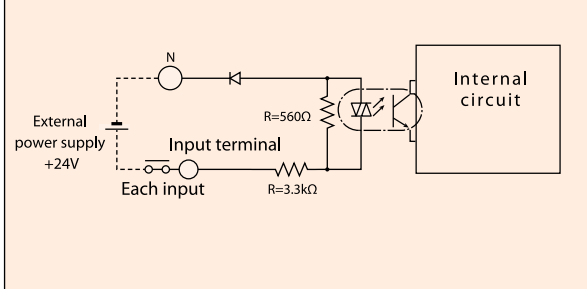

Output External output specifications

Item	Specification
Load voltage	DC24V
Maximum load current	100 mA per point, total 400 mA for 8 points
Leak current (max.)	Max. 0.1 mA per point
Insulation method	Photo-coupler

NPN specification

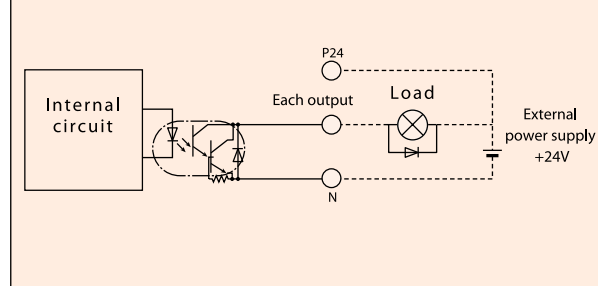

PNP specification

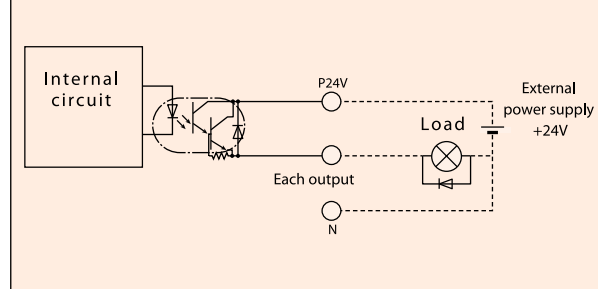

Explanation of I/O Functions

The SSEL controller can be operated in the “Program Mode” where a program is entered to operate the actuator or “Positioner Mode” where the actuator is moved to positions specified by signals received from a host PLC.

The positioner mode includes the following five input patterns to support various applications.

Functions by Controller Type

Operation mode	Features	
Program mode	You can use Super SEL, a language that allows for complex controls using simple commands, to perform linear and smooth interpolation operations, path operation ideal for coating and other applications, arch motion and palletizing operations, and more.	
Product-Type Switchover Mode	Standard mode	The basic operation mode where all you need is to specify a position number and enter a start signal. Push-motion operation, and linear interpolation operation of two axes, is also supported.
	Type switching mode	When the system handles multiple loads of the same shape but slightly different hole positions, you can issue movement commands to the same position number by changing the type number.
	2-axis independent mode	When a 2-axis controller is used, the two axes can be operated independently using separate commands.
	Teaching mode	The slider (rod) can be moved using an external signal to register the stopped position as position data.
	DS-S-C1 compatible mode	If you have been using a DS-S-C1 controller, you can swap it with a PSEL controller without having to change the host programs. * Compatibility with actuators is not assured.

Explanation of I/O Functions

Program Mode

Pin No.	Category	Port No.	Program Mode	Function	Wiring diagram	
1A	P24		24-V input	Connect 24 V.		
1B		016	Program No. 1 selection	Select the program number of the program you want to start. (Enter one of ports 016 to 022 by a BCD code.)		
2A		017	Program No. 2 selection			
2B		018	Program No. 4 selection			
3A		019	Program No. 8 selection			
3B		020	Program No. 10 selection			
4A		021	Program No. 20 selection			
4B		022	Program No. 40 selection			
5A		023	CPU reset	The system is reset and enters the same state achieved after the power has been reconnected.		
5B		000	Start	The program selected by one of port Nos. 016 to 022 is started.		
6A		Input	001	General-purpose input		The system waits for an external input in response to a program command.
6B			002	General-purpose input		
7A			003	General-purpose input		
7B			004	General-purpose input		
8A			005	General-purpose input		
8B			006	General-purpose input		
9A			007	General-purpose input		
9B	008		General-purpose input			
10A	009		General-purpose input			
10B	010		General-purpose input			
11A	011		General-purpose input			
11B	012		General-purpose input			
12A	013		General-purpose input			
12B	014	General-purpose input				
13A	Output	015	General-purpose input	These signals can be turned ON/OFF freely using program commands.		
13B		300	Alarm		This signal is output when an alarm has occurred. (Contact B)	
14A		301	Ready		This signal is output when the controller has started properly and become ready to operate.	
14B		302	General-purpose output			
15A		303	General-purpose output			
15B		304	General-purpose output			
16A		305	General-purpose output			
16B	306	General-purpose output				
17A	307	General-purpose output				
17B	N		OV input	Connect OV.		

Positioner, Standard Mode

Pin No.	Category	Port No.	Standard Positioner Mode	Function	Wiring diagram	
1A	P24		24-V input	Connect 24 V.		
1B		016	Position input 10	Use one of port Nos. 007 to 019 to specify the position number corresponding to the position to move the actuator to. The value can be specified by either a BCD or binary code.		
2A		017	Position input 11			
2B		018	Position input 12			
3A		019	Position input 13			
3B		020	Position input 14			
4A		021	Position input 15			
4B		022	Position input 16			
5A		023	Error reset	This signal resets minor errors. (The power must be reconnected to reset major errors.)		
5B		000	Start	The actuator starts moving to the position corresponding to the selected position number.		
6A		Input	001	Home return		The actuator returns home.
6B			002	Servo ON		The servo is turned ON/OFF.
7A			003	Push motion		The actuator performs push-motion operation.
7B			004	Pause		The actuator pauses when this signal turns OFF, and resumes the remaining operation when the signal turns ON.
8A			005	Cancel		The actuator stops when this signal turns OFF, and the remaining operation is cancelled.
8B			006	Interpolation setting		In the case of a 2-axis specification, the actuators move via linear interpolation while this signal is ON.
9A			007	Position input 1		Use one of port Nos. 007 to 019 to specify the position number corresponding to the position to move the actuator to. The value can be specified by either a BCD or binary code.
9B	008		Position input 2			
10A	009		Position input 3			
10B	010		Position input 4			
11A	011		Position input 5			
11B	012		Position input 6			
12A	013		Position input 7			
12B	014	Position input 8				
13A	Output	015	Position input 9	These signals are output when the specified operation is completed.		
13B		300	Alarm		This signal is output when an alarm has occurred. (Contact B)	
14A		301	Ready		This signal is output when the controller has started properly and become ready to operate.	
14B		302	Positioning complete		This signal is output when movement to the specified position has completed.	
15A		303	Home return complete		This signal is output when home return has completed.	
15B		304	Servo ON output		This signal is output while the servo is ON.	
16A		305	Push-motion complete		This signal is output when push-motion operation has completed.	
16B	306	System battery error	This signal is output when the system battery voltage has dropped (to the warning level).			
17A	307	Absolute battery error	This signal is output when the absolute battery voltage has dropped (to the warning level).			
17B	N		OV input	Connect OV.		

Explanation of I/O Functions

Positioner, Product-Type Switchover Mode

Pin No.	Category	Port No.	Type-switching Positioner Mode	Function	
1A	P24		24-V input	Connect 24 V.	
1B		016	Position/type input 10	Use one of port Nos. 007 to 022 to specify the position number corresponding to the position to move the actuator to, and another to specify the type number. Assignment of position numbers and type numbers are set using parameters. The value can be specified by either a BCD or binary code.	
2A		017	Position/type input 11		
2B		018	Position/type input 12		
3A		019	Position/type input 13		
3B		020	Position/type input 14		
4A		021	Position/type input 15		
4B		022	Position/type input 16		
5A		023	Error reset		This signal resets minor errors. (The power must be reconnected to reset major errors.)
5B		000	Start		The actuator starts moving to the position corresponding to the selected position number.
6A		001	Home return	The actuator returns home.	
6B		002	Servo ON	The servo is turned ON/OFF.	
7A	Input	003	Push motion	The actuator performs push-motion operation.	
7B		004	Pause	The actuator pauses when this signal turns OFF, and resumes the remaining operation when the signal turns ON.	
8A		005	Cancel	The actuator stops when this signal turns OFF, and the remaining operation is cancelled.	
8B		006	Interpolation setting	In the case of a 2-axis specification, the actuators move via linear interpolation while this signal is ON.	
9A		007	Position/type input 1	Use one of port Nos. 007 to 022 to specify the position number corresponding to the position to move the actuator to, and another to specify the type number. Assignment of position numbers and type numbers are set using parameters. The value can be specified by either a BCD or binary code.	
9B		008	Position/type input 2		
10A		009	Position/type input 3		
10B		010	Position/type input 4		
11A		011	Position/type input 5		
11B	012	Position/type input 6			
12A	013	Position/type input 7			
12B	014	Position/type input 8			
13A	015	Position/type input 9			
13B	Output	300	Alarm	This signal is output when an alarm has occurred. (Contact B)	
14A		301	Ready	This signal is output when the controller has started properly and become ready to operate.	
14B		302	Positioning complete	This signal is output when movement to the specified position has completed.	
15A		303	Home return complete	This signal is output when home return has completed.	
15B		304	Servo ON output	This signal is output while the servo is ON.	
16A		305	Push-motion complete	This signal is output when push-motion operation has completed.	
16B		306	System battery error	This signal is output when the system battery voltage has dropped (to the warning level).	
17A		307	Absolute battery error	This signal is output when the absolute battery voltage has dropped (to the warning level).	
17B		N		OV input	Connect OV.

Wiring diagram

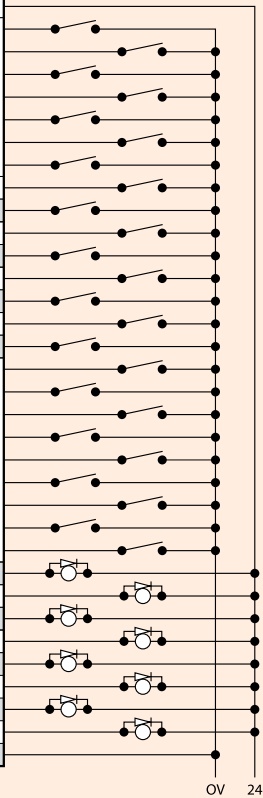

Positioner, 2-axes Independent Mode

Pin No.	Category	Port No.	Type-switching Positioner Mode	Function	
1A	P24		24-V input	Connect 24 V.	
1B		016	Position input 7	Use any of port Nos. 010 to 022 to specify the position number corresponding to the position to move the actuator to. Assignment of position numbers for axes 1 and 2 are set using parameters. The value can be specified by either a BCD or binary code.	
2A		017	Position input 8		
2B		018	Position input 9		
3A		019	Position input 10		
3B		020	Position input 11		
4A		021	Position input 12		
4B		022	Position input 13		
5A		023	Error reset		This signal resets minor errors. (The power must be reconnected to reset major errors.)
5B		000	Start 1		Axis 1 starts moving to the selected position number.
6A		001	Home return 1	Axis 1 returns home.	
6B		002	Servo ON 1	The servo of axis 1 is turned ON/OFF.	
7A	Input	003	Pause 1	Axis 1 pauses when this signal turns OFF, and resumes the remaining operation when the signal turns ON.	
7B		004	Cancel 1	Movement of axis 1 is cancelled.	
8A		005	Start 2	Axis 2 starts moving to the selected position number.	
8B		006	Home return 2	Axis 2 returns home.	
9A		007	Servo ON 2	The servo of axis 2 is turned ON/OFF.	
9B		008	Pause 2	Axis 2 pauses when this signal turns OFF, and resumes the remaining operation when the signal turns ON.	
10A		009	Cancel 2	Movement of axis 2 is cancelled.	
10B		010	Position input 1	Use any of port Nos. 010 to 022 to specify the position number corresponding to the position to move the actuator to. Assignment of position numbers for axes 1 and 2 are set using parameters. The value can be specified by either a BCD or binary code.	
11A		011	Position input 2		
11B	012	Position input 3			
12A	013	Position input 4			
12B	014	Position input 5			
13A	015	Position input 6			
13B	Output	300	Alarm		This signal is output when an alarm has occurred. (Contact B)
14A		301	Ready		This signal is output when the controller has started properly and become ready to operate.
14B		302	Positioning complete 1		This signal is output when movement of axis 1 to the specified position has completed.
15A		303	Home return complete 1	This signal is output when home return of axis 1 has completed.	
15B		304	Servo ON output 1	This signal is output while the servo of axis 1 is ON.	
16A		305	Positioning complete 2	This signal is output when movement of axis 2 to the specified position has completed.	
16B		306	Home return complete 2	This signal is output when home return of axis 2 has completed.	
17A		307	Servo ON output 2	This signal is output while the servo of axis 2 is ON.	
17B		N		OV input	Connect OV.

Wiring diagram

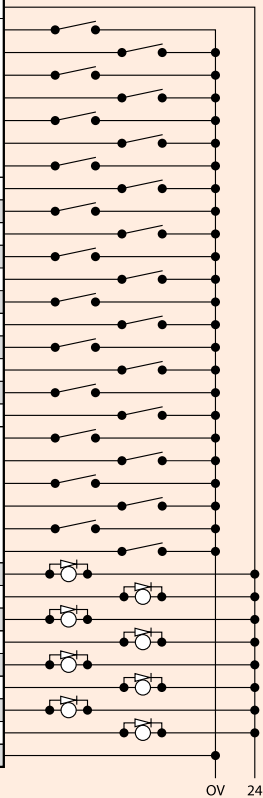



Explanation of I/O Functions

Positioner, Teaching Mode

Pin No.	Category	Port No.	Type-switching Positioner Mode	Function	Wiring diagram			
1A	P24	016	24-V input	Connect 24V.				
1B			Axis 1 JOG -	Axis 1 moves in the negative direction while this signal is input.				
2A			017	Axis 2 JOG +		Axis 2 moves in the positive direction while this signal is input.		
2B			018	Axis 2 JOG -		Axis 2 moves in the negative direction while this signal is input.		
3A			019	Inching specification (0.01 mm)		Specify the travel over which to move the actuator by inching. (The travel is the sum of values specified by port Nos. 019 to 022.)		
3B			020	Inching specification (0.1 mm)				
4A			021	Inching specification (0.5 mm)				
4B			022	Inching specification (1 mm)				
5A			023	Error reset			This signal resets minor errors. (The power must be reconnected to reset major errors.)	
5B			000	Start		The actuator starts moving to the position corresponding to the selected position number.		
6A			001	Servo ON		The servo is turned ON/OFF.		
6B			002	Pause		The actuator pauses when this signal turns OFF, and resumes the remaining operation when the signal turns ON.		
7A			Input	003		Position input 1	Use one of port Nos. 003 to 013 to specify the position number corresponding to the position to move the actuator to, and another to specify the position number under which to input the current position. If port No. 14 for teaching mode specification is ON, the current value is written to the specified position number when port No. 000 for start signal turns ON.	
7B						004		Position input 2
8A						005		Position input 3
8B						006		Position input 4
9A						007		Position input 5
9B	008	Position input 6						
10A	009	Position input 7						
10B	010	Position input 8						
11A	011	Position input 9						
11B	012	Position input 10						
12A	013	Position input 11						
12B	014	Teaching mode specification						
13A	Output	300	Axis 1 JOG +	Axis 1 moves in the positive direction while this signal is input.				
13B			Alarm	This signal is output when an alarm has occurred. (Contact B)				
14A			301	Ready	This signal is output when the controller has started properly and become ready to operate.			
14B			302	Positioning complete	This signal is output when movement to the specified position has completed.			
15A			303	Home return complete	This signal is output when home return has completed.			
15B			304	Servo ON output	This signal is output while the servo is ON.			
16A			305	-	-			
16B	306	System battery error	This signal is output when the system battery voltage has dropped (to the warning level).					
17A	N	307	Absolute battery error	This signal is output when the absolute battery voltage has dropped (to the warning level).				
17B			OV input	Connect OV.				

Positioner, DS-S-C1 Compatible Mode

Pin No.	Category	Port No.	Standard Positioner Mode	Function	Wiring diagram			
1A	P24	016	24-V input	Connect 24V.				
1B			Position No. 1000	(Same with port Nos. 004 to 015.)				
2A			017	Position No. 2000		-		
2B			018	Position No. 4000		-		
3A			019	Position No. 8000		-		
3B			020	Position No. 10000		-		
4A			021	Position No. 20000		-		
4B			022	NC (*1)		-		
5A			023	CPU reset		The system is reset and enters the same state achieved after the power has been reconnected.		
5B			000	Start		The actuator starts moving to the position corresponding to the selected position number.		
6A			001	Hold (pause)		The actuator pauses when this signal turns ON, and resumes the remaining operation when the signal turns OFF.		
6B			002	Cancel		The actuator stops when this signal turns ON, and the remaining operation is cancelled.		
7A			Input	003		Interpolation setting	In the case of a 2-axis specification, the actuators move via linear interpolation while this signal is ON. Use one of port Nos. 004 to 016 to specify the position number corresponding to the position to move the actuator to. The value is specified by a BCD code.	
7B						004		Position No. 1
8A						005		Position No. 2
8B						006		Position No. 4
9A						007		Position No. 8
9B	008	Position No. 10						
10A	009	Position No. 20						
10B	010	Position No. 40						
11A	011	Position No. 80						
11B	012	Position No. 100						
12A	013	Position No. 200						
12B	014	Position No. 400						
13A	015	Position No. 800						
13B	Output	300	Alarm	This signal is output when an alarm has occurred. (Contact A)				
14A			301	Ready	This signal is output when the controller has started properly and become ready to operate.			
14B			302	Positioning complete	This signal is output when movement to the specified position has completed.			
15A			303	-	-			
15B			304	-	-			
16A			305	-	-			
16B			306	System battery error	This signal is output when the system battery voltage has dropped (to the warning level).			
17A	N	307	Absolute battery error	This signal is output when the absolute battery voltage has dropped (to the warning level).				
17B			OV input	Connect OV.				

(\*1) This input must be turned OFF. Make sure the signal is not connected.

2-axis Combinations R C P 2

2-axis Combinations R C S 2

3-axis Combinations R C P 2

3-axis Combinations R C S 2

Controllers

Model List

PSEL

SSEL

ROBONET

XSEL



Specification Table

	Item	Specification
Base specifications	Connected actuator	RCS2-series actuator/single-axis robot/linear servo actuator
	Input power supply	Single-phase 100 VAC ±10%
	Power-supply capacity	Max. 1660 VA (400 W, 2-axis operation)
	Dielectric strength	500 VDC, 10 MΩ or more
	Withstand voltage	500 VAC, 1 minute
	Rush current	Max. 30 A
Control specifications	Vibration resistance	XYZ directions: 10 to 57 Hz: (Single amplitude) 0.035 mm (continuous), 0.0 75 mm (intermittent) 58 to 150 Hz: 4.9 m/sec2 (continuous), 9.8 m/sec2 (intermittent)
	Number of controlled axes	1/2
	Maximum total output of connected axes	400 W   800 W
	Position detection method	Incremental encoder/Absolute encoder
Program	Speed setting	1 mm/sec ~ (The maximum limit varies depending on the actuator.)
	Acceleration setting	0.01 G ~ (The maximum limit varies depending on the actuator.)
	Operation method	Program operation/positioner operation (switchable)
	Program language	Super SEL
	Number of programs	128 (*1)
	Number of program steps	9999 (*1)
Communication related	Number of multi-tasking programs	8
	Number of positioning points	20000 (*1)
	Data storage device	Flash ROM (An optional system-memory backup battery can be added.)
	Data input method	Teaching pendant or PC software
	Number of I/O points	24 input points/8 output points (NPN/PNP selectable)
	I/O power supply	24 VDC ±10%, externally supplied
General specifications	PIO cable	CB-DS-PIO□□□ (supplied with the controller)
	Serial communication function	RS232C (half-pitch connector)/USB connector
	Field network cable	(To be supported in the future)
	Motor cable	CB-RCC2-MA□□□ (max. 20 m)
	Encoder cable	CB-RCS2-PA□□□ (max. 20 m)
	Protective functions	Motor overcurrent, motor/driver temperature check, overload check, encoder open check, soft limit overtravel, system battery error, etc.
General specifications	Surrounding air temperature/humidity	0 to 40°C, 10 to 95% (non-condensing)
	Surrounding ambience	Free from corrosive gases or significant dust.
	Protection degree	IP20
	Weight	1.4 kg
	External dimensions	100 mm (W) x 202.6 mm (H) x 126 mm (D)

(\*1) These specifications are different for PNP controllers. Contact IAI for details.

External Dimensions

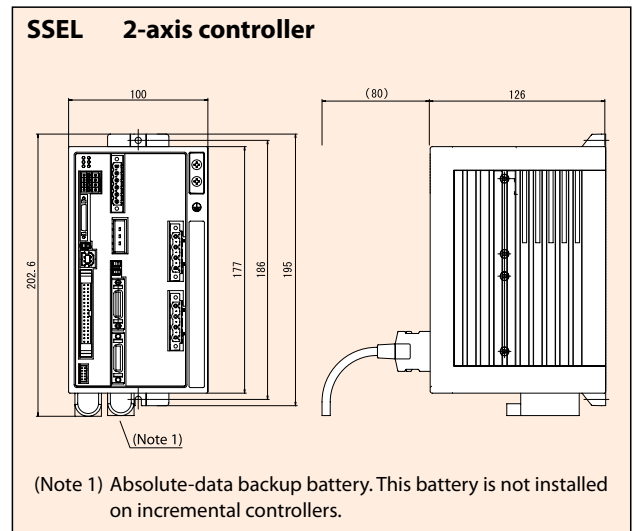
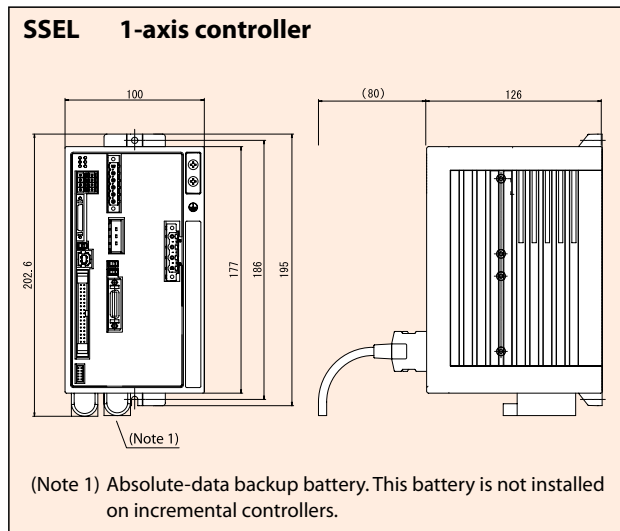

Name of Each Part

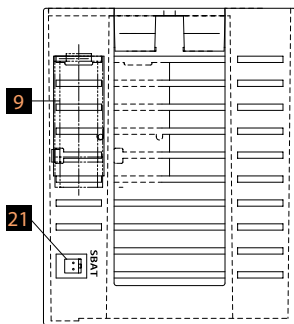
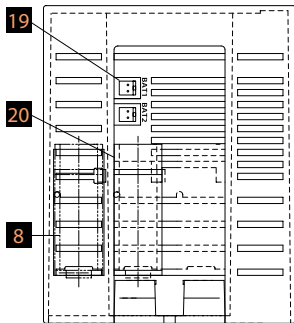
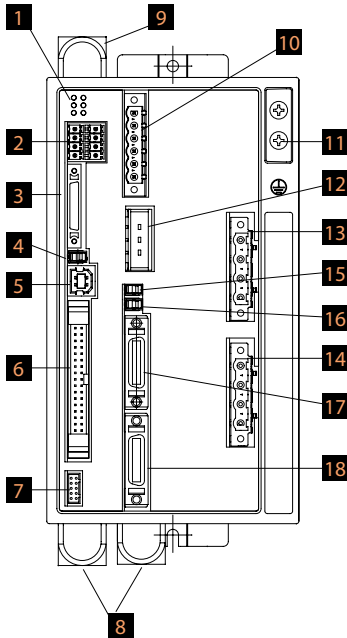

**1** Status indicator LEDs

These LEDs indicate the operating status of the controller. What is indicated by each LED is explained below:

**PWR:** The power is currently input to the controller.

**RDY:** The controller is ready to perform program operation.

**ALM:** The controller is abnormal.

**EMG:** An emergency stop has been actuated and the drive source is being cut off.

**SV1:** The servo of actuator axis 1 is turned ON.

**SV2:** The servo of actuator axis 2 is turned ON.

**2** System I/O connector

This connector connects the emergency stop input, enable input, brake power input, etc.

**3** Teaching pendant connector

This half-pitch, 10Q26-pin connector is used to connect a teaching pendant when the operation mode is MANU. You need a dedicated conversion cable to connect to a conventional D-sub, 25-pin connector.

**4** Mode switch

This switch is used to indicate the operation mode of the controller. The left position indicates the MANU (manual operation) mode, while the right position indicates the AUTO (auto operation) mode. Teaching operation can only be performed in the MANU mode, and auto operation using external I/Os cannot be performed in the MANU mode.

**5** USB connector

This connector is used to make USB connection with a PC. When the USB connector is in use, the TP connector cannot be used because communication through the TP connector is cut off.

**6** IO connector

A connector for interface I/Os. If a DIO (24IN/8OUT) interface is used, this connector accepts a 34-pin flat cable connector. The I/O power is also supplied to the controller through this connector (pins 1 and 34).

**7** Panel unit connector

This connector is used to connect the panel unit (optional) for displaying the controller status and error numbers.

**8** Absolute-data backup battery

This battery is used to retain position data even after the power is cut off when an absolute axis is operated.

**9** System-memory backup battery (optional)

This connector is used to connect the battery needed to retain the various data stored in the built-in SRAM of the controller even after the power is cut off. The system-memory backup battery is an optional. Specify the battery only if necessary.

**10** Power-supply connector

A connector for AC power supply. The control power and motor power are input separately.

**11** Grounding screw

A screw for protective grounding. Be sure to connect this screw to ground.

**12** External regenerative resistor connector

This connector is used to connect an additional regenerative resistor when the built-in regenerative resistor is not enough due to high acceleration, high load, etc.

Whether or not an external regenerative resistor is needed depends on the specifics of the application, such as the axis configuration.

**13** Axis 1 motor connector

Connect the motor cable for actuator axis 1 here.

**14** Axis 2 motor connector

Connect the motor cable for actuator axis 2 here.

**15** Axis 1 brake switch

This switch is used to release the axis brake. When the switch is set to the left (RLS) position, the brake is forcibly released. When the switch is set to the right (NOM) position, the brake is controlled automatically by the controller.

**16** Axis 2 brake switch

This switch is used to release the axis brake. When the switch is set to the left (RLS) position, the brake is forcibly released. When the switch is set to the right (NOM) position, the brake is controlled automatically by the controller.

**17** Axis 1 encoder connector

Connect the encoder cable for actuator axis 1 here.

**18** Axis 2 encoder connector

Connect the encoder cable for actuator axis 2 here.

**19** Axis 1 absolute battery connector

This connector is used to connect the absolute-data backup battery for axis 1 when the actuator is equipped with an absolute encoder.

**20** Axis 2 absolute battery connector

This connector is used to connect the absolute-data backup battery for axis 2 when the actuator is equipped with an absolute encoder.

**21** System-memory backup battery connector

This connector is used to connect the system-memory backup battery.

## Options

### Teaching Pendant

**Features** A teaching device offering functions for program/position input, test operation, monitoring, and more.

**Model/Price**

Model	Description
SEL-T-J	Standard type with connector conversion cable
SEL-TD-J	Deadman switch type with connector conversion cable

**Configuration**

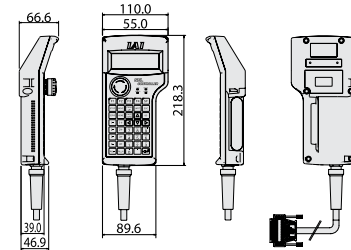
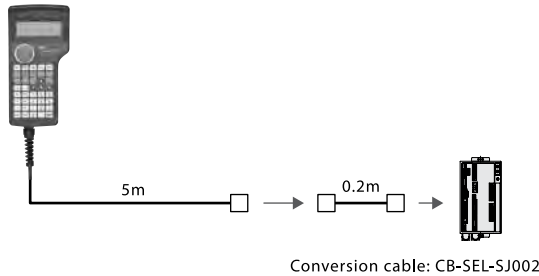

**Specification**

Item	SEL-T-J	SEL-TD-J
3-position enable switch	Not equipped	Equipped
ANSI/UL standard	Not compliant	Compliant
CE mark	Compliant	
Display	20 characters x 4 lines	
Surrounding air temperature/humidity	0-40°C 10-90%RH (non-condensing)	
Protection structure	IP54	
Weight	Approx. 0.4 kg (excluding cables)	

### PC Software (Windows only)

**Features** A software program that assists the initial startup of your system, offering functions for program/position input, test operation, monitoring, and more. The enhanced debugging functions help reduce the startup time.

**Model** **IA-101-X-MW-J** (with RS232C cable + connector conversion cable)  
**IA-101-X-MW** (with RS232C cable)

**Configuration**

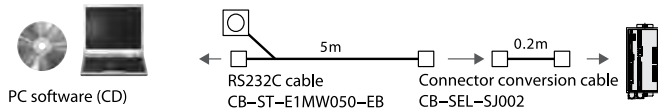

**Model** **IA-101-X-USB** (with USB cable)

**Configuration**

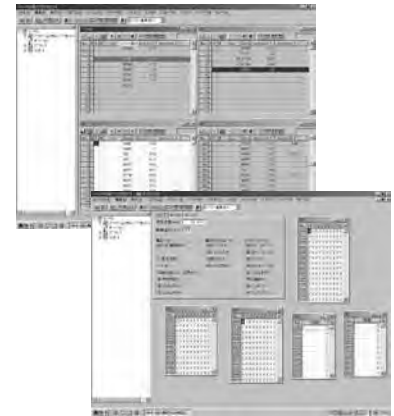
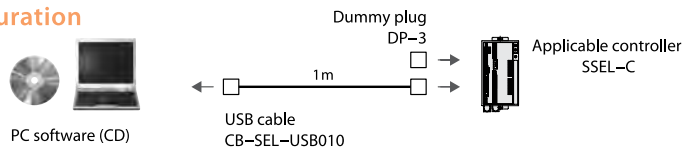

**Note**  
 The SSEL controller only supports version 6.0.0.0 or later.

### Regenerative Resistor Unit

**Features** This unit converts to heat the regenerative current produced when the motor decelerates. Use the table on the right to check the total wattage of the actuators to be operated, and provide a regenerative resistor or resistors if necessary.

**Item** **REU-2** (for SCON/SSEL)

**Specification**

Weight	0.9kg
Built-in regenerative resistor	220Ω 80W
Unit-controller connection cable (supplied)	CB-SC-REU010 (for SSEL)

**Guide for Determining Necessary Number of Regenerative Resistor Units**

	Horizontal	Vertical
0 unit	~800W	~200W
1 unit		~600W
2 unit		~800W

\* Depending on the operating conditions, the required number of regenerative resistor unit(s) may be more than what is specified above.

\* If two regeneration units are required, order one REU-2 and one REU-1 (refer to P. 132).

**External Dimensions**

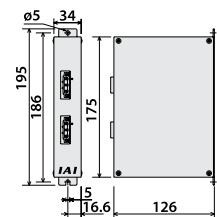

### Panel Unit

**Features** A display for checking controller error codes and the program number of the current program.

**Model** **PU-1** (cable length: 3 m)

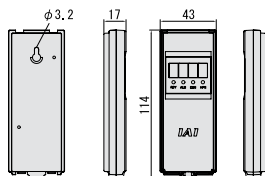

### Absolute-data Backup Battery

**Features** An absolute-data backup battery used when an absolute actuator is operated. The battery is the same as the system-memory backup battery.

**Model** **AB-5**



### System memory backup battery

**Features** This battery is needed when global flags, etc., are used in the program and you want the data to be retained even after the power is turned off.

**Model** **AB-5-CS** (with case)  
**AB-5** (battery)



Options

Dummy plug

**Features** This plug is connected to the teaching pendant to cut off the enable circuit when connecting the SSEL controller to a PC via a USB cable. (This plug is supplied with the PC software IA-101-X-USB.)

**Model** DP-3



USB cable

**Features** This cable is used to connect a controller with USB port to a PC. To connect a controller without USB port (XSEL) to a PC, connect the controller's RS232C cable to a USB cable via a USB conversion adapter and connect the USB cable to the USB port on the PC. (Refer to the PC software IA-101-X-USBMW.)

**Model** CB-SEL-USB010 (cable length: 1 m)



Connector conversion cable

**Features** This conversion cable is used to connect the D-sub, 25-pin connector for teaching pendant or PC to the teaching connector (half-pitch) on the SSEL controller.

**Model** CB-SEL-SJ002 (cable length: 0.2 m)



Replacement Parts

If you must order a replacement cable, etc., after the initial purchase of your product, specify the correct model by referring to the information below.

Motor Cable/Robot Motor Cable

Item **CB-RCC-MA**□□□□ / **CB-RCC-MA**□□□□-RB

\* □□□□ indicates the cable length (L). A desired length up to 30 m can be specified. Example) 080 = 8 m

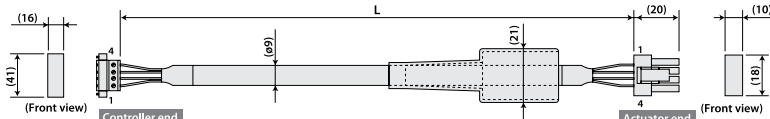

Wire	Color	Signal	No.	Signal	Color	Wire
0.75sq	Green	PE	1	1	U	Red
	Red	U	2	2	V	White
	White	V	3	3	W	Black
	Black	W	4	4	PE	Green

Encoder Cable/Robot Encoder Cable

Item **CB-RCS2-PA**□□□□ / **CB-X3-PA**□□□□

\* □□□□ indicates the cable length (L). A desired length up to 30 m can be specified. Example) 080 = 8 m

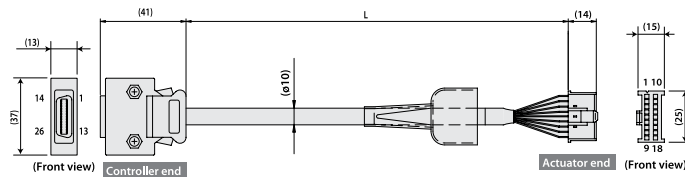

Wire	Color	Signal	No.	No.	Signal	Color	Wire
AWG26 (Soldered)	White	A+	1	1	A	White/Blue	AWG26 (Crimped)
	White	A-	2	2	B	White/Orange	
	White	B+	3	3	B	White/Blue	
	White	B-	4	4	CRSP	Brown/Yellow	
	Green	VCC	16	5	OT	Brown/Red	
	Green	VCC	16	6	RSV	Brown/Black	
	Brown	GND	17	7	LS	Orange/White	
	Gray	SRD+	20	8	LS+	Green/White	
	Red	SRD-	21	9	LS-	Brown/White	
	Black	BAT+	14	10	FG	Ground	
	Yellow	BAT-	15	10	SD	Blue	
	Green	VCC	16	11	SP	Orange	
	Black	GND	17	12	BAT+	Black	
	Gray	SRD+	20	13	BAT-	Yellow	
	Red	SRD-	21	14	VCC	Green	
	Black	SRD-	22	15	GND	Brown	
	White	SRD+	23	16	LS	Gray/White	
	White	SRD-	24	17	LS+	Gray/White	
	White	SRD+	25	18	LS-	Red	

Encoder Cable/Robot Encoder Cable for RCS2-RT6/RT6R/RT7R

Item **CB-RCS2-PLA**□□□□ / **CB-X2-PLA**□□□□

\* □□□□ indicates the cable length (L). A desired length up to 30 m can be specified. Example) 080 = 8 m

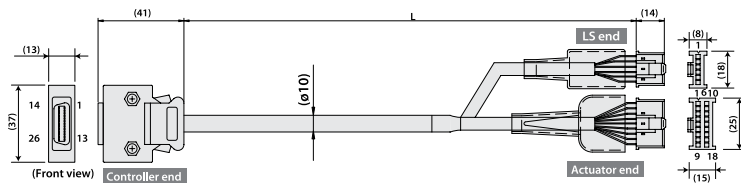

Wire	Color	Signal	No.	No.	Signal	Color	Wire
AWG26 (Soldered)	White/Orange	E4V	11	1	A	White/Blue	AWG26 (Crimped)
	White/Green	OV	13	2	OV	White/Green	
	Brown/Blue	LS	26	3	LS	Brown/Blue	
	Brown/Red	CRSP	25	4	CRSP	Brown/Yellow	
	Brown/Black	OT	24	5	OT	Brown/Red	
	Green/Black	RSV	23	6	RSV	Brown/Black	
	White	A+	1	7	LS	Orange/White	
	White	A-	2	8	LS+	Green/White	
	White	B+	3	9	LS-	Brown/White	
	White	B-	4	10	SD	Blue	
	Green	VCC	16	11	SP	Orange	
	Green	VCC	16	12	BAT+	Black	
	Brown	GND	17	13	BAT-	Yellow	
	Gray	SRD+	20	14	VCC	Green	
	Red	SRD-	21	15	GND	Brown	
	Black	SRD-	22	16	LS	Gray/White	
	White	SRD+	23	17	LS+	Gray/White	
	White	SRD-	24	18	LS-	Red	

I/O Flat Cable

Item **CB-DS-PIO**□□□□

\* □□□□ indicates the cable length (L). A desired length up to 10 m can be specified. Example) 080 = 8 m

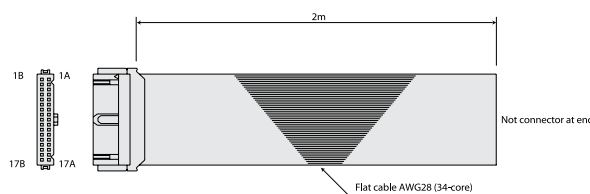

No.	Color	Wire	No.	Color	Wire
1A	Brown 1		9B	Gray 2	
1B	Red 1		10A	White 2	
2A	Orange 1		10B	Black 2	
2B	Yellow 1		11A	Brown-3	
3A	Green 1		11B	Red 3	
3B	Blue 1		12A	Orange 3	
4A	Purple 1		12B	Yellow 3	
4B	Gray 1		13A	Green 3	
5A	White 1		13B	Blue 3	
5B	Black 1		14A	Purple 3	
6A	Brown-2		14B	Gray 3	
6B	Red 2		15A	White 3	
7A	Orange 2		15B	Black 3	
7B	Yellow 2		16A	Brown-4	
8A	Green 2		16B	Red 4	
8B	Blue 2		17A	Orange 4	
9A	Purple 2		17B	Yellow 4	

2-axis Combinations RCP2  
2-axis Combinations RCS2  
3-axis Combinations RCP2  
3-axis Combinations RCS2  
Controllers  
Model List  
PSEL  
SSEL  
ROBONET  
XSEL

# X-SEL

RCS2-series  
program controller



## Model List/Pricing

A multi-axis program controller capable of operating RCS2-series actuators. Up to six axes can be controlled simultaneously.

Type	J	K	P	Q
Name	Small type	General-purpose type	Large-capacity type	Large-capacity type (conforming to safety category)
Exterior view				
Description	A small, low-cost type ideal for operating low-output actuators	A standard type offering great expandability	A large-capacity type capable of operating up to six axes or 2400 W	A large-capacity type that can be configured to meet safety category 4
Maximum number of controlled axes	4		6	
Number of positions	3000		4000	
Total wattage of connectable axes	800W	1600W	2400W	
Power supply	Single-phase 100 VAC, Single-phase 200 VAC		Single-phase 200 VAC, Three-phase 200 VAC	
Safety category	B		B	Can be configured to meet category 4.
Safety standard	-		CE	CE, ANSI
Standard price	Contact IAI.			

## Model

### [XSEL-J/K Types]

\* If you are selecting multiple options, specify them in an alphabetical order. (Example: Brake + Home sensor [ BL

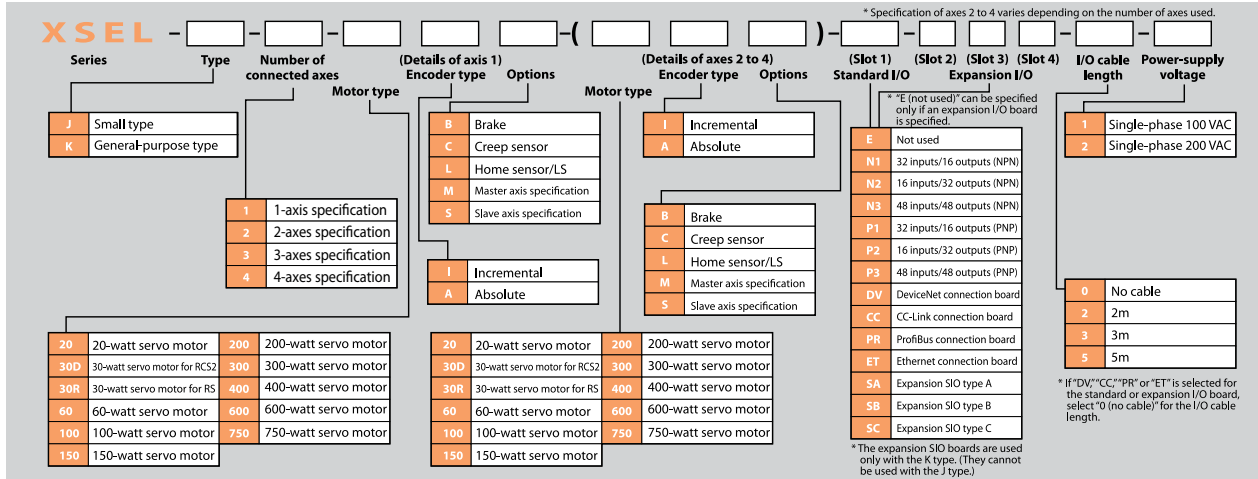

### [XSEL-P/Q Types]

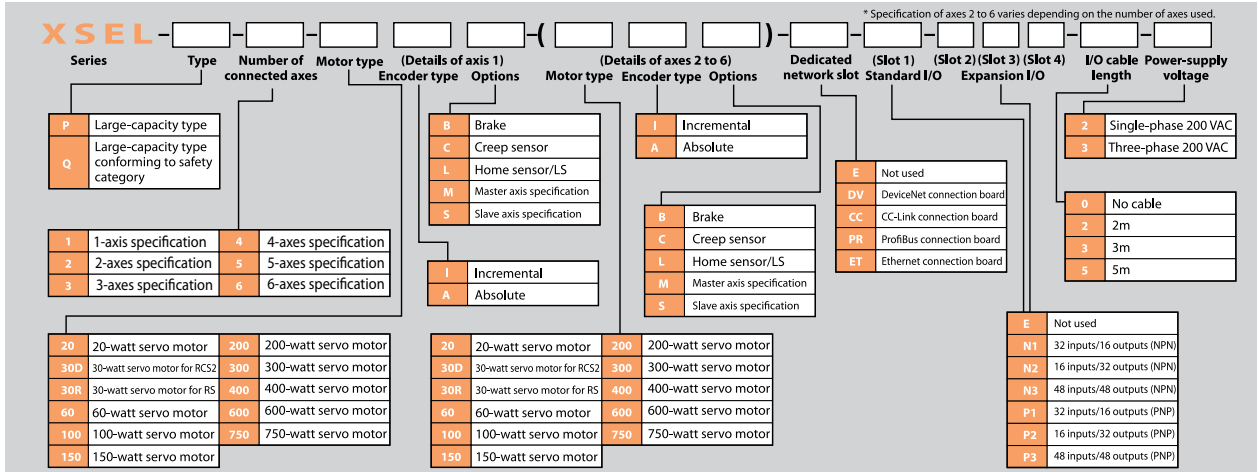

Regenerative resistor unit

J (Small Type)/K (General-purpose Type)/KE (CE Type)

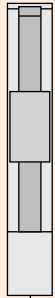

■ Connectable actuators

- High-speed, high-precision type ISPA series
- Standard type ISA series
- Dustproof type ISDA series
- Clean room specification ISDACR series
- Antistatic specification ISDACR ESD
- High-rigidity belt type IF series
- Slim belt type FS series
- Rotational axis RS series
- ROBO Cylinder RCS2 series

Standard motor cable, 3 m/5 m (Refer to P. 133.)  
Standard encoder cable, 3 m/5 m (Refer to P. 134.)  
(Supplied with the actuator)

Regeneration unit cable, 1 m  
(Supplied with the regeneration unit)

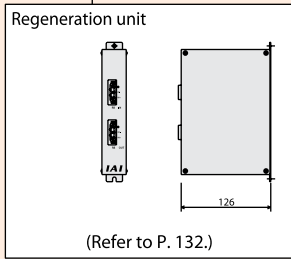

■ External devices

- Parts feeder
- Solenoid valve
- PLC

I/O flat cable, 2 m  
(Supplied with the controller)  
(Refer to P. 134.)

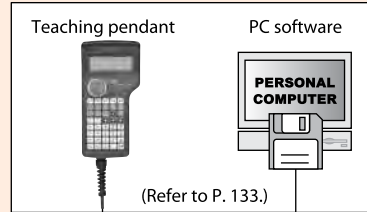

(Refer to P. 133.)

RS232 cable, 5 m (Refer to P. 133.)  
(Supplied with the PC software)

■ Main power supply

- Single-phase 100 VAC
- Single-phase 200 VAC

■ I/O power supply

- DC24V

■ System I/Os

- Emergency stop
- Enable
- System ready

■ Various field networks

- Device Net (Refer to P. 132.)
- CC-Link (Refer to P. 132.)
- Profi Bus
- Ethernet

■ Serial communication unit

- Expansion SIO board (Refer to P. 132.)  
RS232C/RS422/RS485

P (Large-capacity Type)/Q (Large-capacity Global Type)

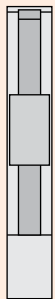

■ Connectable actuators

- High-speed, high-precision type ISPA series
- Standard type ISA series
- Dustproof type ISDA series
- Clean room specification ISDACR series
- Antistatic specification ISDACR ESD
- High-rigidity belt type IF series
- Slim belt type FS series
- Rotational axis RS series
- Linear servo LSA series
- ROBO Cylinder RCS2 series

Standard motor cable, 3 m/5 m (Refer to P. 133.)  
Standard encoder cable, 3 m/5 m (Refer to P. 134.)  
(Supplied with the actuator)

Regeneration unit cable, 1 m  
(Supplied with the regeneration unit)

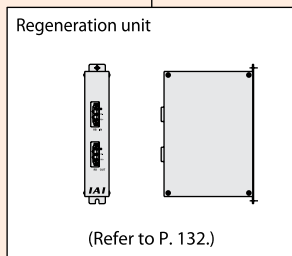

■ External devices

- PLC, etc.

I/O flat cable, 2 m  
(Supplied with the controller)  
(Refer to P. 134.)



■ Serial communication port 2 channels of standard and RS232

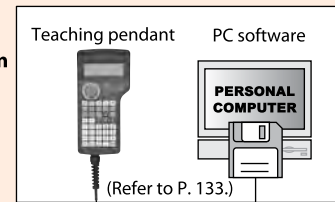

(Refer to P. 133.)

RS232 cable, 5 m (Refer to P. 133.)  
(Supplied with the PC software)

■ Control power supply

- Single-phase 200 VAC

■ Motor-drive power supply

- Three-phase 200 VAC (Q type)

■ System I/Os

- Emergency stop
- Enable
- System ready

■ Expansion I/Os

- PIO board
- \* If an expansion I/O board is installed on the P or Q type, the controller enclosure will be changed. (Refer to P. 129.)

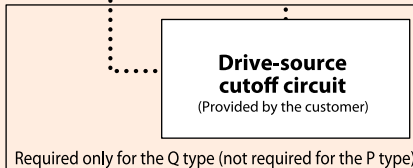

2-axis Combinations R C P 2  
2-axis Combinations R C S 2  
3-axis Combinations R C P 2  
3-axis Combinations R C S 2  
Controllers

Model List  
PSEL  
SSEL  
ROBONET  
XSEL



I/O Wiring

Input External input specifications (NPN specification)

Item	Specification
Input voltage	DC24V ±10%
Input current	7 mA per circuit
ON/OFF voltages	ON voltage --- Min. 16.0VDC / OFF voltage --- Max. 5.0 VDC
Insulation method	Photo-coupler insulation
Externally connected devices	[1] No-voltage contacts (minimum load of approx. 5 VDC/1 mA) [2] Photoelectric/proximity sensors (NPN type) [3] Sequencer transistor outputs (open-collector type) [4] Sequencer contact outputs (minimum load of approx. 5 VDC/1 mA)

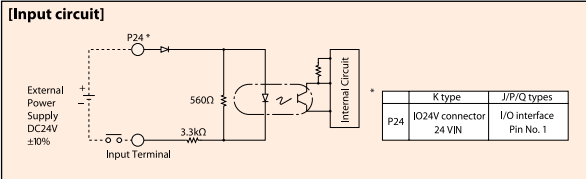

Input External input specifications (PNP specification)

Item	Specification
Input voltage	DC24V ±10%
Input current	7 mA per circuit
ON/OFF voltages	ON voltage --- Min. 8.0 VDC / OFF voltage --- Max. 19.0 VDC
Insulation method	Photo-coupler insulation
Externally connected devices	[1] No-voltage contacts (minimum load of approx. 5 VDC/1 mA) [2] Photoelectric/proximity sensors (PNP type) [3] Sequencer transistor outputs (open-collector type) [4] Sequencer contact outputs (minimum load of approx. 5 VDC/1 mA)

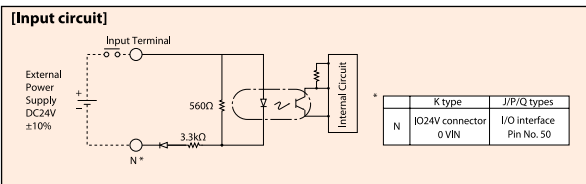

Output External output specifications (NPN specification)

Item	Specification
Load voltage	DC24V
Maximum load current	100 mA per point, 400 mA peak (total current)
Leak current (max.)	Max. 0.1 mA per point
Insulation method	Photo-coupler insulation
Externally connected devices	[1] Miniature relays [2] Sequence input units

TD62084 (or equivalent) is used.

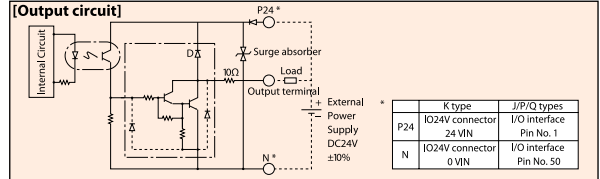

Output External output specifications (PNP specification)

Item	Specification
Load voltage	DC24V
Maximum load current	100 mA per point 400 mA per 8 ports Note)
Leak current (max.)	Max. 0.1 mA per point
Insulation method	Photo-coupler insulation
Externally connected devices	[1] Miniature relays [2] Sequence input units

TD62784 (or equivalent) is used.

Note) The maximum total load current for every eight ports from output port No. 300 is 400 mA. (The maximum total load current of output port Nos. 300+n to 300+n+7 is 400 mA, where n is 0 or a multiple of 8.)

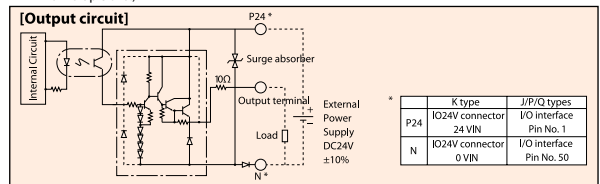

I/O Signal Tables

Standard I/O Signal Table (When N1 or P1 is selected)

Pin No.	Category	Port No.	Standard setting
1		—	I/P/Q types: 24-V connection / K type: NC
2		000	Program start
3		001	General-purpose input
4		002	General-purpose input
5		003	General-purpose input
6		004	General-purpose input
7		005	General-purpose input
8		006	General-purpose input
9		007	Program specification (PRG No. 1)
10		008	Program specification (PRG No. 2)
11		009	Program specification (PRG No. 4)
12		010	Program specification (PRG No. 8)
13		011	Program specification (PRG No. 10)
14		012	Program specification (PRG No. 20)
15		013	Program specification (PRG No. 40)
16	Input	014	General-purpose input
17		015	General-purpose input
18		016	General-purpose input
19		017	General-purpose input
20		018	General-purpose input
21		019	General-purpose input
22		020	General-purpose input
23		021	General-purpose input
24		022	General-purpose input
25		023	General-purpose input
26	024	General-purpose input	
27	025	General-purpose input	
28	026	General-purpose input	
29	027	General-purpose input	
30	028	General-purpose input	
31	029	General-purpose input	
32	030	General-purpose input	
33	031	General-purpose input	
34	Output	300	Alarm output
35		301	Ready output
36		302	Emergency stop output
37		303	General-purpose output
38		304	General-purpose output
39		305	General-purpose output
40		306	General-purpose output
41		307	General-purpose output
42		308	General-purpose output
43		309	General-purpose output
44		310	General-purpose output
45		311	General-purpose output
46		312	General-purpose output
47		313	General-purpose output
48		314	General-purpose output
49		315	General-purpose output
50		—	I/P/Q types: 0-V connection / K type: NC

Expansion I/O Signal Table (When N1 or P1 is selected)

Pin No.	Category	Standard setting
1		I/P/Q types: 24-V connection / K type: NC
2	Input	General-purpose input
3		General-purpose input
4		General-purpose input
5		General-purpose input
6		General-purpose input
7		General-purpose input
8		General-purpose input
9		General-purpose input
10		General-purpose input
11		General-purpose input
12		General-purpose input
13		General-purpose input
14		General-purpose input
15		General-purpose input
16		General-purpose input
17		General-purpose input
18		General-purpose input
19		General-purpose input
20		General-purpose input
21		General-purpose input
22		General-purpose input
23		General-purpose input
24		General-purpose input
25		General-purpose input
26		General-purpose input
27		General-purpose input
28		General-purpose input
29		General-purpose input
30		General-purpose input
31		General-purpose input
32	General-purpose input	
33	General-purpose input	
34	General-purpose output	
35	General-purpose output	
36	General-purpose output	
37	General-purpose output	
38	General-purpose output	
39	General-purpose output	
40	General-purpose output	
41	General-purpose output	
42	General-purpose output	
43	General-purpose output	
44	General-purpose output	
45	General-purpose output	
46	General-purpose output	
47	General-purpose output	
48	General-purpose output	
49	General-purpose output	
50		I/P/Q types: 0-V connection / K type: NC

Expansion I/O Signal Table (When N2 or P2 is selected)

Pin No.	Category	Standard setting
1		I/P/Q types: 24-V connection / K type: NC
2	Input	General-purpose input
3		General-purpose input
4		General-purpose input
5		General-purpose input
6		General-purpose input
7		General-purpose input
8		General-purpose input
9		General-purpose input
10		General-purpose input
11		General-purpose input
12		General-purpose input
13		General-purpose input
14		General-purpose input
15		General-purpose input
16		General-purpose input
17		General-purpose input
18		General-purpose output
19		General-purpose output
20		General-purpose output
21		General-purpose output
22		General-purpose output
23		General-purpose output
24		General-purpose output
25		General-purpose output
26		General-purpose output
27		General-purpose output
28		General-purpose output
29		General-purpose output
30		General-purpose output
31		General-purpose output
32	General-purpose output	
33	General-purpose output	
34	Output	General-purpose output
35		General-purpose output
36		General-purpose output
37		General-purpose output
38		General-purpose output
39		General-purpose output
40		General-purpose output
41		General-purpose output
42		General-purpose output
43		General-purpose output
44		General-purpose output
45		General-purpose output
46		General-purpose output
47		General-purpose output
48		General-purpose output
49		General-purpose output
50		

Specification Table

■ J (Small Type)/K (General-purpose Type)

Item	Description													
Controller series/type	J (small type)						K (general-purpose type)/KE (CE type)							
Connected actuators	RCS2/ISA/ISPA/ISP/ISDA/ISDACR/ISPDACR/IF/FS/RS													
Applicable motor output (W)	20/30/60/100/150/200/300/400/600/750													
Number of connected axes	1	2	3	4	5	6	1	2	3	4	5	6		
Maximum output of connected axes (W)	Max 800 (at power-supply voltage of 200 V) Max 400 (at power-supply voltage of 100 V)						Max 1600 (at power-supply voltage of 200 V) Max 800 (at power-supply voltage of 200 V)							
Input power supply	100-V specification: Single-phase 100 to 115 VAC 200-V specification: Single-phase 200 to 230 VAC													
Operating power-supply voltage range	±10%													
Power-supply frequency	50Hz/60Hz													
Power-supply capacity	Max 1670VA		Max 1720VA		Max 1810VA		Max 1670VA		Max 3120VA		Max 3220VA		Max 3310VA	
Position detection method	Incremental encoder (wire-saving type) Multi-rotation data backup absolute encoder (wire-saving type)													
Speed setting	1 mm/sec ~ (The maximum limit varies depending on the actuator.)													
Acceleration setting	0.01 G ~ (The maximum limit varies depending on the actuator.)													
Program language	Super SEL													
Number of programs	64													
Number of program steps	6,000 (total)													
Number of multi-tasking programs	16													
Number of positions	3,000													
Data storage device	Flash ROM + SRAM backup battery													
Data input method	Teaching pendant or PC software													
Standard I/Os	32 points (total of dedicated inputs + general-purpose inputs)/16 points (total of dedicated outputs + general-purpose outputs)													
Expansion I/Os	None			1 unit, 48 points (1 unit can be added)			1 unit, 48 points (Up to 3 units can be added)							
Serial communication function	Standard RS232 port (D-sub, 25-pin)						Standard RS232 port + Expansion SIO board (optional)							
Other I/Os	System I/Os (emergency stop input, enable input, system ready output)													
Protective functions	Motor overcurrent, overload, motor/driver temperature check, overload check, encoder open detection, soft limit overtravel, system error, battery error, etc.													
Surrounding air temperature/humidity	Temperature 0 to 40°C, humidity 30 to 85%													
Surrounding ambience	Free from corrosive gases or significant dust.													
Weight	2.6kg		3.3kg		5.0kg		6.0kg		7.0kg					
Accessory	I/O flat cable													

■ P (Large-capacity Type)/Q (Large-capacity Type Conforming to Safety Category)

Item	Description															
Controller series/type	P (standard) type						Q (global) type									
Connected actuators	RCS2/ISA/ISPA/ISP/ISDA/ISDACR/ISPDACR/IF/FS/RS/LSA															
Applicable motor output	20/30/60/100/150/200/300/400/600/750															
Number of controlled axes	1	2	3	4	5	6	1	2	3	4	5	6				
Maximum output of connected axes (W)	Max2400W (1600 W for single-phase 200-VAC specification)															
Control power input	AC 200/230, single-phase -15%, +10%						AC 200/230, single-phase -15%, +10%									
Motor power input	AC 200/230, single-phase/three-phase -10%, +10%						AC 200/230, single-phase/three-phase -10%, +10%									
Power-supply frequency	50/60Hz															
Insulation resistance	10MΩ or more (at 500 VDC, between the power-supply terminal and each I/O terminal and between all external terminals and the case)															
Withstand voltage	1500 VAC (1 minute)						1500 VAC (1 minute)									
Power-supply capacity (*1)	Max 1744VA	Max 3266VA	Max 4787VA	Max 4878VA	Max 4931VA	Max 4998VA	Max 1744VA	Max 3266VA	Max 4787VA	Max 4878VA	Max 4931VA	Max 4998VA				
Position detection method	Incremental encoder (wire-saving type) Multi-rotation data backup absolute encoder (wire-saving type)															
Safety circuit configuration	Redundancy not supported						Redundancy supported									
Drive-source cutoff method	Internal cutoff relay						External safety circuit									
Enable input	Contact B input (power supplied internally)						Contact B input (power supplied externally, redundant)									
Speed setting	1 mm/sec ~ (The maximum limit varies depending on the actuator.)															
Acceleration setting	0.01 G ~ (The maximum limit varies depending on the actuator.)															
Program language	Super SEL															
Number of programs	64															
Number of program steps	6,000 (total)															
Number of multi-tasking programs	16															
Number of positions	4,000 (total)															
Data storage device	Flash ROM + SRAM backup battery															
Data input method	Teaching pendant or PC															
Standard I/Os	1 of PIO board with 48 I/O points (NPN/PNP) or PIO board with 96 I/O points (NPN/PNP) can be installed.															
Expansion I/Os	Up to 3 of PIO board with 48 I/O points (NPN/PNP) and/or PIO board with 96 I/O points (NPN/PNP) can be installed.															
Serial communication function	Standard teaching port (D-sub, 25-pin) + 2-channel RS232C port (D-sub, 9-pin x 2)															
Protective functions	Motor overcurrent, overload, motor/driver temperature check, overload check, encoder open detection, soft limit overtravel, system error, battery error															
Surrounding air temperature/humidity, ambience	0 to 40°C, 10 to 95% (non-condensing); free from corrosive gases or significant dust.															
Weight (*2)	5.2kg				5.7kg				4.5kg				5kg			
Accessory	I/O flat cable															

\*1 When axes corresponding to the maximum wattage are connected.

\*2 Including the absolute battery, brake mechanism and expansion I/O box.



**External Dimensions**

**■ J (Small Type)/K (General-purpose Type)**

	1-axis specification	2-axis specification	3/4-axis specification	Side view
J type (Small type)				
K type (General-purpose type)	1/2-axis specification		3/4-axis specification	

**■ P (Large-capacity Standard Type)/Q (Large-capacity Global Type)**

The shapes and dimensions of SEL-P/Q types vary depending on the controller specifications (encoder type, with/without brake, and with/without I/O expansion).

The following four shapes are available. Check the applicable dimensions based on the desired type and number of axes to be connected.

		Base shape (incremental specification)	With brake/absolute unit	With I/O expansion base	With brake/absolute unit + I/O expansion base	Side view
Controller specification	Encoder	Incremental	Absolute	Incremental	Absolute	
	Brake	Not equipped	Equipped	Not equipped	Equipped	
	I/O	Standard only	Standard only	Standard + Expansion	Standard + Expansion	
P type (Large-capacity)	1 to 4-axis specification					
	5 to 6-axis specification					
Q type (Large capacity conforming to safety standard) <small>* The dimensions of single phase 200VAC controllers conform to those of the P type.</small>	1 to 4-axis specification					
	5 to 6-axis specification					

Name of Each Part

J Type (Small)

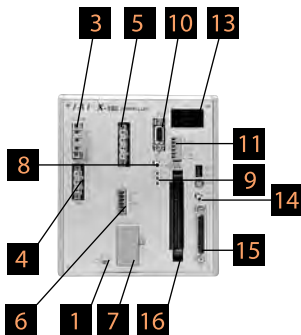

K Type (General-purpose)

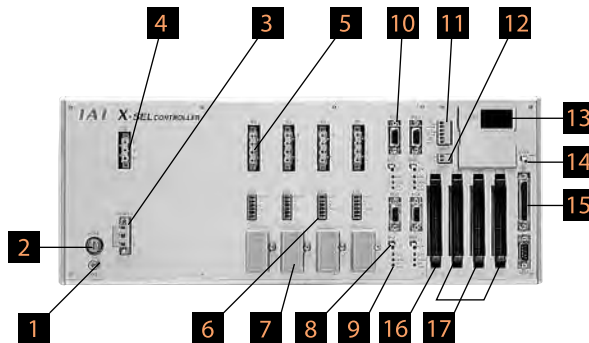

**1** FG connection terminal

A connection edge to connect the FG terminal of the enclosure. This terminal is connected to the PE terminal of the AC input part internally through the controller.

**2** Fuse holder (K type only)

A half-cut fuse holder for protecting the AC input part from overcurrent.

**3** Main-power input connector

A connector for 100/200-VAC single-phase input. (This connector comes with a cable-end plug. Refer to the right page.)

**4** Regenerative-resistor unit connector

This connector is used to connect the regenerative resistor unit (optional: REU-1) that may be required if the built-in regenerative connector is not enough due to high acceleration, high load, etc.

**5** Motor cable connector

A connector for the motor power cable of the actuator motor.

**6** Actuator-sensor input connector

A connector for the LS, CREEP, OT and other axis sensors.

**7** Absolute-data backup battery

A battery unit for backing up the absolute encoder if used. This battery is not connected to non-absolute axes.

**8** Brake release switch (brake specification only)

An alternate switch with lock for releasing the axis brake. To operate this switch, pull the switch toward you and then tilt it to a desired position. Tilt the switch to the top (RLS) position to forcibly release the brake, or tilt it to the bottom (NOM) position to let the controller control the brake automatically.

**9** Axis-driver status LEDs

These LEDs are used to monitor the operating status of the driver CPU that controls the motor drive. The following three LEDs are provided.

Name	Color	Meaning when the LED is lit
ALM	Orange	The driver has detected an error.
SVON	Green	The servo is ON and the motor is being driven.
BATT ALM	Orange	The absolute battery voltage is low.

**10** Encoder cable connector

This 15-pin, D-sub connector is used to connect the encoder cable of the actuator.

**11** System IO connector

This connector has a total of three I/Os including two inputs for controlling the controller operation and one output regarding the system status. (This connector comes with a cable-end plug. Refer to the right page.)

Name		
EMG	Emergency stop input	Operation is enabled when this signal is ON. An emergency stop is actuated when the signal turns OFF.
ENB	Safety gate input	Operation is enabled when this signal is ON. The servo turns OFF when the signal turns OFF.
RDY	System ready relay output	The controller status is output. Cascade connection is supported. The controller is ready when the output contacts are shorted and not ready when the contacts are open.

**12** IO24V power connector (K type only)

If DI/DOs are installed in the IO slots **16**, **17**, this connector is used to supply the I/O power to the insulated part externally.

**13** Panel window

The 4-digit 7-segment LED display and five LED lamps indicating the system status can be visually checked.

**14** Mode switch

An alternate switch with lock for specifying the operation mode of the controller. To operate this switch, pull the switch toward you and then tilt it to a desired position. The top position indicates the MANU (manual operation) mode, while the bottom position indicates the AUTO (auto operation) mode. Teaching operation can only be performed in the MANU mode, and auto operation using external IOs cannot be performed in the MANU mode.

**15** Teaching connector

This D-sub, 25-pin connector is used to connect a teaching pendant or PC to input program positions.

**16** Standard I/O slot (slot 1)

The standard PIO board with 32 input points and 16 output points is installed in this slot.

**17** Expansion I/O slots (slot 2, slot 3, slot 4)

An expansion IO board (optional) can be installed in each of these slots.

2-axis  
Combinations  
R C P 2

2-axis  
Combinations  
R C S 2

3-axis  
Combinations  
R C P 2

3-axis  
Combinations  
R C S 2

Controllers

Model  
List

PSEL

SSEL

ROBONET

XSEL

**P type (standard, 4-axis)**

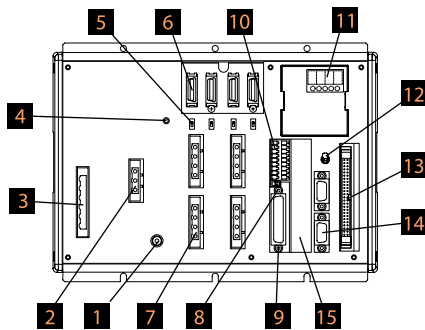

**Q type (with absolute brake unit + expansion base, 6-axis)**

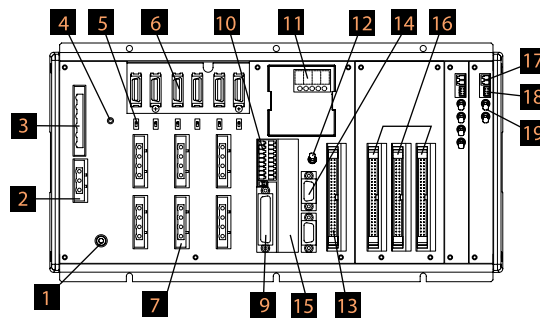

**1 FG connection terminal**

A connection edge to connect the FG terminal of the enclosure. This terminal is connected to the PE terminal of the AC input part internally through the controller.

**2 External regeneration unit connector**

This connector is used to connect an additional regenerative resistor when the built-in regenerative resistor is not enough due to high acceleration, high load, etc. Whether or not an external regenerative resistor is needed depends on the specifics of the application, such as the axis configuration.

**3 AC-power input connector**

A connector for 200-VAC three-phase input. This connector consists of six terminals including the motor power-supply, control power-supply and PE terminals.

The standard specification only comes with a terminal block.

**Caution** To prevent electric shock, do not touch this connector while the power is supplied.

**4 Control power-supply monitor LED**

A green light is lit while the control power supply is generating the internal controller power properly.

**5 Absolute-battery enable/disable switch**

This switch is used to enable or disable the encoder backup operation using the absolute battery. The factory setting is to disable the backup. Connect the encoder and axes-sensor cables, turn on the power, and then set this switch to the top position.

**6 Encoder/axis-sensor connector**

A connector for the actuator encoder and axis sensors such as LS, CREEP and OT. \*: LS, CREEP and OT sensors are optional.

**7 Motor connector**

A connector for driving the motor in the actuator.

**8 Teaching-pendant type selector switch**

This switch is used to change the type of the teaching pendant connected to the teaching connector **9**. You can switch between IAI's standard teaching pendant and ANSI teaching pendant. Set the switch provided on the front side of the board according to the teaching pendant to be used.

**9 Teaching connector**

This teaching interface is used to connect IAI's teaching pendant or PC (PC software) to operate, set or otherwise manipulate the system.

**10 System I/O connector**

This I/O connector controls the safety operations of the controller. With the global specification, this connector can be used, together with an external safety circuit, to configure a safety circuit meeting up to category 4.

**11 Panel window**

The panel window consists of the 4-digit, 7-segment LED display and five LED lamps indicating the status of the system.

Meanings of 5 LEDs

Name	Condition when the LED is lit
RDY	The CPU is ready (to perform program operation).
ALM	A CPU alarm (system-shutdown level error) or CPU hardware error is present.
EMG	An emergency stop is actuated or CPU hardware error or power-supply hardware error is present.
PSE	A power-supply hardware error is present.
CLK	The system clock is abnormal.

**12 Mode switch**

An alternate switch with lock for specifying the operation mode of the controller. To operate this switch, pull the switch toward you and then tilt it to a desired position. The top position indicates the MANU (manual operation) mode, while the bottom position indicates the AUTO (auto operation) mode. Teaching operation can only be performed in the MANU mode, and auto operation using external I/Os cannot be performed in the MANU mode.

**13 Standard I/O connector**

Overview of standard IO interface specifications

Item	Photo-coupler
Connector name	I/O
Applicable connector	Flat connector, 50-pins
Power supply	Power is supplied from connector pin Nos. 1 and 50.
Inputs	32 points (including general-purpose and dedicated inputs)
Outputs	16 points (including general-purpose and dedicated outputs)
Connected to	External PLC, sensor, etc.

**14 General-purpose RS232C port connector**

This port is used to connect general-purpose RS232C devices. (Two channels are provided.)

**15 Field-network board slot**

A fieldbus interface module is installed in this slot.

**16 Expansion I/O boards (optional)**

Optional expansion boards are installed in these slots.

**17 Brake-power input connector**

A power input connector for driving the brake of the actuator. 24 VDC must be supplied externally. If the specified power is not supplied, the actuator brake cannot be released. Be sure to supply this power to axes with brake. For the brake power cable, use a shielded cable and connect the shield on the 24-V power supply side.

**18 Brake-release switch connector**

This connector is used to connect a switch that releases the actuator brake from outside the controller. The brake is released when the COM and BKMRL\* terminals of this connector are shorted. Use this connector if you want to manually operate the actuator when the controller power is cut off or other abnormality is present.

**19 Brake switch**

An alternate switch with lock for releasing the axis brake. To operate this switch, pull the switch toward you and then tilt it to a desired position. Tilt the switch to the top (RLS) position to forcibly release the brake, or tilt it to the bottom (NOM) position to let the controller control the brake automatically.

Options

Regenerative Resistor Unit

Model **REU-1**

Description

This unit converts to heat the regenerative current produced when the motor decelerates. Although the controller has a built-in regenerative resistor, a regeneration unit or units may be required if its capacity is not enough for the vertical axis load. (Refer to the table on the right.)

Specification

Item	Specification
Dimensions	W34mm×H195mm×D126mm
Weight	0.9kg
Built-in regenerative resistor	220Ω 80W
Accessory	Controller connection cable (model: CB-ST-REU101), 1 m

**Installation Standards** Determine the required number of unit(s) according to the total motor capacity of the connected vertical axes.

Horizontal application

Motor wattage	P/Q type	J type	K type
~200W	Not required	Not required	Not required
~800W	1 unit	Not required	Not required
~1000W	1 unit	-	Not required
~1500W	2 units	-	Not required
~2000W	3 units	-	-
~2400W	4 units	-	-

Vertical application

Motor wattage	P/Q type	J type	K type
~100W	Not required	Not required	Not required
~200W	1 unit	Not required	Not required
~400W	1 unit	1 unit	Not required
~600W	1 unit	1 unit	1 unit
~800W	1 unit	2 units	1 unit
~1200W	2 units	-	2 units
~1600W	3 units	-	Consult IAI.
~2000W	4 units	-	-
~2400W	5 units	-	-

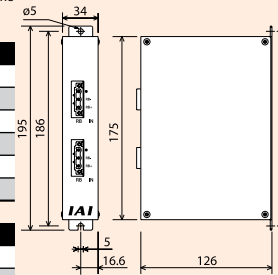

Absolute-data Backup Battery (for XSEL-J/K/KE/KT/KET)

Model **IA-XAB-BT**

**Features** A data backup battery for absolute axes. Replace the battery as soon as the controller generates a battery alarm.

Packing specification

Individually packed. (One battery is required for one axis. Specify an appropriate quantity according to the number of axes to be used.)



Expansion SIO Board (for General-purpose Type Only)

Model Specification

IA-105-X-MW-A (for RS232C connection) (board + joint cable [1] x 2)  
 IA-105-X-MW-B (for RS422 connection) (board + joint cable [2] x 1)  
 IA-105-X-MW-C (for RS485 connection) (board + joint cable [2] x 1)

Description

This board is used to perform serial communication with external devices. The 2-channel port supports three communication patterns according to the supplied joint cable.

Joint cable [1] / Model: CB-ST-232J001

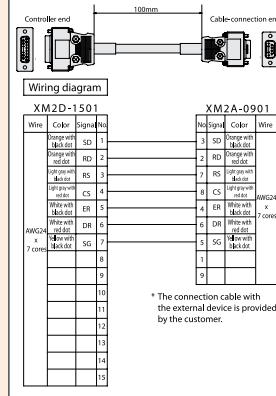

Joint cable [2] / Model: CB-ST-422J010

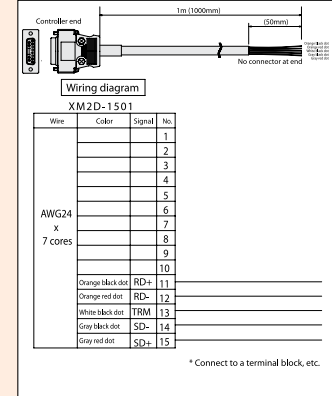

Absolute-data Backup Battery

Model **AB-5**

**Features** This absolute-data backup battery is used when absolute actuators are operated.



Expansion PIO Board

Description

This optional board is used to add I/Os (inputs/outputs). On the general-purpose and large-capacity types, up to three expansion PIO boards can be installed in the expansion slots. (On the small type, only one expansion PIO board can be installed in the expansion slot, provided that the controller is of 3 or 4-axis type.)

DeviceNet Connection Board

This board is used to connect the XSEL controller to DeviceNet.

Item	Specification			
Number of I/O points	256 input points/256 output points per board * Only one board can be installed.			
Communication protocol	Certified DeviceNet 2.0 interface module (Certification pending)			
	Group 2 only server			
Communication specification	Insulation node of network-power operation type			
	Master-slave connection	Bit strobe		
		Polling		
Cyclic				
Baud rate	500k/250k/125kbps (Switchable via DIP switches)			
Communication cable length	Baud rate	Maximum network length	Maximum branch length	Total branch length
	500kbps	100m	6m	39m
	250kbps	250m		78m
	125kbps	500m		156m
Note) When a thick DeviceNet cable is used.				
Communication power supply	24 VDC (supplied from DeviceNet)			
Current consumption of communication power supply	60 mA or more			
Number of occupied stations	1 node			
Connector	MSTBA2.5/5-G.08AUM by Phoenix Contact (*1)			

(\*1) The cable-end connector (SMSTB2.5/5-ST-5.08AU by Phoenix Contact) is a standard accessory.

CC-Link Connection Board

This board is used to connect the XSEL controller to CC-Link.

Item	Specification					
Number of I/O points	256 input points/256 output points per board * Only one board can be installed.					
Communication protocol	CC-Link Ver.1.10 (Certified)					
Baud rate	10M/5M/2.5M/625k/156kbps (switchable via a rotary switch)					
Communication method	Broadcast polling method					
Synchronization method	Frame synchronization method					
Encoding method	NRZI					
Transmission path format	Bus format (conforming to EIA RS485)					
Transmission format	Conforming to HDLC					
Error control method	CRC(X <sup>16</sup> +X <sup>12</sup> +X <sup>5</sup> +1)					
Number of occupied stations	1 to 3 stations (remote device stations)					
Communication cable length	Baud rate (bps)	10M	5M	2.5M	625k	156k
	Cable length (m)	100	160	400	900	1200
Connector (controller end)	MSTBA2.5/5-G.08AUM by Phoenix Contact (*1)					

(\*1) The cable-end connector (SMSTB2.5/5-ST-5.08AU by Phoenix Contact) is a standard accessory.

2-axis Combinations R C P 2

2-axis Combinations R C S 2

3-axis Combinations R C P 2

3-axis Combinations R C S 2

Controllers

Model List

PSEL SSEL

ROBONET XSEL

## Options

### Teaching Pendant

**Features** A teaching device offering functions for program/position input, test operation, monitoring, and more.

**Model/Price**

Model	Description
SEL-T	Standard type with connector conversion cable
SEL-TD	Deadman switch type with connector conversion cable

**Configuration**

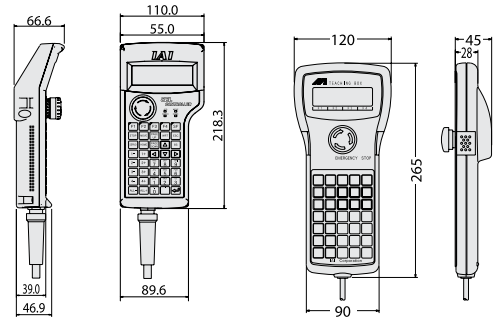
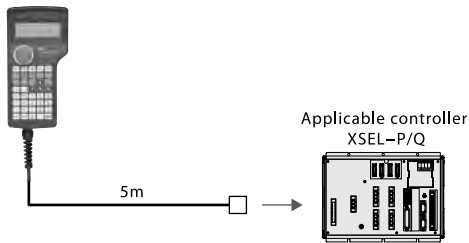

**Specification**

Item	SEL-T-J	SEL-TD-J
3-position enable switch	Not equipped	Equipped
ANSI/UL standard	Not compliant	Compliant
CE mark	Compliant	
Display	20 characters x 4 lines	
Surrounding air temperature/humidity	0-40°C 10-90%RH (non-condensing)	
Protection structure	IP54	
Weight	Approx. 0.4 kg (excluding cables)	

### PC Software (Windows only)

**Features** A software program that assists the initial startup of your system, offering functions for program/position input, test operation, monitoring, and more. The enhanced debugging functions help reduce the startup time.

**Model IA-101-X-MW** (with RS232C cable)

**Configuration**

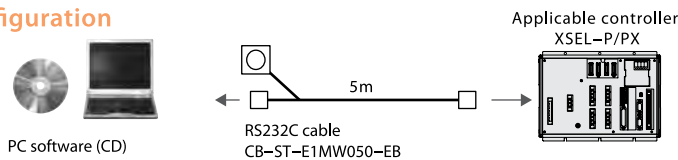

**Model IA-101-XA-MW** (with safety category 4 cable)

**Configuration**

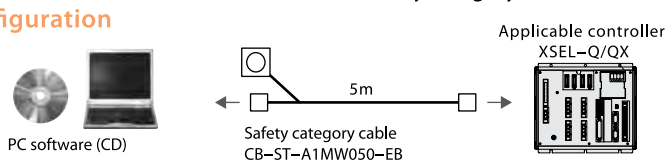

**Model IA-101-X-USBMW** (with USB conversion adapter + cable)

**Configuration**

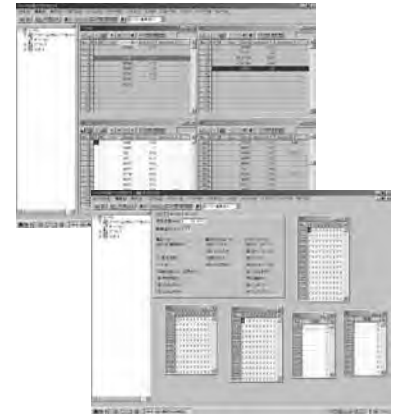
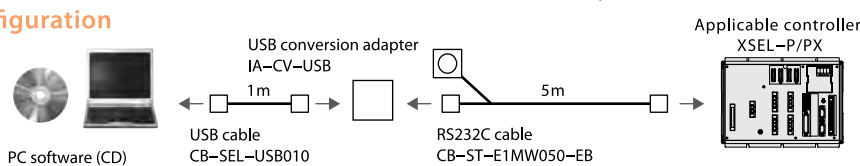

### Replacement Parts

If you must order a replacement cable, etc., after the initial purchase of your product, specify the correct model by referring to the information below.

#### Motor Cable/Robot Motor Cable

Item **CB-RCC-MA** / **CB-RCC-MA**-RB

\* [ ] indicates the cable length (L). A desired length up to 20 m can be specified. Example) 080 = 8 m

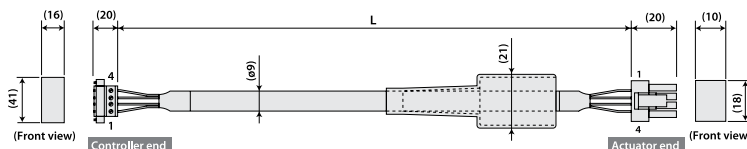

Signal	No.	No.	Signal	Wire
PE	1	1	U	0.75sq (crimped)
U	2	2	V	
V	3	3	W	
W	4	4	PE	

Replacement Parts

Encoder Cable/Robot Encoder Cable (for XSEL-J/K types)

Item **CB-RCBC-PA** [ ] [ ] [ ] / **CB-RCBC-PA** [ ] [ ] [ ] -**RB**

\* [ ] [ ] [ ] indicates the cable length (L). A desired length up to 15 m can be specified. Example) 080 = 8 m

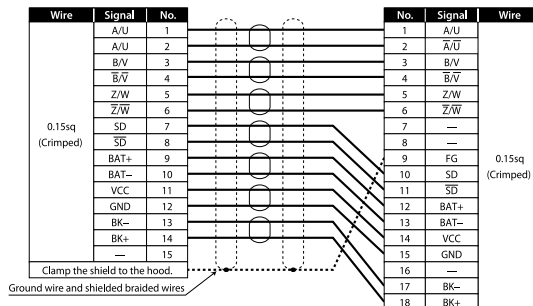
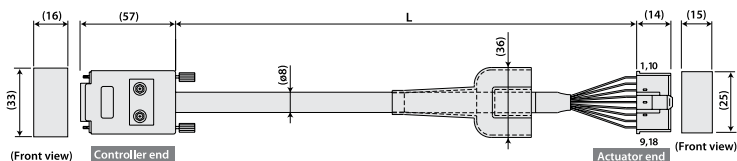

Encoder Cable/Robot Encoder Cable (for XSEL-P/Q types)

Item **CB-RCS2-PA** [ ] [ ] [ ] / **CB-X3-PA** [ ] [ ] [ ]

\* [ ] [ ] [ ] indicates the cable length (L). A desired length up to 20 m can be specified. Example) 080 = 8 m

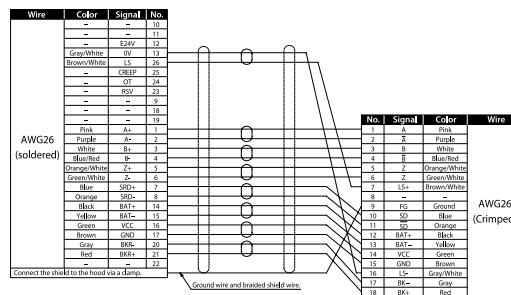
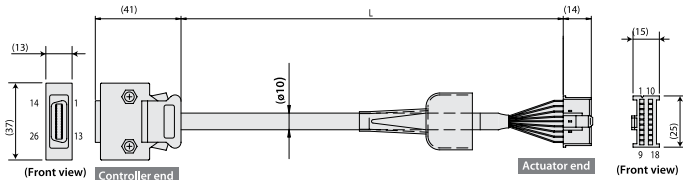

Dedicated Encoder Cable/Robot Encoder Cable for Rotary Robots

Item **CB-RCS2-PLA** [ ] [ ] [ ] / **CB-X2-PLA** [ ] [ ] [ ]

\* [ ] [ ] [ ] indicates the cable length (L). A desired length up to 30 m can be specified. Example) 080 = 8 m

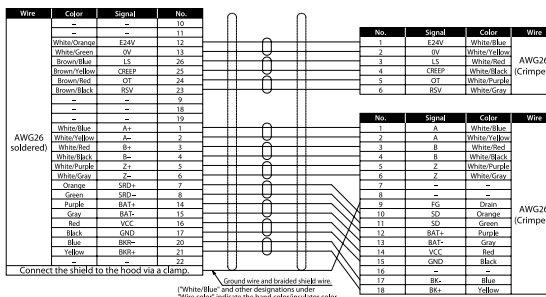
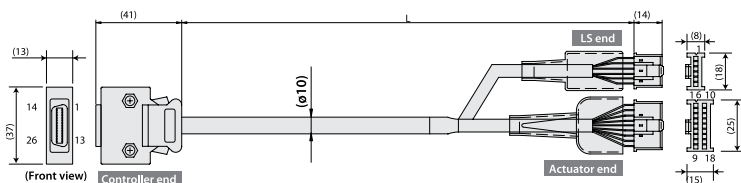

Limit Switch Cable (for X-SEL-J/K types)

Item **CB-X-LC** [ ] [ ] [ ]

\* [ ] [ ] [ ] indicates the cable length (L). A desired length up to 20 m can be specified. Example) 080 = 8 m

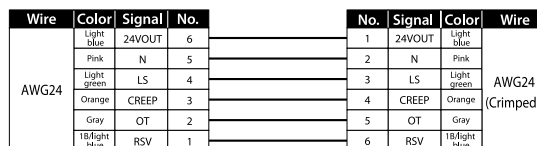
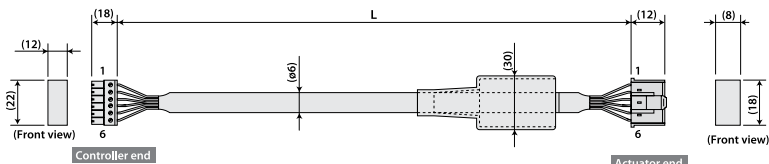

Note) \*1B\* indicates one black dot.

I/O Flat Cable (XSEL-J/K/P/Q types)

Item **CB-X-PIO** [ ] [ ] [ ]

\* [ ] [ ] [ ] indicates the cable length (L). A desired length up to 10 m can be specified. Example) 080 = 8 m

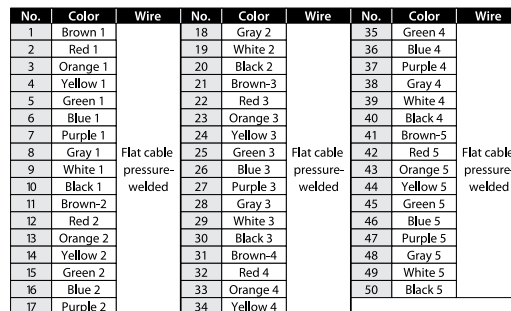
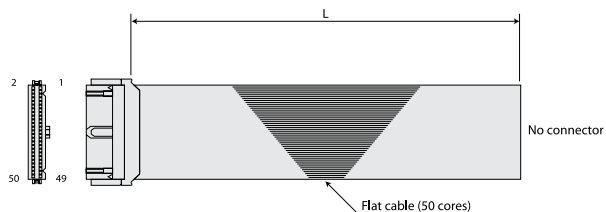



## [A]

AB-5	(System-memory backup battery)	101 • 111
AB-5	(Absolute-data backup battery)	111 • 132
AB-5-CS	(System-memory backup battery)	101 • 111

## [C]

CB-ACS-MA□□□□	(•able)	124
CB-ACS-MPA□□□□	(Cable)	124
CB-ACS-PA□□□□	(Cable)	124
CB-ACS-PA□□□□-RB	(Cable)	124
CB-DS-PIO□□□□	(Cable)	102 • 112
CB-PCS-MPA□□□□	(Cable)	102 • 123
CB-RCBC-PA□□□□	(Cable)	134
CB-RCBC-PA□□□□-RB	(Cable)	134
CB-RCC-MA□□□□	(Cable)	112 • 133
CB-RCC-MA□□□□-RB	(Cable)	112 • 133
CB-RCP2-MA□□□□	(Cable)	102 • 123
CB-RCP2-PB□□□□	(Cable)	123
CB-RCP2-PB□□□□-RB	(Cable)	123
CB-RCP2-PB□□□□	(Cable)	102
CB-RCP2-PB□□□□-RB	(Cable)	102
CB-RCS2-PA□□□□	(Cable)	112
CB-RCS2-PA□□□□	(Cable)	134
CB-RCS2-PLA□□□□	(Cable)	112 • 134
CB-REXT-CTL010	(Cable)	124
CB-REXT-SIO010	(Cable)	124
CB-SEL-SJ002	(Cable)	102 • 112
CB-SEL-USB010	(Cable)	102 • 112
CB-X2-PLA□□□□	(Cable)	112 • 134
CB-X3-PA□□□□	(Cable)	112 • 134
CB-X-LC□□□□	(Cable)	134
CB-X-PIO□□□□	(Cable)	134
CON-T	(Teaching pendant)	122

## [D]

DP-3	(Dummy plug)	101 • 112
------	--------------	-----------

## [I]

IA-101-XA-MW	(PC software)	133
IA-101-X-MW	(PC software)	111 • 133
IA-101-X-MW-J	(PC software)	101 • 111
IA-101-X-USB	(PC software)	101 • 111
IA-101-X-USBMW	(PC software)	133
IA-105-X-MW-A	(Expansion SIO board)	132
IA-105-X-MW-B	(Expansion SIO board)	132
IA-105-X-MW-C	(Expansion SIO board)	132
IA-XAB-BT	(Absolute-data backup battery)	132
IK2-PXBB1□□D	(IA kit)	31
IK2-PXBB1□□S	(IA kit)	29
IK2-PXBB2□□D	(IA kit)	35
IK2-PXBB2□□S	(IA kit)	33
IK2-PXBC1□□D	(IA kit)	23
IK2-PXBC1□□S	(IA kit)	21
IK2-PXBC2□□D	(IA kit)	27
IK2-PXBC2□□S	(IA kit)	25
IK2-PXBD1□□D	(IA kit)	15
IK2-PXBD1□□S	(IA kit)	13
IK2-PXBD2□□D	(IA kit)	19
IK2-PXBD2□□S	(IA kit)	17
IK2-PXZB1□□D	(IA kit)	39
IK2-PXZB1□□S	(IA kit)	37
IK2-PYBB1□□S	(IA kit)	41
IK2-SXBA1□□D	(IA kit)	69

IK2-SXBA1□□S	(IA kit)	67
IK2-SXBA2□□D	(IA kit)	73
IK2-SXBA2□□S	(IA kit)	71
IK2-SXBB1□□D	(IA kit)	61
IK2-SXBB1□□S	(IA kit)	59
IK2-SXBB2□□D	(IA kit)	65
IK2-SXBB2□□S	(IA kit)	63
IK2-SXBC1□□D	(IA kit)	53
IK2-SXBC1□□S	(IA kit)	51
IK2-SXBC2□□D	(IA kit)	57
IK2-SXBC2□□S	(IA kit)	55
IK2-SXBD1□□D	(IA kit)	45
IK2-SXBD1□□S	(IA kit)	43
IK2-SXBD2□□D	(IA kit)	49
IK2-SXBD2□□S	(IA kit)	47
IK2-SXZB1□□D	(IA kit)	77
IK2-SXZB1□□S	(IA kit)	75
IK2-SYBB1□□S	(IA kit)	79
IK3-PBBG1□□D	(IA kit)	83
IK3-PBBG1□□S	(IA kit)	81
IK3-SBBG1□□D	(IA kit)	88
IK3-SBBG1□□S	(IA kit)	85

## [J]

JB-1	(ROBONET communication connection board)	123
------	--	-----

## [P]

PP-1	(Power-supply connection plate)	123
PS-241	(24-V power supply)	123
PS-242	(24-V power supply)	123
PSEL-C	(Controller)	93
PU-1	(Panel unit)	101 • 111

## [R]

RABU	(Simple absolute R unit)	121
RACON	(RACON unit)	120
RCM-101-MW	(PC software)	122
RCM-101-USB	(PC software)	122
RCM-E	(Teaching pendant)	122
RCM-P	(Teaching pendant)	122
REU-1	(Regenerative resistor unit)	132
REU-2	(Regenerative resistor unit)	111
REXT	(Expansion unit)	121
RGW-CC	(Gateway R unit)	118
RGW-DV	(Gateway R unit)	118
RGW-PR	(Gateway R unit)	119
RGW-SIO	(Gateway R unit)	119
ROBONET	(Controller)	113
RPCON	(RPCON unit)	120

## [S]

SEL-T	(Teaching pendant)	133
SEL-TD	(Teaching pendant)	133
SEL-TD-J	(Teaching pendant)	10 • 11
SEL-T-J	(Teaching pendant)	10 • 11
SSEL-C	(Controller)	103

## [T]

TN-1	(Terminal resistor board)	123
------	---------------------------	-----

## [X]

XSEL-J	(Controller)	125
XSEL-K	(Controller)	125
XSEL-P	(Controller)	125
XSEL-Q	(Controller)	125





---

**IAI America, Inc.**

**Headquarters:** 2690 W. 237th Street Torrance, CA 90505 (800) 736-1712

**Chicago Office:** 1261 Hamilton Parkway Itasca, IL 60143 (800) 944-0333

**Atlanta Office:** 1220 Kennestone Circle, Suite 108, Marietta, GA 30066 (888) 354-9470

The information contained in this product brochure may change without prior notice due to product improvements.

**IAI Industrieroboter GmbH**

Ober der Roth 4, D-65824 Schwalbach am Taunus, Germany

**[www.intelligentactuator.com](http://www.intelligentactuator.com)**

