

**CURTISS -
WRIGHT**

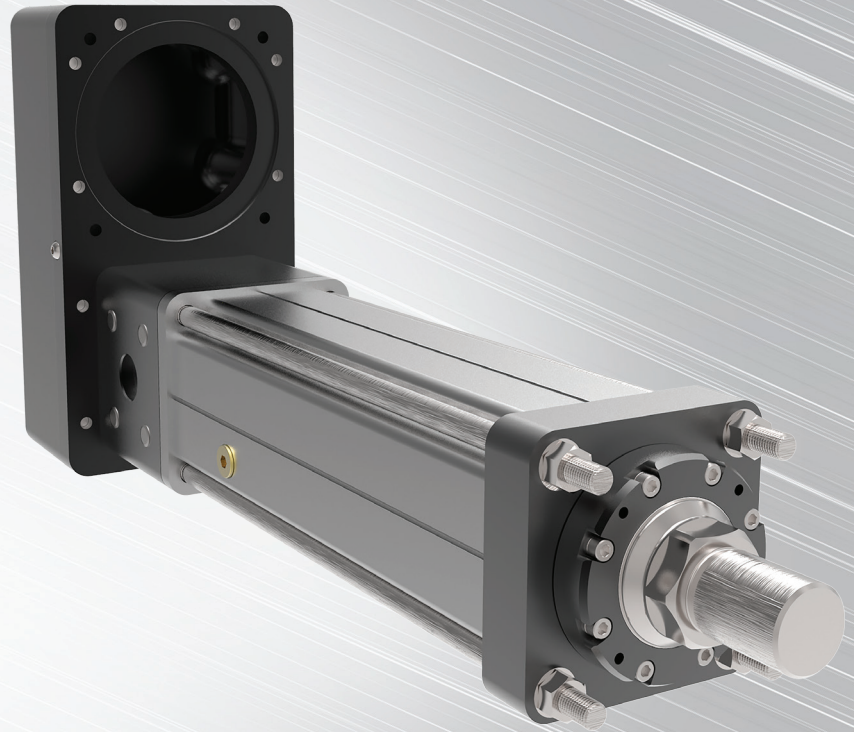

FTX Series Product Catalog



FTX Series

HIGH FORCE ACTUATOR

Hydraulic cylinder replacement

Rugged and reliable

Powerful and compact

Clean and efficient

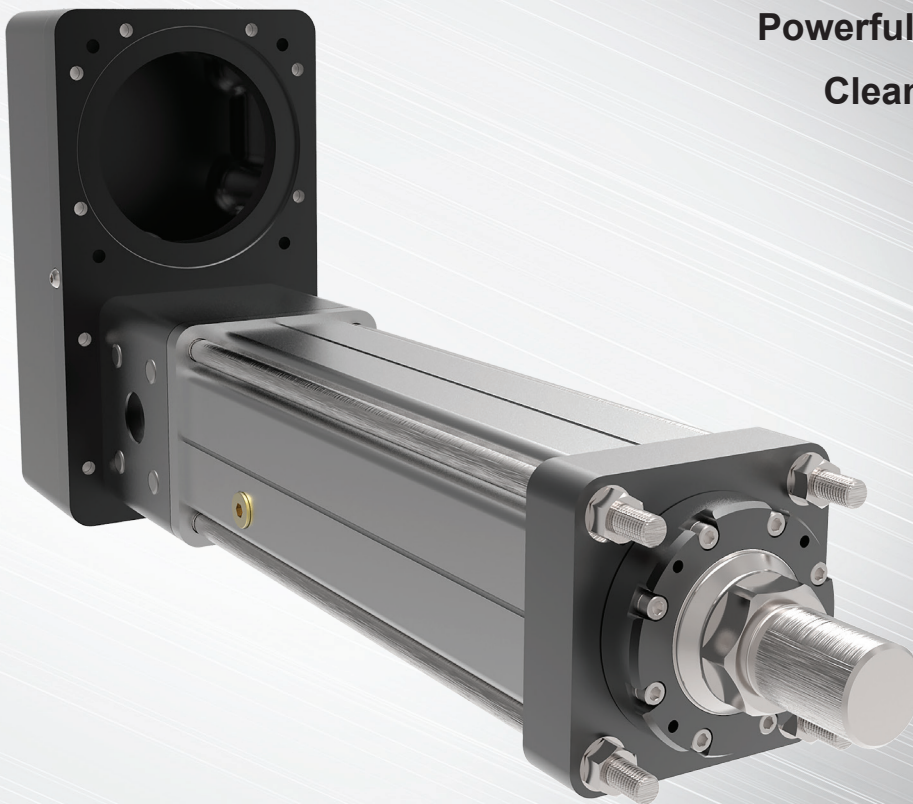

FTX Series

High Force Actuators

Hydraulic Cylinder Replacement

Hydraulic cylinders provide long life and high force in a small package size. The FTX Series high force electric actuators were designed specifically to allow migration from traditional hydraulic actuation to electric. Based on planetary roller screw technology, the FTX offers life and force density not attainable with more common ball screw based electric actuators. With up to 15X the life and 2X the force density, the roller screw based FTX is the right choice when migrating from hydraulic to electric actuation.

Rugged and Reliable

Hydraulic cylinders are commonly installed in harsh industrial settings. Therefore all FTX Series models are environmentally sealed to IP65S. In addition, its planetary roller screw mechanism withstands significantly higher shock loads than weaker ball screw alternatives. Migrate to electric with confidence knowing the FTX Series is every bit as rugged and reliable as the hydraulics they are designed to replace.

Minimal Maintenance

More and more machine builders are looking to eliminate the mess and downtime associated with hydraulic fluid leaks. Electric actuation not only eliminates the problems associated with fluid leaks, it offers significantly higher levels of performance and flexibility than is possible even with servo-hydraulic solutions. FTX Series roller screw actuators allow machine builders to meet the ever-increasing performance demands of their customers while minimizing or eliminating the maintenance issues associated with traditional hydraulic solutions.

Operating Conditions and Usage		
Accuracy:		
Screw Travel Variation	mm (in)	0.030 (0.0012)
Screw Lead Error	mm/300 mm (in/ft)	0.025 (0.001)
Screw Lead Backlash	mm (in)	0.06 (0.002)
Ambient Conditions:		
Standard Ambient Temperature	°C	0° to 85°
Low Temperature Grease Option		-40°
IP Rating		IP65S

Product Features

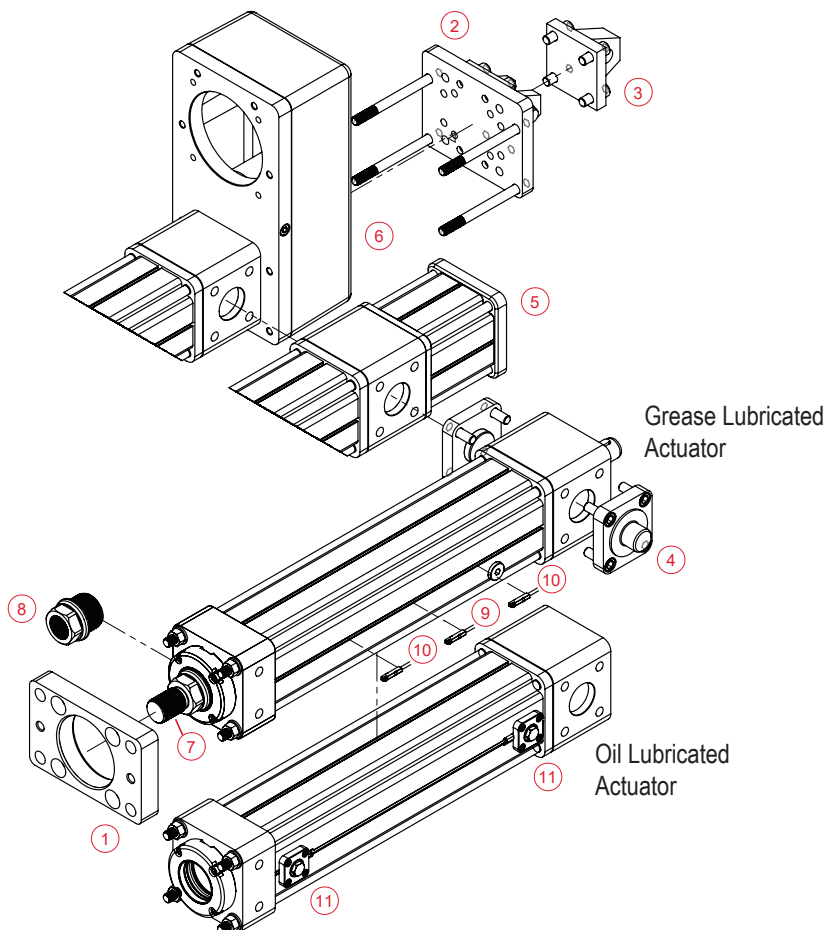
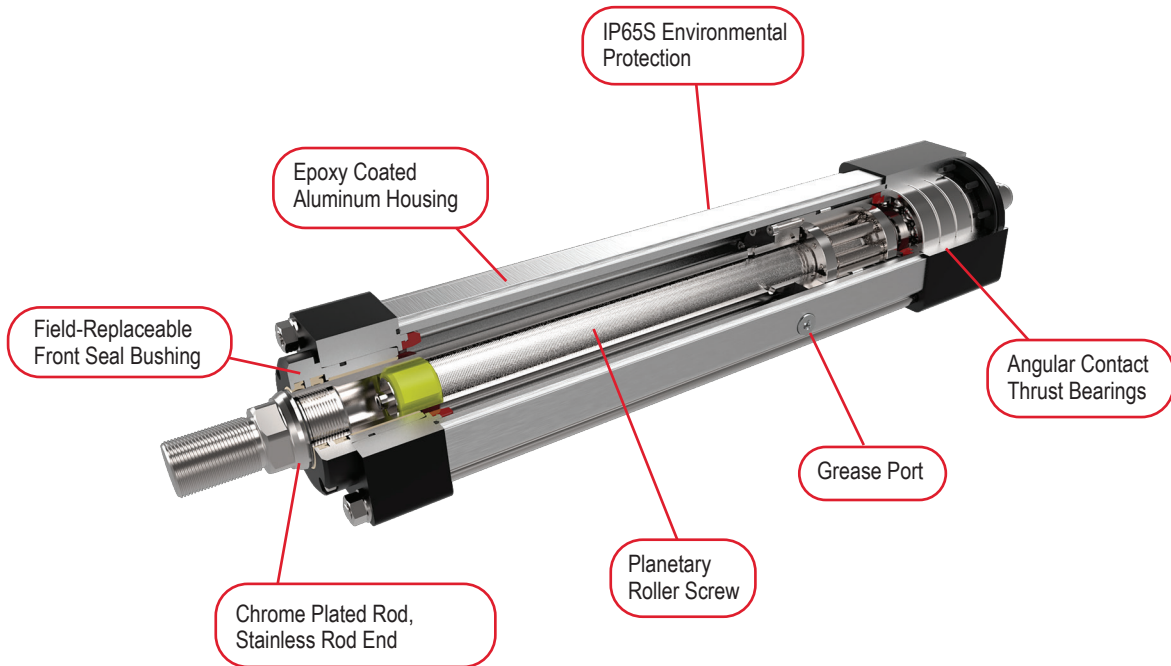

- 1 - Front flange
- 2 - Rear clevis
- 3 - Rear eye
- 4 - Rear trunnion
- 5 - Inline direct drive
- 6 - Parallel, 1:1 belt reduction
Parallel, 2:1 belt reduction
- 7 - Male, metric thread
- 8 - Female, metric thread
- 9 - External limit switch - N.O., PNP or NPN*
- 10 - External limit switch - N.C., PNP or NPN*
- 11 - Oil ports

*Ordered Separately

Mechanical Specifications

FTX095

		05	10	20
Screw Lead	mm	5	10	20
	in	0.197	0.394	0.787
Maximum Force	kN	22.2	22.2	22.2
	lbf	5,000	5,000	5,000
Life at Maximum Force	km	392	626	1440
	in x 10 ⁶	15.4	24.6	56.7
C _s (Dynamic Load Rating)	kN	95.2	88.3	92.5
	lbf	21,400	19,850	20,800
Maximum Input Torque	Nm	22.1	44.3	88.5
	lbf-in	196	392	783
Max Rated RPM @ Input Shaft	RPM	4,500	4,500	4,500
Maximum Linear Speed @ Maximum Rated RPM	mm/sec	373	750	1,500
	in/sec	14.7	29.5	59.3
Friction Torque (Typical)	Nm	1.12	1.12	1.12
	lbf-in	10	10	10

Weights kg (lbs)

Base Actuator Weight (Zero Stroke)	kg	10
	lb	21
Actuator Weight Adder (Per 25 mm of stroke)	kg	0.39
	lb	0.87
Adder for Inline (excluding motor)	kg	2.9
	lb	6.5
Adder for Parallel Drive (excluding motor)	kg	13.1
	lb	28.9
Adder for Front Flange	kg	1.9
	lb	4.2
Adder for Rear Clevis	kg	5.3
	lb	11.7
Adder for Rear Eye	kg	5.1
	lb	11.3
Adder for Rear Trunnion	kg	1.9
	lb	4.3

Base Unit Inertia		Zero Stroke [kg-m ² (lbf-in-sec ²)]	Add per 25 mm [kg-m ² (lbf-in-sec ²)]
5 mm Lead		8.27 x 10 ⁻⁴ (7.32 x 10 ⁻³)	2.19 x 10 ⁻⁶ (1.94 x 10 ⁻⁵)
10 mm Lead		8.33 x 10 ⁻⁴ (7.37 x 10 ⁻³)	2.42 x 10 ⁻⁶ (2.14 x 10 ⁻⁵)
20 mm Lead		8.57 x 10 ⁻⁴ (7.58 x 10 ⁻³)	3.31 x 10 ⁻⁶ (2.93 x 10 ⁻⁵)
Inline Drive Inertia	Inline Unit - w/Motor Coupling	Inline Unit - w/Motor Coupling For Gearbox Mount	Add per 25 mm
5 mm Lead	9.27 x 10 ⁻⁴ (8.20 x 10 ⁻³)	1.09 x 10 ⁻³ (9.62 x 10 ⁻³)	2.19 x 10 ⁻⁶ (1.94 x 10 ⁻⁵)
10 mm Lead	9.33 x 10 ⁻⁴ (8.26 x 10 ⁻³)	1.09 x 10 ⁻³ (9.67 x 10 ⁻³)	2.42 x 10 ⁻⁶ (2.14 x 10 ⁻⁵)
20 mm Lead	9.57 x 10 ⁻⁴ (8.47 x 10 ⁻³)	1.12 x 10 ⁻³ (9.89 x 10 ⁻³)	3.31 x 10 ⁻⁶ (2.93 x 10 ⁻⁵)
Parallel Drive Inertia		1:1 Reduction	2:1 Reduction
5 mm Lead (zero stroke)		4.90 x 10 ⁻³ (4.34 x 10 ⁻²)	2.22 x 10 ⁻³ (1.97 x 10 ⁻²)
Add per 25 mm stroke		2.19 x 10 ⁻⁶ (1.94 x 10 ⁻⁵)	5.48 x 10 ⁻⁷ (4.85 x 10 ⁻⁶)
10 mm Lead (zero stroke)		4.91 x 10 ⁻³ (4.34 x 10 ⁻²)	2.23 x 10 ⁻³ (1.97 x 10 ⁻²)
Add per 25 mm stroke		2.42 x 10 ⁻⁶ (2.14 x 10 ⁻⁵)	6.04 x 10 ⁻⁷ (5.34 x 10 ⁻⁶)
20 mm Lead (zero stroke)		4.93 x 10 ⁻³ (4.37 x 10 ⁻²)	2.23 x 10 ⁻³ (1.98 x 10 ⁻²)
Add per 25 mm stroke		3.31 x 10 ⁻⁶ (2.93 x 10 ⁻⁵)	8.28 x 10 ⁻⁷ (7.33 x 10 ⁻⁶)

FTX125

		05	10
Screw Lead	mm	5	10
	in	0.197	0.394
Maximum Force	kN	44.5	44.5
	lbf	10,000	10,000
Life at Maximum Force	km	249.2	486.3
	in x 10 ⁶	9.81	19.14
C _a (Dynamic Load Rating)	kN	163.7	162.4
	lbf	36,800	36,500
Maximum Input Torque	Nm	46.5	82.3
	lbf-in	412	728
Max Rated RPM @ Input Shaft	RPM	3,500	3,500
Maximum Linear Speed @ Maximum Rated RPM	mm/sec	292	583
	in/sec	11.5	23
Friction Torque (Typical)	Nm	2.23	2.23
	lbf-in	20	20

Weights kg (lbs)

Base Actuator Weight (Zero Stroke)	kg	21
	lb	47
Actuator Weight Adder (Per 25 mm of stroke)	kg	0.84
	lb	1.85
Adder for Inline (excluding motor)	kg	6.8
	lb	15.0
Adder for Parallel Drive (excluding motor)	kg	25.6
	lb	56.5
Adder for Front Flange	kg	3.6
	lb	7.9
Adder for Rear Clevis	kg	6.5
	lb	14.3
Adder for Rear Eye	kg	6.3
	lb	13.8
Adder for Rear Trunnion	kg	3.1
	lb	6.8

Base Unit Inertia		Zero Stroke [kg-m ² (lbf-in-sec ²)]	Add per 25 mm [kg-m ² (lbf-in-sec ²)]
5 mm Lead		2.55 x 10 ⁻³ (2.26 x 10 ⁻²)	4.62 x 10 ⁻⁵ (4.09 x 10 ⁻⁴)
10 mm Lead		2.56 x 10 ⁻³ (2.27 x 10 ⁻²)	4.65 x 10 ⁻⁵ (4.12 x 10 ⁻⁴)
Inline Drive Inertia	<32 mm Motor Shaft Diameter	>32 mm Motor Shaft Diameter	Add per 25 mm
5 mm Lead	2.81 x 10 ⁻³ (2.49 x 10 ⁻²)	3.35 x 10 ⁻³ (2.97 x 10 ⁻²)	4.62 x 10 ⁻⁵ (4.09 x 10 ⁻⁴)
10 mm Lead	2.82 x 10 ⁻³ (2.50 x 10 ⁻²)	3.36 x 10 ⁻³ (2.98 x 10 ⁻²)	4.65 x 10 ⁻⁵ (4.12 x 10 ⁻⁴)
Parallel Drive Inertia		1:1 Reduction	2:1 Reduction
5 mm Lead (zero stroke)		9.43 x 10 ⁻³ (8.34 x 10 ⁻²)	4.66 x 10 ⁻³ (4.12 x 10 ⁻²)
Add per 25 mm stroke		4.62 x 10 ⁻⁵ (4.09 x 10 ⁻⁴)	1.15 x 10 ⁻⁵ (1.02 x 10 ⁻⁴)
10 mm Lead (zero stroke)		9.44 x 10 ⁻³ (8.35 x 10 ⁻²)	4.66 x 10 ⁻³ (4.13 x 10 ⁻²)
Add per 25 mm stroke		4.65 x 10 ⁻⁵ (4.12 x 10 ⁻⁴)	1.16 x 10 ⁻⁵ (1.03 x 10 ⁻⁴)

FTX160

		06	12	30
Screw Lead	mm	6	12	30
	in	0.236	0.472	1.181
Maximum Force	kN	89.0	89.0	89.0
	lbf	20,000	20,000	20,000
Life at Maximum Force	km	154.9	416.6	358.9
	in x 10 ⁶	6.1	16.4	21.2
C _a (Dynamic Load Rating)	kN	263.7	290.0	233.0
	lbf	59,275	65,200	52,400
Maximum Input Torque	Nm	106	212	531
	lbf-in	940	1,880	4,699
Max Rated RPM @ Input Shaft	RPM	2,000	2,000	2,000
Maximum Linear Speed @ Maximum Rated RPM	mm/sec	201	401	1000
	in/sec	7.9	15.8	39.0
Friction Torque (Typical)	Nm	4.54	4.54	4.54
	lbf-in	40	40	40

Weights kg (lbs)

Base Actuator Weight (Zero Stroke)	kg	49
	lb	108
Actuator Weight Adder (Per 25 mm of stroke)	kg	1.62
	lb	3.6
Adder for Inline (excluding motor)	kg	14.2
	lb	31.5
Adder for Parallel Drive (excluding motor)	kg	53.1
	lb	117.8
Adder for Front Flange	kg	7.4
	lb	16.4
Adder for Rear Clevis	kg	21.2
	lb	48.8
Adder for Rear Eye	kg	22.4
	lb	49.7
Adder for Rear Trunnion	kg	10.9
	lb	24.2

Base Unit Inertia		Zero Stroke [kg-m ² (lbf-in-sec ²)]	Add per 25 mm [kg-m ² (lbf-in-sec ²)]
6 mm Lead		1.35 x 10 ⁻² (1.19 x 10 ⁻¹)	2.57 x 10 ⁻⁴ (2.27 x 10 ⁻³)
12 mm Lead		1.35 x 10 ⁻² (1.20 x 10 ⁻¹)	2.58 x 10 ⁻⁴ (2.28 x 10 ⁻³)
30 mm Lead		1.38 x 10 ⁻² (1.22 x 10 ⁻¹)	2.66 x 10 ⁻⁴ (2.36 x 10 ⁻³)
Inline Drive Inertia	<32 mm Motor Shaft Diameter	>32 mm Motor Shaft Diameter	Add per 25 mm
6 mm Lead		1.47 x 10 ⁻² (1.30 x 10 ⁻¹)	2.57 x 10 ⁻⁴ (2.27 x 10 ⁻³)
12 mm Lead		1.47 x 10 ⁻² (1.30 x 10 ⁻¹)	2.58 x 10 ⁻⁴ (2.28 x 10 ⁻³)
30 mm Lead		1.50 x 10 ⁻² (1.33 x 10 ⁻¹)	2.66 x 10 ⁻⁴ (2.36 x 10 ⁻³)
Parallel Drive Inertia		1:1 Reduction	2:1 Reduction
6 mm Lead (zero stroke)		5.27 x 10 ⁻² (4.67 x 10 ⁻¹)	2.30 x 10 ⁻² (2.04 x 10 ⁻¹)
Add per 25 mm stroke		2.57 x 10 ⁻⁴ (2.27 x 10 ⁻³)	6.42 x 10 ⁻⁵ (5.68 x 10 ⁻⁴)
12 mm Lead (zero stroke)		5.28 x 10 ⁻² (4.67 x 10 ⁻¹)	2.30 x 10 ⁻² (2.04 x 10 ⁻¹)
Add per 25 mm stroke		2.58 x 10 ⁻⁴ (2.28 x 10 ⁻³)	6.45 x 10 ⁻⁵ (5.71 x 10 ⁻⁴)
30 mm Lead (zero stroke)		5.30 x 10 ⁻² (4.69 x 10 ⁻¹)	2.31 x 10 ⁻² (2.05 x 10 ⁻¹)
Add per 25 mm stroke		2.66 x 10 ⁻⁴ (2.36 x 10 ⁻³)	6.66 x 10 ⁻⁵ (5.89 x 10 ⁻⁴)

FTX215

		06	12	30
Screw Lead	mm	6	12	30
	in	0.236	0.472	1.181
Maximum Force	kN	177.9	177.9	177.9
	lbf	40,000	40,000	40,000
Life at Maximum Force	km	78.7	161.8	414.3
	in x 10 ⁶	3.1	6.4	16.3
C _a (Dynamic Load Rating)	kN	398	423	376
	lbf	89,500	95,200	84,700
Maximum Input Torque	Nm	243	425	976
	lbf-in	2,148	3,760	8,642
Max Rated RPM @ Input Shaft	RPM	1,750	1,750	1,750
Maximum Linear Speed @ Maximum Rated RPM	mm/sec	175	351	875
	in/sec	6.9	13.8	34.4
Friction Torque (Typical)	Nm	5.65	5.65	5.65
	lbf-in	50	50	50

Weights kg (lbs)

Base Actuator Weight (Zero Stroke)	kg	103
	lb	227
Actuator Weight Adder (Per 25 mm of stroke)	kg	2.70
	lb	5.96
Adder for Inline (excluding motor)	kg	38.6
	lb	85.1
Adder for Parallel Drive (excluding motor)	kg	62.3
	lb	137.3
Adder for Front Flange	kg	26.7
	lb	58.8
Adder for Rear Clevis	kg	32.5
	lb	71.6
Adder for Rear Eye	kg	32.5
	lb	71.6
Adder for Rear Trunnion	kg	9.6
	lb	21.2

Base Unit Inertia		Zero Stroke [kg-m ² (lbf-in-sec ²)]	Add per 25 mm [kg-m ² (lbf-in-sec ²)]	
6 mm Lead		4.25 x 10 ⁻² (3.76 x 10 ⁻¹)	8.00 x 10 ⁻⁴ (7.08 x 10 ⁻³)	
12 mm Lead		4.26 x 10 ⁻² (3.77 x 10 ⁻¹)	8.02 x 10 ⁻⁴ (7.10 x 10 ⁻³)	
30 mm Lead		4.31 x 10 ⁻² (3.82 x 10 ⁻¹)	8.15 x 10 ⁻⁴ (7.21 x 10 ⁻³)	
Inline Drive Inertia	<55 mm Motor Shaft Diameter	>55 mm Motor Shaft Diameter	Add per 25 mm	
6 mm Lead		4.43 x 10 ⁻² (3.92 x 10 ⁻¹)	6.15 x 10 ⁻² (5.44 x 10 ⁻¹)	8.00 x 10 ⁻⁴ (7.08 x 10 ⁻³)
12 mm Lead		4.44 x 10 ⁻² (3.93 x 10 ⁻¹)	6.16 x 10 ⁻² (5.45 x 10 ⁻¹)	8.02 x 10 ⁻⁴ (7.10 x 10 ⁻³)
30 mm Lead		4.49 x 10 ⁻² (3.98 x 10 ⁻¹)	6.21 x 10 ⁻² (5.50 x 10 ⁻¹)	8.15 x 10 ⁻⁴ (7.21 x 10 ⁻³)
Parallel Drive Inertia	1:1 Reduction		2:1 Reduction	
6 mm Lead (zero stroke)		9.42 x 10 ⁻² (8.34 x 10 ⁻¹)	3.50 x 10 ⁻² (3.10 x 10 ⁻¹)	
Add per 25 mm stroke		8.00 x 10 ⁻⁴ (7.08 x 10 ⁻³)	2.00 x 10 ⁻⁴ (1.77 x 10 ⁻³)	
12 mm Lead (zero stroke)		9.43 x 10 ⁻² (8.34 x 10 ⁻¹)	3.50 x 10 ⁻² (3.10 x 10 ⁻¹)	
Add per 25 mm stroke		8.02 x 10 ⁻⁴ (7.10 x 10 ⁻³)	2.01 x 10 ⁻⁴ (1.78 x 10 ⁻³)	
30 mm Lead (zero stroke)		9.48 x 10 ⁻² (8.39 x 10 ⁻¹)	3.52 x 10 ⁻² (3.11 x 10 ⁻¹)	
Add per 25 mm stroke		8.15 x 10 ⁻⁴ (7.21 x 10 ⁻³)	2.04 x 10 ⁻⁴ (1.80 x 10 ⁻³)	

Estimated Service Life

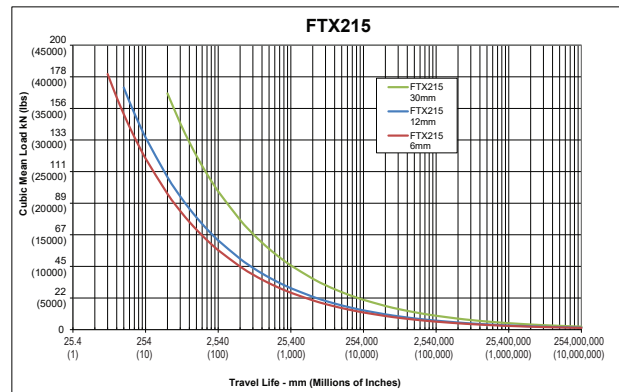
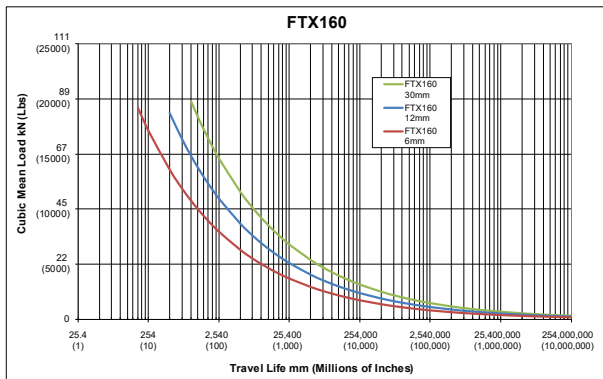
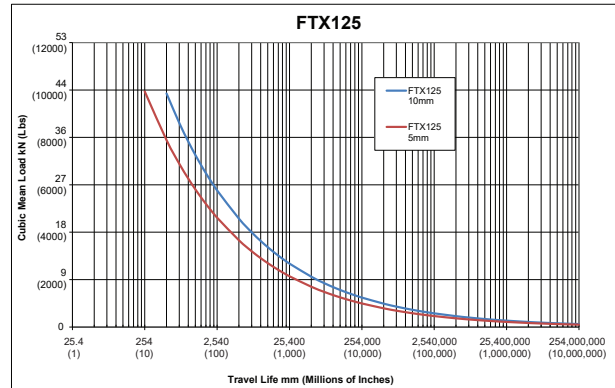
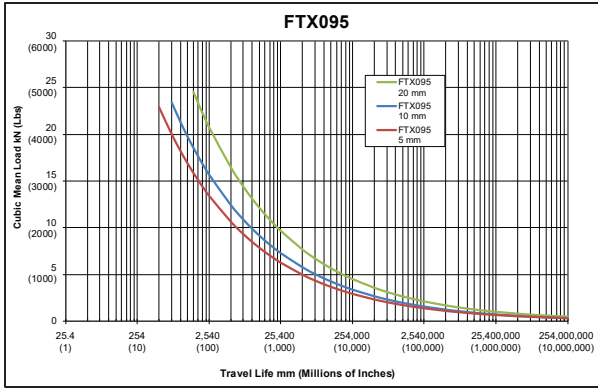

The L_{10} expected life of a roller screw linear actuator is expressed as the linear travel distance that 90% of properly maintained roller screws manufactured are expected to meet or exceed. This is not a guarantee and these charts should be used for estimation purposes only.

The underlying formula that defines this value is:
Travel life in millions of inches, where:

$$L_{10} = \left(\frac{C_a}{F_{cml}} \right)^3 \times \ell$$

C_a = Dynamic load rating (lbf)
 F_{cml} = Cubic mean applied load (lbf)
 ℓ = Roller screw lead (inches)

Service Life Estimate Assumptions:

- Sufficient quality and quantity of lubrication is maintained throughout service life
- Bearing and screw temperature between 20° C and 40° C
- No mechanical hard stops (external or internal) or impact loads
- No external side loads
- Does not apply to short stroke, high frequency applications such as fatigue testing or short stroke, high force applications such as pressing.

Dimensions

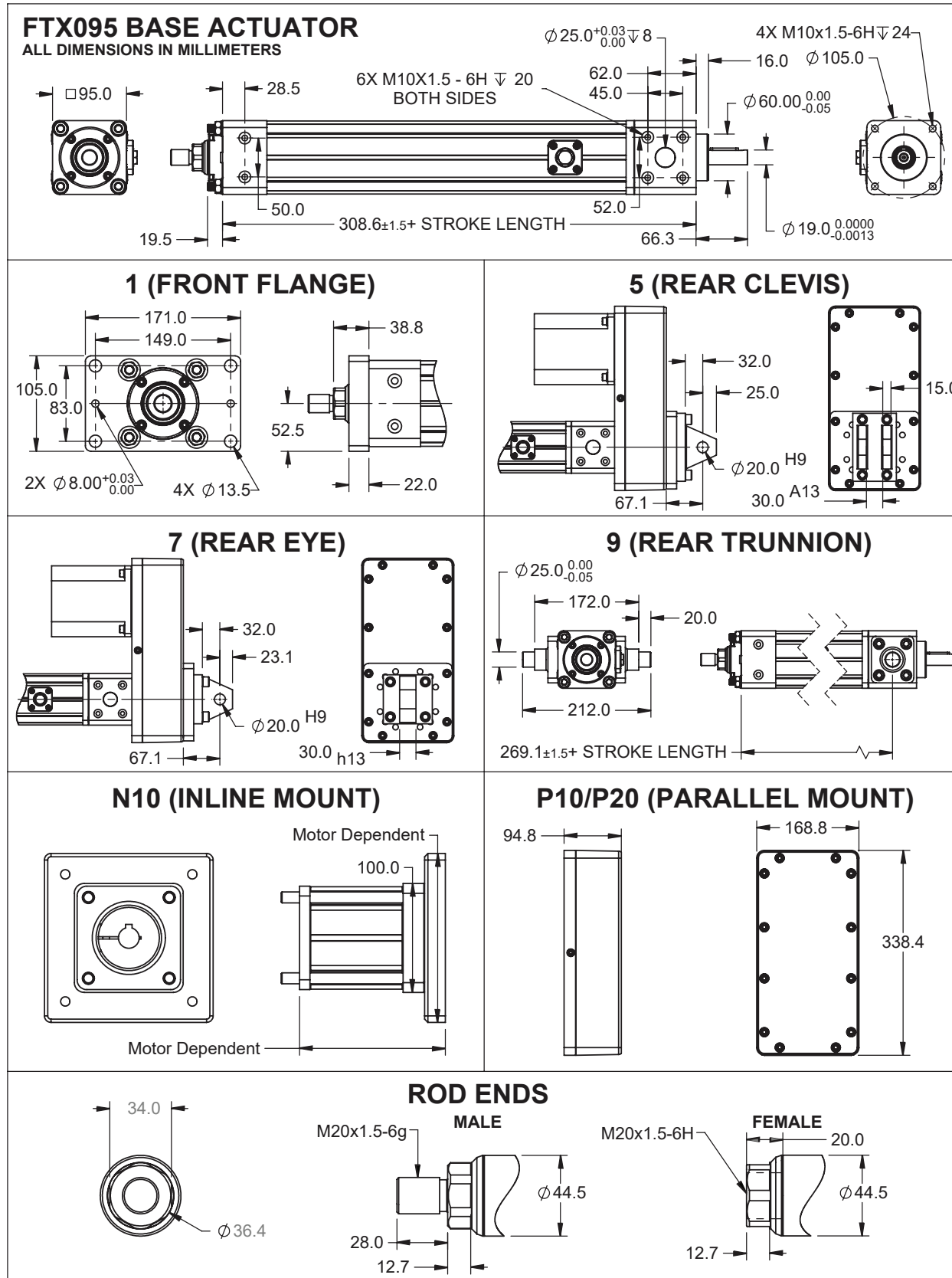

Pre-sale drawings and models are representative and are subject to change.

FTX125 BASE ACTUATOR

ALL DIMENSIONS IN MILLIMETERS

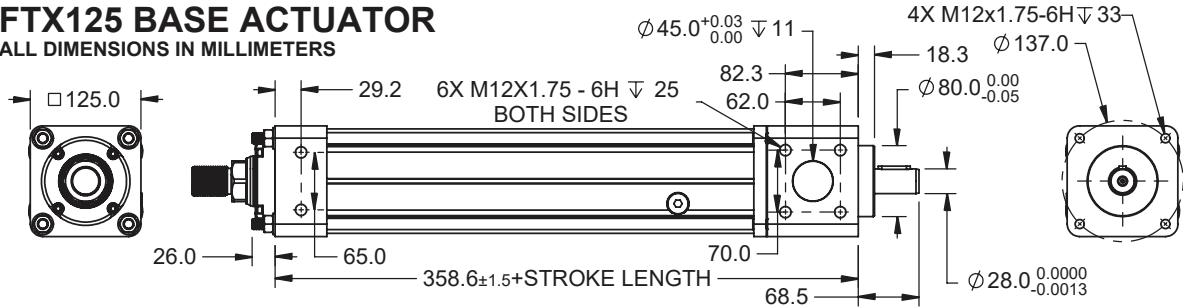

1 (FRONT FLANGE)

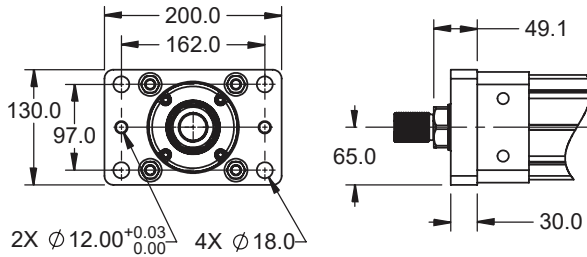

5 (REAR CLEVIS)

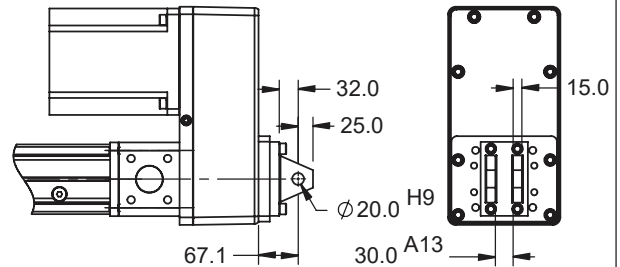

7 (REAR EYE)

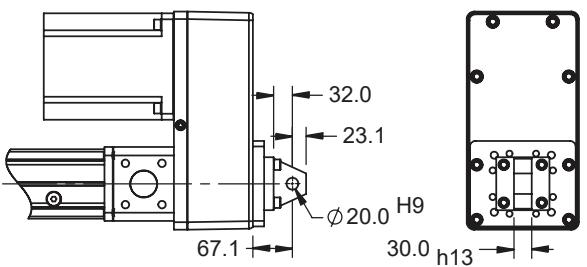

9 (REAR TRUNNION)

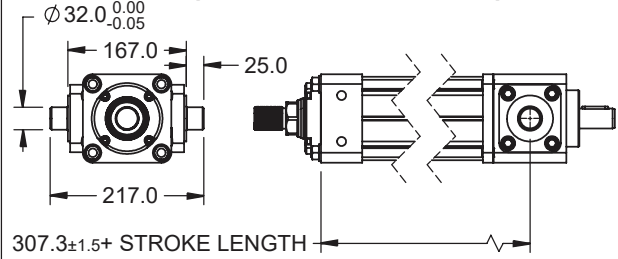

P10 (PARALLEL MOUNT)

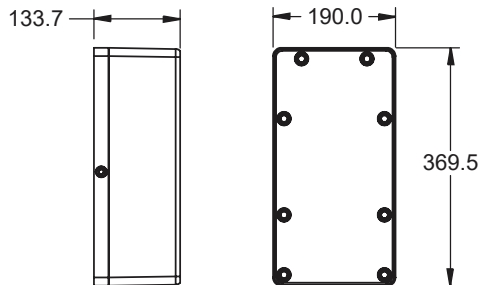

P20 (PARALLEL MOUNT)

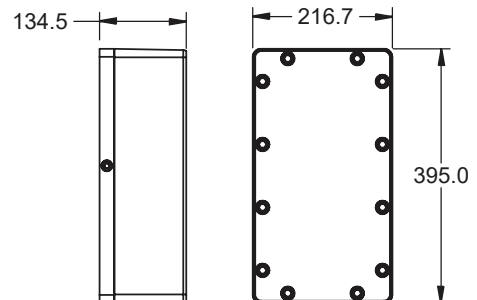

N10 (INLINE MOUNT)

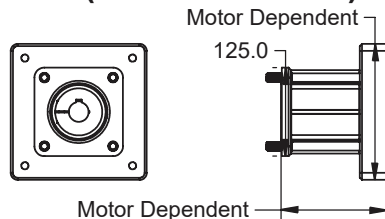

ROD ENDS

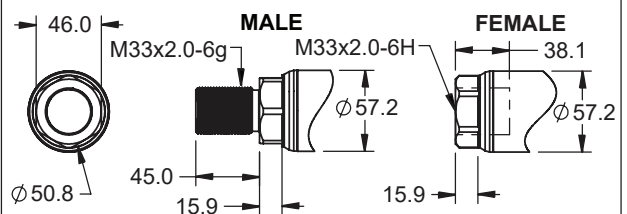

Pre-sale drawings and models are representative and are subject to change.

FTX160 BASE ACTUATOR

ALL DIMENSIONS IN MILLIMETERS

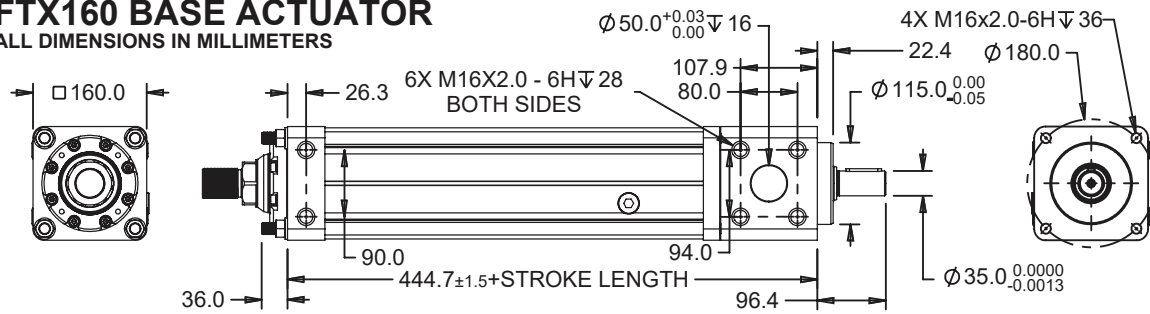

1 (FRONT FLANGE)

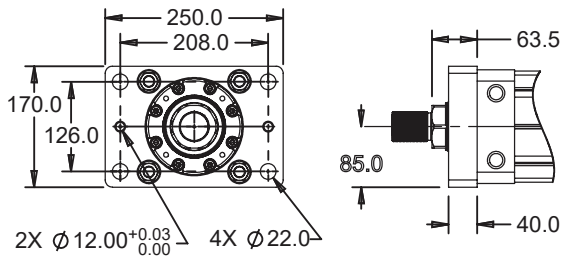

5 (REAR CLEVIS)

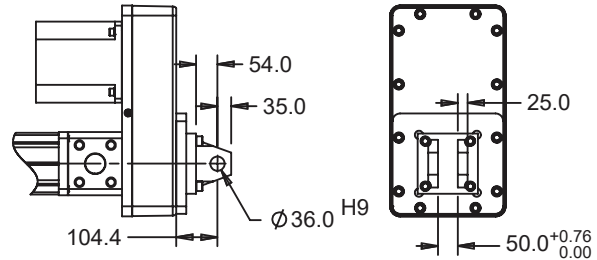

7 (REAR EYE)

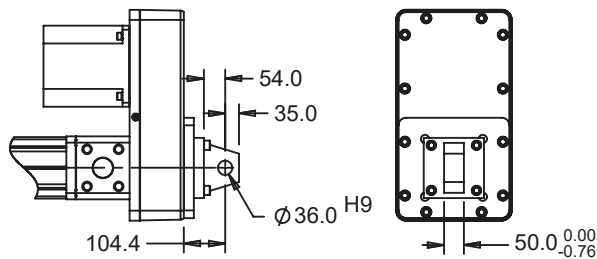

9 (REAR TRUNNION)

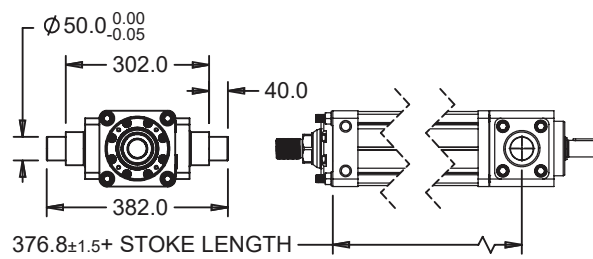

N10 (INLINE MOUNT)

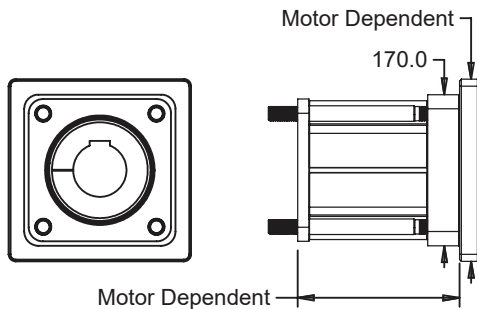

P10/P20 (PARALLEL MOUNT)

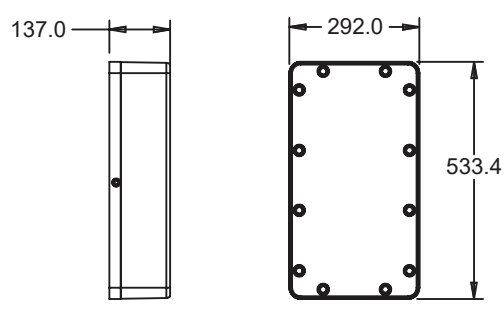

ROD ENDS

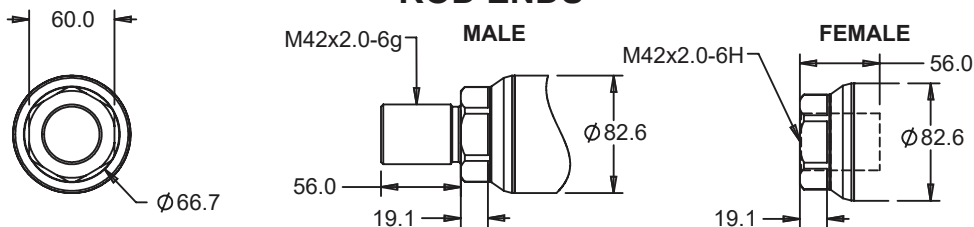

Pre-sale drawings and models are representative and are subject to change.

FTX215 BASE ACTUATOR

ALL DIMENSIONS IN MILLIMETERS

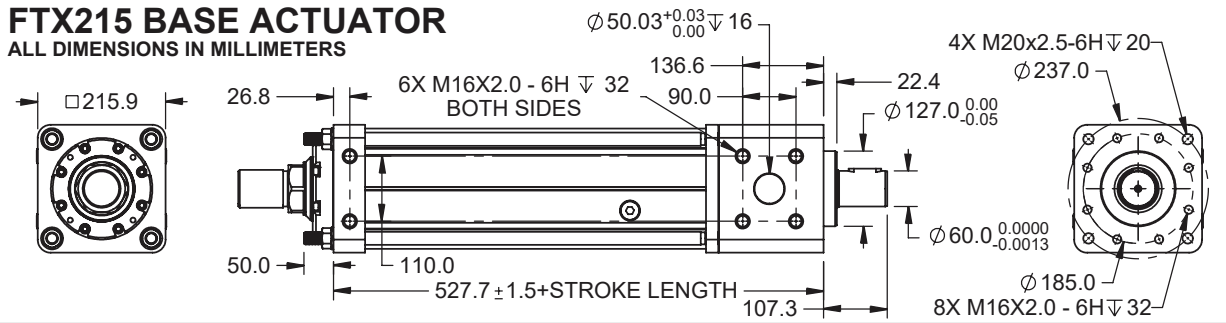

1 (FRONT FLANGE)

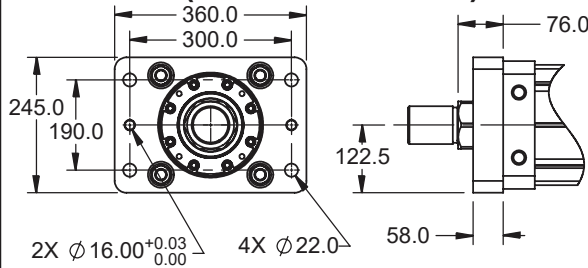

5 (REAR CLEVIS)

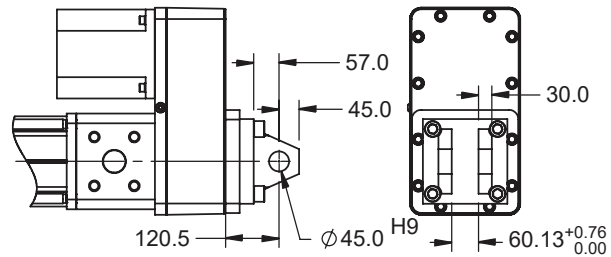

7 (REAR EYE)

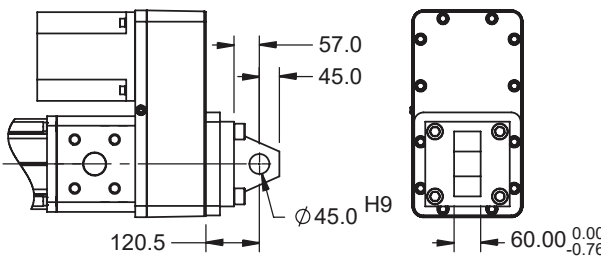

9 (REAR TRUNNION)

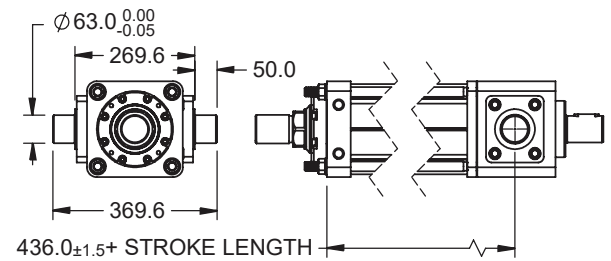

P10/P20 (PARALLEL MOUNT)

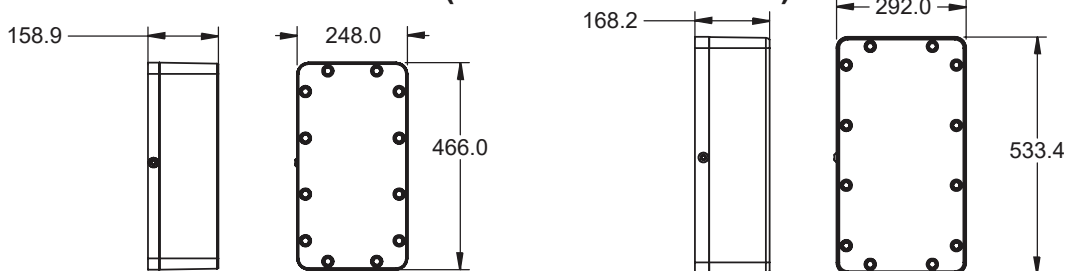

NOTE: 248mm WIDE HOUSING USED FOR MOTORS WITH 215mm MOUNTING B.C AND SMALLER, 1:1
292mm WIDE HOUSING USED FOR ALL 2:1 DRIVE MOTORS

N10 (INLINE MOUNT)

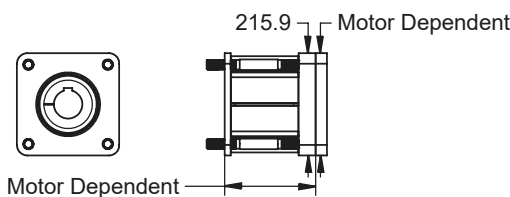

ROD ENDS

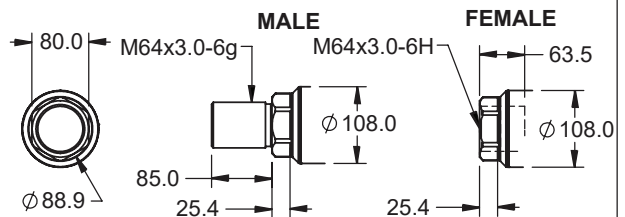

Pre-sale drawings and models are representative and are subject to change.

Rod Eye, Spherical

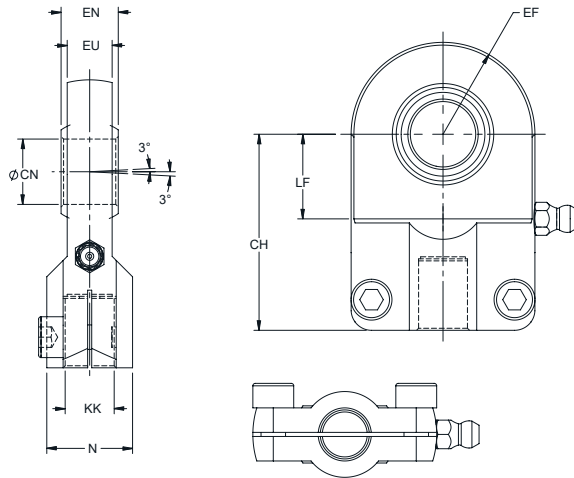

		FTX095	FTX125	FTX160	FTX215
AV	mm	29.0	46.0	55.0	86.0
	in	1.14	1.81	2.17	3.39
CH	mm	85.0	130.0	150.0	240.0
	in	3.35	5.12	5.91	9.45
CN	mm	30.0	50.0	60.0	100.0
	in	1.18	1.97	2.36	3.94
EF (max)	mm	41.0	61.0	80.0	120.0
	in	1.61	2.40	3.15	4.72
EN	mm	22.0	35.0	44.0	70.0
	in	0.87	1.38	1.73	2.76
EU (max)	mm	20.0	31.0	39.0	57.0
	in	0.79	1.22	1.54	2.24
KK		M20X1.5 6H	M33X2.0 6H	M42X2.0 6H	M64X3.0 6H
LF (min)	mm	35.0	58.0	68.0	116.0
	in	1.38	2.28	2.68	4.57
N (max)	mm	37.0	57.0	69.0	110.0
	in	1.46	2.24	2.72	4.33

Case Dimensions

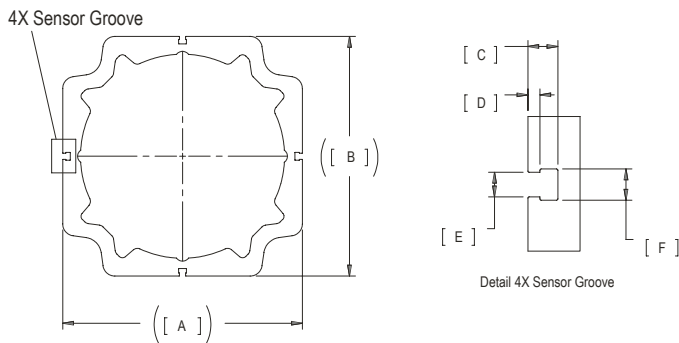

		FTX095	FTX125	FTX160	FTX215
A	mm	94	118	156	203
	in	3.7	4.6	6.1	8.0
B	mm	94	118	156	203
	in	3.7	4.6	6.1	8.0
C	mm	4.9	5.6	5.5	6.4
	in	0.19	0.22	0.22	0.25
D	mm	1.1	1.8	1.7	2.5
	in	0.4	0.07	0.07	0.10
E	mm	5.2	5.2	5.3	5.2
	in	0.21	0.21	0.21	0.21
F	mm	6.6	6.6	6.6	6.6
	in	0.26	0.26	0.26	0.26

Rod Clevis

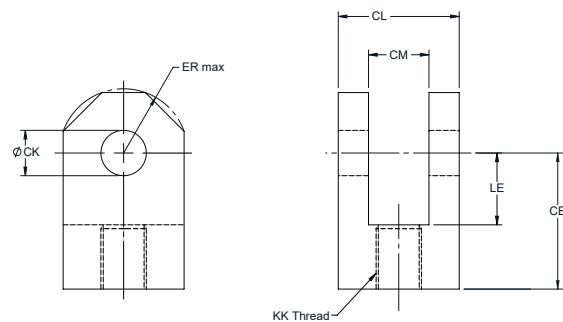

		FTX095	FTX125	FTX160	FTX215
CE	mm	60.0	99.0	113.0	168.0
	in	2.36	3.90	4.45	6.61
Ø CK	mm	20.0 h9	36.0 h9	45.0 h9	70.0 h9
	in	0.79	1.42	1.77	2.76
CL	mm	62.0	103.0	123.0	163.0
	in	2.44	4.06	4.84	6.42
CM	mm	30.0	50.0	60.0	80.0
	in	1.18	1.97	2.36	3.15
Ø ER (max)	mm	29.0	50.0	53.0	78.0
	in	1.14	1.97	2.09	3.07
LE (min)	mm	32.0	54.0	57.0	83.0
	in	1.26	2.13	2.24	3.27
KK		M20X1.5 6H	M33X2.0 6H	M42X2.0 6H	M64X3.0 6H

Standard Motor/Gearbox Mount Codes for the FTX

FTX095 Motor / Gearbox Mounts													
None		Inline				Parallel 1:1				Parallel 2:1			
		Motor Flange Code		Dimension in mm		Motor Flange Code		Dimension in mm		Motor Flange Code		Dimension in mm	
Motor Flange Code		Motor Flange Code		Bolt Circle	Pilot Diam.	Motor Flange Code		Bolt Circle	Pilot Diam.	Motor Flange Code		Bolt Circle	Pilot Diam.
NMT-	00	N10-	02	68	60	P10-	02	68	60	P20-	02	68	60
		N10-	04	75	60	P10-	04	75	60	P20-	04	75	60
		N10-	05	85	70	P10-	05	85	70	P20-	05	85	70
		N10-	10	100	80	P10-	10	100	80	P20-	10	100	80
		N10-	11	115	95	P10-	11	115	95	P20-	11	115	95
		N10-	12	130	110	P10-	12	130	110	P20-	12	130	110
		N10-	13	130	95	P10-	13	130	95	P20-	13	130	95
		N10-	14	145	110	P10-	14	145	110	P20-	14	145	110
		N10-	19	165	130	P10-	19	165	130	P20-	19	165	130
Motor Shaft Code		Motor Shaft Code		Shaft Diam.	Key Width*	Motor Shaft Code		Shaft Diam.	Key Width*	Motor Shaft Code		Shaft Diam.	Key Width*
00		AA		24	8	AA		24	8	AA		24	8
		BA		22	6	BA		22	6	BA		22	6
		CA		22	8	CA		22	8	CA		22	8
		DA		20	6	DA		20	6	DA		20	6
		EA		19	6	EA		19	6	EA		19	6
		FA		16	5	FA		16	5	FA		16	5
		GA		14	5	GA		14	5	GA		14	5
		LA		28	8	LA		28	8	LA		28	8
		MA		32	10	MA		32	10				
Shaft Length		Shaft Length		Shaft Length		Shaft Length		Shaft Length		Shaft Length		Shaft Length	
000		030, 032, 040, 048, 050, 055, 058, 060, 063, 065, 070, 080		Pick closest shaft length within 2mm if your exact length is not listed		038-084		Allowable shaft length range in 1 mm increments		038-084		Allowable shaft length range in 1 mm increments	

*Key not required for operation

FTX125 Motor / Gearbox Mounts

None		Inline				Parallel 1:1				Parallel 2:1			
		Dimension in mm				Dimension in mm				Dimension in mm			
Motor Flange Code	Motor Flange Code	Bolt Circle	Pilot Diam.	Motor Flange Code	Bolt Circle	Pilot Diam.	Motor Flange Code	Bolt Circle	Pilot Diam.	Motor Flange Code	Bolt Circle	Pilot Diam.	
NMT-	00	N10-05	85	70	P10-05	85	70	P20-05	85	70			
		N10-10	100	80	P10-10	100	80	P20-10	100	80			
		N10-12	130	110	P10-12	130	110	P20-12	130	110			
		N10-14	145	110	P10-14	145	110	P20-14	145	110			
		N10-18	120	90	P10-18	120	90	P20-19	165	130			
		N10-19	165	130	P10-19	165	130	P20-20	200	114.3			
		N10-20	200	114.3	P10-20	200	114.3	P20-21	215	130			
		N10-21	215	130	P10-21	215	130	P20-23	215	180			
		N10-23	215	180	P10-23	215	180						

Motor Shaft	Motor Shaft Code	Shaft Diam.	Key Width*	Motor Shaft code	Shaft Diam.	Key Width*	Motor Shaft Code	Shaft Diam.	Key Width*
00	AA	24	8	AA	24	8	AA	24	8
	AB	28	10	AB	28	10	AB	28	10
	BA	22	6	BA	22	6	BA	22	6
	DA	20	6	DA	20	6	DA	20	6
	EA	19	6	EA	19	6	EA	19	6
	LA	28	8	LA	28	8	LA	28	8
	MA	32	10	MA	32	10	MA	32	10
	NA	35	10	NA	35	10	NA	35	10
	PA	38	10	PA	38	10	YA	24	10
	RA	42	12	RA	42	12			
	SA	42	10	SA	42	10			
	YA	24	10	YA	24	10			

Shaft Length	Shaft Length	Shaft Length	Shaft Length
000	040, 046, 049, 050, 055, 058, 060, 063, 065, 068, 072, 080, 082, 088, 097, 100, 102, 105, 112, 113	Pick closest shaft length within 2mm if your exact length is not listed	048-099
			Allowable shaft length range in 1 mm increments
			048-099
			Allowable shaft length range in 1 mm increments

*Key not required for operation

FTX160 Motor / Gearbox Mounts													
None		Inline				Parallel 1:1				Parallel 2:1			
		Motor Flange Code		Dimension in mm		Motor Flange Code		Dimension in mm		Motor Flange Code		Dimension in mm	
Motor Flange Code	Motor Flange Code	Bolt Circle	Pilot Diam.	Motor Flange Code	Bolt Circle	Pilot Diam.	Motor Flange Code	Bolt Circle	Pilot Diam.	Motor Flange Code	Bolt Circle	Pilot Diam.	Motor Flange Code
NMT-	00	N10-	10	100	80	P10-	10	100	80	P20-	10	100	80
		N10-	12	130	110	P10-	12	130	110	P20-	12	130	110
		N10-	18	120	90	P10-	18	120	90	P20-	18	120	90
		N10-	19	165	130	P10-	19	165	130	P20-	19	165	130
		N10-	20	200	114.3	P10-	20	200	114.3	P20-	20	200	114.3
		N10-	21	215	130	P10-	21	215	130	P20-	21	215	130
		N10-	22	215	160	P10-	22	215	160	P20-	23	215	180
		N10-	23	215	180	P10-	23	215	180	P20-	24	235	200
		N10-	24	235	200	P10-	24	235	200	P20-	25	265	230
		N10-	25	265	230	P10-	25	265	230				
Motor Shaft Code	Motor Shaft Code	Shaft Diam.	Key Width*	Motor Shaft Code	Shaft Diam.	Key Width*	Motor Shaft Code	Shaft Diam.	Key Width*	Motor Shaft Code	Shaft Diam.	Key Width*	Motor Shaft Code
00	AA	24	8	AA	24	8	AA	24	8	AA	24	8	AA
	BA	22	6	BA	22	6	BA	22	6	BA	22	6	BA
	LA	28	8	LA	28	8	LA	28	8	LA	28	8	LA
	MA	32	10	MA	32	10	MA	32	10	MA	32	10	MA
	NA	35	10	NA	35	10	NA	35	10	NA	35	10	NA
	PA	38	10	PA	38	10	PA	38	10	PA	38	10	PA
	QA	40	12	QA	40	12	QA	40	12	QA	40	12	QA
	RA	42	12	RA	42	12	RA	42	12	RA	42	12	RA
	SA	42	10	SA	42	10	SA	42	10	SA	42	10	SA
	UA	55	16	UA	55	16	UA	55	16	ZA	25	8	ZA
	ZA	25	8	ZA	25	8							
Shaft Length	Shaft Length			Shaft Length			Shaft Length			Shaft Length			Shaft Length
000	040, 048, 050, 055, 058, 060, 070, 072, 080, 082, 085, 088, 097, 100, 105, 110, 112, 113, 116	Pick closest shaft length within 2mm if your exact length is not listed		060-124	Allowable shaft length range in 1 mm increments		060-124	Allowable shaft length range in 1 mm increments		060-124	Allowable shaft length range in 1 mm increments		060-124

*Key not required for operation

FTX215 Motor / Gearbox Mounts													
None		Inline				Parallel 1:1				Parallel 2:1			
		Motor Flange Code		Dimension in mm		Motor Flange Code		Dimension in mm		Motor Flange Code		Dimension in mm	
Motor Flange Code	Motor Flange Code	Bolt Circle	Pilot Diam.	Motor Flange Code	Bolt Circle	Pilot Diam.	Motor Flange Code	Bolt Circle	Pilot Diam.	Motor Flange Code	Bolt Circle	Pilot Diam.	Motor Flange Code
NMT- 00	N10- 19	165	130	P10- 19	165	130	P20- 19	165	130				
	N10- 22	215	160	P10- 22	215	160	P20- 23	215	180				
	N10- 23	215	180	P10- 23	215	180	P20- 25	265	230				
	N10- 24	235	200	P10- 24	235	200	P20- 26	300	250				
	N10- 25	265	230	P10- 25	265	230							
	N10- 26	300	250	P10- 26	300	250							
Motor Shaft Code	Motor Shaft Code	Shaft Diam.	Key Width*	Motor Shaft Code	Shaft Diam.	Key Width*	Motor Shaft Code	Shaft Diam.	Key Width*	Motor Shaft Code	Shaft Diam.	Key Width*	Motor Shaft Code
00	PA	38	10	PA	38	10	PA	38	10				
	QA	40	12	QA	40	12	QA	40	12				
	RA	42	12	RA	42	12	RA	42	12				
	TA	48	14	TA	48	14	TA	48	14				
	UA	55	16	UA	55	16							
	VA	60	18	VA	60	18							
	WA	65	18	WA	65	18							
Shaft Length	Shaft Length			Shaft Length			Shaft Length			Shaft Length			Shaft Length
000	080, 082, 085, 097, 100, 102, 105, 110, 112, 116, 140	Pick closest shaft length within 2mm if your exact length is not listed		070-155	Allowable shaft length range in 1 mm increments		070-155	Allowable shaft length range in 1 mm increments		070-155	Allowable shaft length range in 1 mm increments		070-155

*Key not required for operation

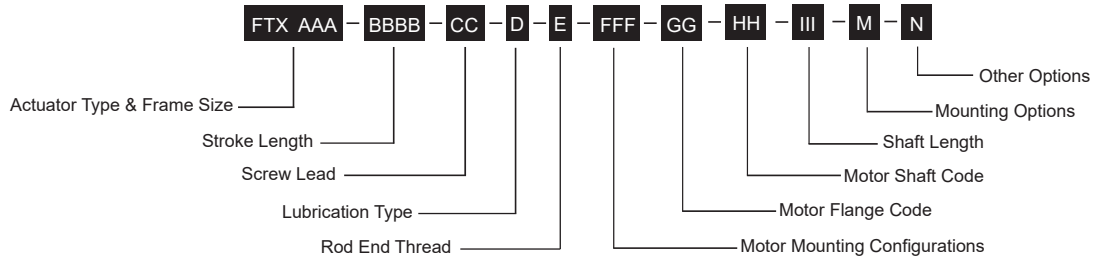

AAA = Frame Size

- 095 = 95 mm
- 125 = 125 mm
- 160 = 160 mm
- 215 = 215 mm

BBBB = Stroke Length

- 0150 = 150 mm
- 0300 = 300 mm
- 0600 = 600 mm
- 0900 = 900 mm (FTX095, FTX125, FTX160)

CC = Screw Lead

- 05 = 5 mm (FTX095, FTX125)
- 06 = 6 mm (FTX160, FTX215)
- 10 = 10 mm (FTX095, FTX125)
- 12 = 12 mm (FTX160, FTX215)
- 20 = 20 mm (FTX095)
- 30 = 30 mm (FTX160, FTX215)

D = Lubrication Type

- 1 = Grease
- 2 = Oil
- 3 = Low Temperature Grease (to -40° C)

E = Rod End Thread

- A = Male, Metric
- B = Female, Metric
- M = Male, English³
- F = Female, English³

FFF = Motor Mounting Configurations¹

- NMT = None, base unit only
- N10 = Inline, includes shaft coupling
- P10 = Parallel, 1:1 belt reduction
- P20 = Parallel, 2:1 belt reduction

GG = Motor/Gearbox Flange Code

See standard motor/gearbox mounting code dimension sheet

HH = Motor Shaft Code

See standard motor/gearbox mounting code dimension sheet

III = Shaft Length

See standard motor/gearbox mounting code dimension sheet

M = Mounting Options

- N = None
- 1 = Front Flange, Metric
- 5 = Rear Clevis, Metric²
- 7 = Rear Eye, Metric²
- 9 = Rear Trunion, Metric
- F = Front Flange, English³
- C = Rear Clevis, English³ (Not available on FTX215)
- G = Rear Clevis, Metric³ (Not available on FTX125 or FTX215)

N = Other Options

- N = None
- L = Limit Switches*

*Ordered Separately



For options or specials not listed above, please contact Exlar

NOTES:
 1. Always discuss your motor selection with your local sales representative.
 2. Not available with inline or NMT motor mount, contact your local sales representative.
 3. Available option. May add lead time

FTX Series Accessories

Exlar Part Number	Switches Type
43403	Normally Open PNP Limit Switch (10-30 VDC, 1m. 3 wire embedded cable)
43404	Normally Closed PNP Limit Switch (10-30 VDC, 1m. 3 wire embedded cable)
67634	Normally Open NPN Limit Switch (10-30 VDC, 1m. 3 wire embedded cable)
67635	Normally Closed NPN Limit Switch (10-30 VDC, 1m. 3 wire embedded cable)

1. **OFFER AND ACCEPTANCE:** These terms and conditions constitute Seller's offer to Buyer and acceptance by Buyer and any resulting sale is expressly limited to and conditioned upon Seller's terms and conditions as set forth below. If Buyer objects to any of Seller's terms and conditions, such objections must be expressly stated and brought to the attention of Seller in a written document which is separate from any purchase order or other printed form of Buyer. Such objections, or the incorporation of any additional or different terms or conditions by Buyer into a resulting order shall constitute non-acceptance of these Terms and Conditions, releasing Seller from any obligation or liability hereunder and a proposal for different terms and conditions which shall be objected to by Seller unless expressly accepted in writing by an authorized representative of Seller. Acknowledgment copy, if any, shall not constitute acceptance by Seller of any additional or different terms or conditions, nor shall Seller's commencement of effort, in itself, be construed as acceptance of an order containing additional or different terms and conditions.

2. **PRICES:** Published prices and discount schedules are subject to change without notice. They are prepared for the purpose of furnishing general information and are not quotations or offers to sell on the part of the company.

3. **TRADE TERMS:** Shipment terms are FCA, shipping point (Exlar, Chanhassen, MN). FCA (Free Carrier) per Incoterms 2010 means the Seller delivers the goods, cleared for export into the custody of the first carrier named by the buyer at the named place, above. This term is suitable for all modes of transport, including carriage by air, rail, road, and containerized/multi-modal transport. Title of the merchandise transfers from Exlar Corporation to the Buyer when it is received from Exlar by the carrier. Where allowable, Exlar will arrange the transportation via the carrier specified by the Buyer. The Buyer is responsible for all costs associated with the shipment.

4. **PAYMENT TERMS:** Subject to approval of Buyer's credit, the full net amount of each invoice is due and payable in cash within thirty (30) days of shipment. No payment discounts are offered, and minor inadvertent administrative errors contained in an invoice are subject to correction and shall not constitute reason for untimely payment. If, in the judgment of the Seller, the financial credit of Buyer at any time does not justify continuance of production or shipment of any product(s) on the payment terms herein specified, Seller may require full or partial payment prior to completion of production or shipment, or may terminate any order, or any part thereof, then outstanding. Custom products and blanket orders are subject to payment terms: 30% due at time of order, 70% due net 30 days from shipment.

5. **MINIMUM BILLING:** Minimum billing will be \$50.00.

6. **DELAYS:** Exlar shall not be liable for any defaults, damages or delays in fulfilling any order caused by conditions beyond Seller's control, including but not limited to acts of God, strike, lockout, boycott, or other labor troubles, war, riot, flood, government regulations, or delays from Seller's subcontractors or suppliers in furnishing materials or supplies due to one or more of the foregoing clauses.

7. **CANCELLATIONS:** All cancelled orders for standard products are subject to order cancellation charges. The minimum cancellation charge will be 20% of the order total. Standard products, if unused may be returned in accordance with the current return policy. All returns are subject to prior approval by Exlar, and return charges may apply. No return credit for any product will be issued or authorized prior to evaluation of the product by Exlar. Custom product is not returnable. Orders for custom product are not cancelable.

8. **QUANTITY PRICING AND BLANKET ORDER PRICING TERMS:** Blanket order quantity pricing requires a complete delivery schedule for the volume being ordered, with all units scheduled to deliver within a 15 month period from the placement of the purchase order to the final scheduled shipment. Any requests to change the delivery schedule of a blanket order must be received in writing 60 days prior to the requested change. Failure to take delivery of the entire ordered volume will result in back charges equal to the difference in quantity price between the volume ordered and the volume received times the number of units received. A cancellation charge in accordance with the cancellation policy (item 7) will apply to any reduction in delivered volume from the original ordered quantity.

For orders receiving quantity discounts, but not as scheduled blanket orders, the same quantity pricing rules apply. Failure to take delivery of the entire quantity ordered will result in back charges equal to the difference in quantity price between the volume ordered and the volume received times the number of units received. Cancellation charges in accordance with the cancellation policy (item 7) will apply to any reduction in delivered volume from the original ordered quantity. For either blanket orders or quantity orders, in addition to any applicable cancellation charges, the customer is responsible for the value of any additional inventory allocated specifically to their order. Charges for this inventory will be invoiced in addition to cancellation charges, along with any back charges for quantity variance.

9. **DESTINATION CONTROL STATEMENT:** Exlar products, technology or software are exported from the United States in accordance with the Export Administration Regulations (EAR) or International Traffic in Arms Regulations (ITAR) as applicable. Diversion, transfer, transshipment or disposal contrary to U.S. law is prohibited.

10. **EXPORT CONTROL AND SHIPMENT REGULATIONS:** Purchaser agrees at all times to comply with all United States laws and regulations as well as International Trade Laws, as they may exist from time to time, regarding export licenses or the control or regulation of exportation or re-exportation of products or technical data sold or supplied to Distributor. Seller may terminate or suspend this order, without remedy, should the Purchaser become an entity identified on any US export denial listing. Products ordered may require authorization and/or validated export license from a U.S. government agency. Seller may terminate or suspend this order, without remedy, should a government agency approval be denied.

11. **GOVERNING LAW AND VENUE:** This order shall be governed by, and construed in accordance with the laws of the State of Minnesota, U.S.A. All disputes shall be resolved by a court of competent jurisdiction in the trial courts of Carver County, in the State of Minnesota.

12. **ATTORNEY FEES:** Reasonable attorney's fees and other expenses of litigation must be awarded to the prevailing party in an action in which a remedy is sought under this order.

13. **NON-WAIVER:** The failure by the Seller to require performance of any provision shall not affect the Seller's right to require performance at any time thereafter, nor shall a waiver of any breach or default of this Order constitute a waiver of any subsequent breach or default or a waiver of the provision itself.

14. **MERGER AND INTEGRATION:** These Terms and Conditions contain the entire agreement of the parties with respect to the subject matter of this order, and supersede all prior negotiations, agreements and understandings with respect thereto. Purchase orders may only be amended by a written document duly executed by buyer and seller.

15. **INDEMNITY:** Buyer agrees to indemnify, defend and hold harmless Exlar from any claims, loss or damages arising out of or related to Seller's compliance with Buyer's designs, specifications or instructions in the furnishing of products to Buyer, whether based on infringement of patents, copyrights, trademark or other right of others, breach of warranty, negligence, or strict liability or other tort.

WARRANTY AND LIMITATION OF LIABILITY: Products are warranted for two years from date of manufacture as determined by the serial number on the product label. Labels are generated and applied to the product at the time of shipment. The first and second digits are the year and the third and fourth digits represent the manufacturing week. Product repairs are warranted for 90 days from the date of the repair. The date of repair is recorded within the Exlar database and tracked by individual product serial number.

Exlar Corporation warrants its product(s) to the original purchaser and in the case of original equipment manufacturers, to their original customer to be free from defects in material and workmanship and to be made only in accordance with Exlar standard published catalog specifications for the product(s) as published at the time of purchase. Warranty or performance to any other specifications is not covered by this warranty unless otherwise agreed to in writing by Exlar and documented as part of any and all contracts, including but not limited to purchase orders, sales orders, order confirmations, purchase contracts and purchase agreements. In no event shall Exlar be liable or have any responsibility under such warranty if the product(s) has been improperly stored, installed, used or maintained, or if Buyer has permitted any unauthorized modifications, adjustments and/or repairs to such product(s). Seller's obligation hereunder is limited solely to repairing or replacing (at its option), at the factory any product(s), or parts thereof, which prove to Seller's satisfaction to be defective as a result of defective materials, or workmanship and within the period of time, in accordance with the Seller's stated product warranty (see Terms and Conditions above), provided, however, that written notice of claimed defects shall have been given to Exlar within thirty (30) days from the date of any such defect is first discovered. The product(s) claimed to be defective must be returned to Exlar, transportation prepaid by Buyer, with written specification of the claimed defect. Evidence acceptable to Exlar must be furnished that the claimed defects were not caused by misuse, abuse, or neglect by anyone other than Exlar.

Components such as seals, wipers, bearings, brakes, bushings, gears, splines, and roller screw parts are considered wear parts and must be inspected and serviced on a regular basis. Any damage caused by failure to properly lubricate Exlar products and/or to replace wear parts at appropriate times, is not covered by this warranty. Any damage due to excessive loading is not covered by this warranty.

The use of products or components under load such that they reach the end of their expected life is a normal characteristic of the application of mechanical products. Reaching the end of a product's expected life does not indicate any defect in material or workmanship and is not covered by this warranty.

Costs for shipment of units returned to the factory for warranty repairs are the responsibility of the owner of the product. Exlar will return ship all warranty repairs or replacements via UPS Ground at no cost to the customer.

For international customers, Exlar will return ship warranty repairs or replacements via UPS Expedited Service and cover the associated shipping costs. Any VAT or local country taxes are the responsibility of the owner of the product.

The foregoing warranty is in lieu of all other warranties (except as Title), whether expressed or implied, including without limitation, any warranty of merchantability, or of fitness for any particular purpose, other than as expressly set forth and to the extent specified herein, and is in lieu of all other obligations or liabilities on the part of Exlar.

Seller's maximum liability with respect to these terms and conditions and any resulting sale, arising from any cause whatsoever, including without limitation, breach of contract or negligence, shall not exceed the price specified of the product(s) giving rise to the claim, and in no event shall Exlar be liable under this warranty otherwise for special, incidental or consequential damages, whether similar or dissimilar, of any nature arising or resulting from the purchase, installation, removal, repair, operation, use or breakdown of the product(s) or any other cause whatsoever, including negligence.

The foregoing warranty shall also apply to products or parts which have been repaired or replaced pursuant to such warranty, and within the period of time, in accordance with Seller's stated warranty.

NO PERSON INCLUDING ANY AGENT OR REPRESENTATIVE OF EXLAR CORPORATION IS AUTHORIZED TO MAKE ANY REPRESENTATION OR WARRANTY ON BEHALF OF EXLAR CONCERNING ANY PRODUCTS MANUFACTURED BY EXLAR, EXCEPT TO REFER PURCHASERS TO THIS WARRANTY.

USA & CANADA

Exlar Automation
18400 West 77th Street
Chanhassen, MN 55317
Phone: 855-620-6200 (US & Canada)
Fax: 952-368-4877

EUROPE

Exlar Europe GmbH
Schleißheimer Str., 91a
Garching bei München D-85748
Germany
Phone: +49 6184 994730

ASIA

Exlar Asia Pacific
1007 Pine City Hotel
8 Dong An Road, Xuhui District
Shanghai 200032 China
Phone: +86 021-6495-7868

Distributed by:



www.exlar.com

Exlar® actuators are a brand of Curtiss-Wright, Actuation Division.